

ICC-ES Evaluation Report

ESR-5492

Issued May 2024

This report also contains:

Subject to renewal May 2025

- CBC Supplement
- FBC Supplement
- LABC Supplement

ICC-ES Evaluation Reports are not to be construed as representing aesthetics or any other attributes not specifically addressed, nor are they to be construed as an endorsement of the subject of the report or a recommendation for its use. There is no warranty by ICC Evaluation Service, LLC, express or implied, as to any finding or other matter in this report, or as to any product covered by the report.

Copyright © 2024 ICC Evaluation Service, LLC. All rights reserved.

<p>DIVISION: 03 00 00— CONCRETE</p> <p>Section: 03 16 00— Concrete Anchors</p> <p>DIVISION: 05 00 00— METALS</p> <p>Section: 05 05 19— Post-Installed Concrete Anchors</p>	<p>REPORT HOLDER:</p> <p>CELO BEFESTIGUNGSSYSTEME GmbH</p>	<p>EVALUATION SUBJECT:</p> <p>CELO BTS CONCRETE SCREW ANCHORS IN CRACKED AND UNCRAKED CONCRETE</p>	
----------------------------------------------------------------------------------------------------------------------------------------------------------------------------------------------------------------------------	----------------------------------------------------------------------------------	----------------------------------------------------------------------------------------------------------------------------------	-------------------------------------------------------------------------------------

1.0 EVALUATION SCOPE

Compliance with the following codes:

- 2021, 2018, 2015, and 2012 [International Building Code® \(IBC\)](#)
- 2021, 2018, 2015, and 2012 [International Residential Code® \(IRC\)](#)

For evaluation for compliance with codes adopted by [Los Angeles Department of Building and Safety \(LADBS\)](#), see [ESR-5492 LABC and LARC Supplement](#).

Property evaluated:

- Structural

2.0 USES

The CELO BTS concrete screw anchors are used as anchorage to resist static, wind and seismic (Seismic Design Categories A through F) tension and shear loads in cracked and uncracked normal weight and lightweight concrete having a specified compressive strength, f'_c , of 2,500 psi to 8,500 psi (17.2 MPa to 58.6 MPa).

The anchors comply with anchors as described in Section 1901.3 of the 2021 IBC. The anchors are an alternative to cast-in-place anchors described in Section 1901.3 of the 2021, 2018 and 2015 IBC and Section 1908 and 1909 of the 2012 IBC. The anchors may also be used where an engineered design is submitted in accordance with Section R301.1.3 of the IRC.

3.0 DESCRIPTION

3.1 CELO BTS Anchors:

CELO BTS concrete screw anchors are comprised of an anchor body with hex washer head or a hex coupler head style, in various lengths. Available diameters are 1/4-inch, 3/8-inch, 1/2-inch, 5/8-inch and 3/4-inch (6.4 mm, 9.5 mm, 12.7 mm, 15.9 mm and 19.1 mm). The anchor body and hex washer head or coupler head are manufactured from carbon steel, are heat treated, and have minimum 0.0002-inch (5 µm) zinc plating or minimum 0.0024-inch (60 µm) mechanical zinc plating. The typical CELO BTS anchor is illustrated in [Figure 1](#).

The hex washer head and hex coupler head diameter is larger than the diameter of the anchor and is formed with serrations on the underside. The anchor body is formed with threads running most of the length of the anchor body. The hex coupler head anchors are available in 1/4-inch nominal anchor body diameter with an internally threaded coupler head that accepts 1/4-20 or 3/8-16 (UNC coarse) threaded rod or bolt, and 3/8-inch nominal anchor body diameter with an internally threaded coupler head that accepts 3/8-16 or 1/2-13 (UNC coarse) threaded rod or bolt. The anchor is installed in a predrilled hole with a powered impact wrench (all diameters) or torque wrench (1/4-inch and 3/4-inch diameters only). The anchor threads cut into the concrete on the sides of the hole and interlock with the base material during the installation.

3.2 Threaded Steel Insert Elements for hex coupler head anchors:

Threaded steel insert elements must be threaded into the coupler head anchors to form a connection. The material properties of the steel inserts must comply national or international specifications (e.g., ASTM A36; ASTM A307, ASTM F1554, Grade 36; ASTM A307, SAE J429, Grade 2, ASTM A193, Grade B7), or equivalent.

3.3 Concrete:

Normal-weight and lightweight concrete must conform to Sections 1903 and 1905 of the IBC.

4.0 DESIGN AND INSTALLATION

4.1 Strength Design:

4.1.1 General: Design strength of anchors complying with the 2021 IBC, as well as Section R301.1.3 of the 2021 IRC must be determined in accordance with ACI 318-19 Chapter 17 and this report.

Design strength of anchors complying with the 2018 and 2015 IBC, as well as Section R301.1.3 of the 2018 and 2015 IRC must be determined in accordance with ACI 318-14 Chapter 17 and this report.

Design strength of anchors complying with the 2012 IBC, as well as Section R301.1.3 of the 2012 IRC, must be determined in accordance with ACI 318-11 Appendix D and this report.

Design parameters are based on the 2021 IBC (ACI 318-19), 2018 and 2015 IBC (ACI 318-14) and the 2012 IBC (ACI 318-11) unless noted otherwise in Section 4.1.1 through 4.1.12 of this report.

The strength design of anchors must comply with ACI 318-19 17.5.1.2, ACI 318-14 17.3.1 or ACI 318-11 D.4.1, as applicable, except as required in ACI 318-19 17.10, ACI 318-14 17.2.3 or ACI 318-11 D.3.3, as applicable. Strength reduction factors, ϕ , as given in ACI 318-19 17.5.3, ACI 318-14 17.3.3 or ACI 318-11 D.4.3, as applicable, and noted in [Tables 3](#) and [4](#) of this report, must be used for load combinations calculated in accordance with Section 1605.1 of the 2021 IBC or Section 1605.2.1 of the 2018, 2015 and 2012 IBC, Section 5.3 of ACI 318 (-19 and -14), and Section 9.2 of ACI 318-11, as applicable. Strength reduction factors, ϕ , as given in ACI 318-11 D.4.4 must be used for load combinations calculated in accordance with Appendix C of ACI 318-11. The value of f'_c used in the calculation must be limited to a maximum of 8,000 psi (55.2 MPa), in accordance with ACI 318-19 17.3.1, ACI 318-14 17.2.7 or ACI 318-11 D.3.7, as applicable.

4.1.2 Requirements for Static Steel Strength in Tension, N_{sa} : The nominal static steel strength of a single anchor in tension, N_{sa} , calculated in accordance with ACI 318-19 17.6.1.2, ACI 318-14 17.4.1.2 or ACI 318-11 D.5.1.2, as applicable, is given in [Tables 3](#) and [4](#) of this report. Strength reduction factors, ϕ , corresponding to brittle steel elements must be used.

4.1.3 Requirements for Static Concrete Breakout Strength in Tension, N_{cb} or N_{cbg} : The nominal concrete breakout strength of a single anchor or a group of anchors in tension, N_{cb} or N_{cbg} , respectively, must be calculated in accordance with ACI 318-19 17.6.2, ACI 318-14 17.4.2 or ACI 318-11 D.5.2, as applicable, with modifications as described in this section. The basic concrete breakout strength of a single anchor in tension in cracked concrete, N_b , must be calculated according to ACI 318-19 17.6.2.2, ACI 318-14 17.4.2.2 or ACI 318-11 D.5.2.2, as applicable, using the values of h_{ef} and k_{cr} as given in [Tables 3](#) and [4](#) of this report. The nominal concrete breakout strength in tension in regions where analysis indicates no cracking in accordance with ACI 318-19 17.6.2.5.1(a), ACI 318-14 17.4.2.6 or ACI 318-11 D.5.2.6, as applicable, must be calculated with the value of k_{uncr} as given in [Tables 3](#) and [4](#) of this report and with $\psi_{c,N} = 1.0$.

4.1.4 Requirements for Static Pullout Strength in Tension, N_{pn} : The nominal pullout strength of a single anchor or a group of anchors, in accordance with ACI 318-19 17.6.3.1 and 17.6.3.2.1, ACI 318-14 17.4.3.1 and 17.4.3.2 or ACI 318-11 D.5.3.1 and D.5.3.2, as applicable, in cracked and uncracked concrete, $N_{p,cr}$ and $N_{p,uncr}$, respectively, is given in [Tables 3](#) and [4](#). In lieu of ACI 318-19 17.6.3.3, ACI 318-14 17.4.3.6 or ACI 318-11 D.5.3.6, as applicable, $\Psi_{c,P} = 1.0$ for all design cases. The nominal pullout strength in cracked concrete may be adjusted by calculation according to Eq-1:

$$N_{pn,f'_c} = N_{p,cr} \left(\frac{f'_c}{2,500} \right)^n \quad (\text{lb, psi}) \quad (\text{Eq-1})$$

$$N_{pn,f'_c} = N_{p,cr} \left(\frac{f'_c}{17.2} \right)^n \quad (\text{N, MPa})$$

where f'_c is the specified concrete compressive strength and n is the factor defining the influence of concrete compressive strength on pullout strength. For the nominal 1/4-inch and 5/8-inch diameter anchors, n is 0.4. For all other cases, n is 0.5.

In regions where analysis indicates no cracking in accordance with ACI 318-19 17.6.3.3, ACI 318-14 17.4.3.6 or ACI 318-11 D.5.3.6, as applicable, the nominal pullout strength in tension of the anchors can be adjusted by calculation according to Eq-2:

$$N_{pn,f'_c} = N_{p,uncr} \left(\frac{f'_c}{2,500} \right)^{0.5} \quad (\text{lb, psi}) \quad (\text{Eq-2})$$

$$N_{pn,f'_c} = N_{p,uncr} \left(\frac{f'_c}{17.2} \right)^{0.5} \quad (\text{N,MPa})$$

where f'_c is the specified concrete compressive strength.

Where values for $N_{p,cr}$ or $N_{p,uncr}$ are not provided in [Tables 3](#) and [4](#) of this report, the pullout strength in tension need not be considered or evaluated.

4.1.5 Requirements for Static Steel Strength in Shear, V_{sa} : The nominal steel strength in shear, V_{sa} , of a single anchor in accordance with ACI 318-19 17.7.1.2, ACI 318-14 17.5.1.2 or ACI 318-11 D.6.1.2, as applicable, is given in [Tables 3](#) and [4](#) of this report and must be used in lieu of the values derived by calculation from ACI 318-19 Eq. 17.7.1.2b, ACI 318-14 Eq. 17.5.1.2b or ACI 318-11, Eq. D-29, as applicable. Strength reduction factors, ϕ , corresponding to brittle steel elements must be used.

4.1.6 Requirements for Static Concrete Breakout Strength in Shear, V_{cb} or V_{cbg} : The nominal concrete breakout strength of a single anchor or group of anchors in shear, V_{cb} or V_{cbg} , respectively, must be calculated in accordance with ACI 318-19 17.7.2, ACI 318-14 17.5.2 or ACI 318-11 D.6.2, as applicable, with modifications as described in this section. The basic concrete breakout strength of a single anchor in shear, V_b , must be calculated in accordance with ACI 318-19 17.7.2.2.1, ACI 318-14 17.5.2.2 or ACI 318-11 D.6.2.2, as applicable, using the value of ℓ_e and d_a given in [Tables 3](#) and [4](#) of this report.

4.1.7 Requirements for Static Concrete Pryout Strength in Shear, V_{cp} or V_{cpg} : The nominal concrete pryout strength of a single anchor or group of anchors, V_{cp} or V_{cpg} , respectively, must be calculated in accordance with ACI 318-19 17.7.3, ACI 318-14 17.5.3 or ACI 318-11 D.6.3, as applicable, using the value of k_{cp} provided in [Tables 3](#) and [4](#), and the value of N_{cb} or N_{cbg} as calculated in Section 4.1.3 of this report.

4.1.8 Requirements for Seismic Design:

4.1.8.1 General: For load combinations including seismic loads, the design must be performed in accordance with ACI 318-19 17.10, ACI 318-14 17.2.3 or ACI 318-11 D.3.3, as applicable. Modifications to ACI 318-19 17.10, ACI 318-14 17.2.3 shall be applied under 2021, 2018 and 2015 IBC Section 1905.1.8. For the 2012 IBC, Section 1905.1.9 shall be omitted.

The nominal steel strength and nominal concrete breakout strength for anchors in tension, and the nominal concrete breakout strength and pryout strength for anchors in shear, must be calculated according to ACI 318-19 17.6 and 17.7, ACI 318-14 17.4 and 17.5 or ACI 318-11 D.5 and D.6, respectively, as applicable, taking into account the corresponding values in [Tables 3](#) and [4](#) of this report.

The anchors comply with ACI 318 (-19 or -14) 2.3 or ACI 318-11 D.1, as applicable, as brittle steel elements and must be designed in accordance with ACI 318-19 17.10.4, 17.10.5, 17.10.6, and 17.10.7; ACI 318-14 17.2.3.4, 17.2.3.5, 17.2.3.6, and 17.2.3.7; or ACI 318-11 D.3.3.4, D.3.3.5, D.3.3.6, and D.3.3.7, as applicable.

The anchors may be installed in regions designated as IBC Seismic Design Categories A through F.

4.1.8.2 Seismic Tension: The nominal steel strength and nominal concrete breakout strength for anchors in tension must be calculated according to ACI 318-19 17.6.1 and 17.6.2, ACI 318-14 17.4.1 and 17.4.2, or ACI 318-11 D.5.1 and D.5.2, respectively, as applicable, as described in Sections 4.1.2 and 4.1.3 of this report. In accordance with ACI 318-19 17.6.3.2.1, ACI 318-14 17.4.3.2 or ACI 318-11 D.5.3.2, as applicable, the appropriate value for nominal pullout strength in tension for seismic loads, $N_{p,eq}$ described in [Tables 3](#) and [4](#) of this report, must be used in lieu of N_p . $N_{p,eq}$ may be adjusted by calculations for concrete compressive strength in accordance with Eq-1 of this report.

Where values for $N_{p,eq}$ are not provided in [Tables 3](#) and [4](#), the pullout strength in tension for seismic forces need not be evaluated.

4.1.8.3 Seismic Shear: The nominal concrete breakout strength and pryout strength for anchors in shear must be calculated according to ACI 318-19 17.7.2 and 17.7.3, ACI 318-14 17.5.2 or 17.5.3, or ACI 318-11 D.6.2 and D.6.3, respectively, as applicable, as described in Sections 4.1.6 and 4.1.7 of this report. In accordance with ACI 318-19 17.7.1.2, ACI 318-14 17.5.1.2 or ACI 318-11 D.6.1.2, as applicable, the appropriate value for nominal steel strength in shear for seismic loads, $V_{sa,eq}$, described in [Tables 3](#) and [4](#) of this report, must be used in lieu of V_{sa} .

4.1.9 Requirements for Interaction of Tensile and Shear Forces: For anchors or groups of anchors that are subject to the effects of combined tensile and shear forces, the design must be performed in accordance with ACI 318-19 17.8, ACI 318-14 17.6 or ACI 318-11 D.7, as applicable.

4.1.10 Requirements for Critical Edge Distance, c_{ac} : In applications where $c < c_{ac}$ and supplemental reinforcement to control splitting of the concrete is not present, the concrete breakout strength in tension for uncracked concrete, calculated according to ACI 318-19 17.6.2, ACI 318-14 17.4.2 or ACI 318-11 D.5.2, as applicable, must be further multiplied by the factor $\psi_{cp,N}$ given by Eq-3:

$$\psi_{cp,N} = \frac{c}{c_{ac}} \quad (\text{Eq-3})$$

whereby the factor $\psi_{cp,N}$ need not be taken less than $\frac{1.5h_{ef}}{c_{ac}}$. For all other cases, $\psi_{cp,N} = 1.0$. In lieu of using ACI 318-19 17.9.5, ACI 318-14 17.7.6 or ACI 318-11 D.8.6, as applicable, values for the critical edge distance c_{ac} must be taken from [Tables 1](#) and [2](#) of this report.

4.1.11 Requirements for Minimum Member Thickness, Minimum Anchor Spacing and Minimum Edge Distance: In lieu of ACI 318-19 17.9.2, ACI 318-14 17.7.1 and 17.7.3, or ACI 318-11 D.8.1 and D.8.3, respectively, as applicable, the values of s_{min} and c_{min} as given in [Tables 1](#) and [2](#) of this report must be used. In lieu of ACI 318-19 17.9.4, ACI 318-14 17.7.5 or ACI 318-11 D.8.5, as applicable, minimum member thicknesses, h_{min} , as given in [Tables 1](#) and [2](#) of this report must be used.

4.1.12 Requirements for Lightweight Concrete: For the use of anchors in lightweight concrete, the modification factor λ_a equal to 0.8λ is applied to all values of $\sqrt{f'_c}$ affecting N_n and V_n .

For ACI 318-19 (2021 IBC), ACI 318-14 (2018 and 2015 IBC) and ACI 318-11 (2012 IBC), λ shall be determined in accordance with the corresponding version of ACI 318.

4.2 Allowable Stress Design (ASD):

4.2.1 General: Design values for use with allowable stress design load combinations calculated in accordance with Section 1605.1 of the 2021 IBC or Section 1605.3 of the 2018, 2015 and 2012 IBC must be established using Eq-4 and Eq-5 as follows:

$$T_{allowable,ASD} = \frac{\phi N_n}{\alpha} \quad (\text{Eq-4})$$

$$V_{allowable,ASD} = \frac{\phi V_n}{\alpha} \quad (\text{Eq-5})$$

where:

$T_{allowable,ASD}$ = Allowable tension load (lbf or kN)

$V_{allowable,ASD}$ = Allowable shear load (lbf or kN)

ϕN_n = Lowest design strength of an anchor or anchor group in tension as determined in accordance with ACI 318 (-19 or -14) Chapter 17 and 2021, 2018 and 2015 IBC Section 1905.1.8, ACI 318-11 Appendix D, and Section 4.1 of this report, as applicable (lbf or kN). For the 2012 IBC, Section 1905.1.9 must be omitted.

ϕV_n = Lowest design strength of an anchor or anchor group in shear as determined in accordance with ACI 318 (-19 or -14) Chapter 17 and 2021, 2018 and 2015 IBC Section 1905.1.8, ACI 318-11 Appendix D, and Section 4.1 of this report, as applicable (lbf or kN). For the 2012 IBC, Section 1905.1.9re must be omitted.

α = Conversion factor calculated as a weighted average of the load factors for the controlling load combination. In addition, α must include all applicable factors to account for non-ductile failure modes and required over-strength.

The requirements for member thickness, edge distance and spacing, described in this report, must apply. An example of Allowable Stress Design values for illustrative purposes is shown in [Table 5](#) and [Figure 3](#).

4.2.2 Requirement for Interaction of Tensile and Shear Forces: The interaction must be calculated and consistent with ACI 318-19 17.8, ACI 318-14 17.6 or ACI 318-11) D.7, as applicable, as follows:

For shear loads $V \leq 0.2V_{allowable,ASD}$, the full allowable load in tension $T_{allowable,ASD}$ must be permitted.

For tension loads $T \leq 0.2T_{allowable,ASD}$, the full allowable load in shear $V_{allowable,ASD}$ must be permitted.

For all other cases: $\frac{T}{T_{allowable}} + \frac{V}{V_{allowable}} \leq 1.2$ (Eq-6)

4.3 Installation:

Installation parameters are provided in [Tables 1](#) and [2](#), and [Figures 1](#) and [2](#) of this report. Anchors must be installed per the manufacturer's published instructions and this report. In case of conflict, this report governs. Anchor locations must comply with this report and the plans and specifications approved by the code official. Anchors must be installed in holes drilled into concrete using carbide-tipped drill bits complying with ANSI B212.15-1994. The nominal drill diameter must be equal to the nominal diameter of the anchor. Prior to anchor installation, the hole must be cleaned in accordance with the manufacturer's published installation instructions. The anchor must be installed into the predrilled hole using a powered impact wrench (all diameters) or installed with a torque wrench ($1/4$ -inch and $3/4$ -inch diameters only) until the proper nominal embedment depth is obtained. The maximum installation impact wrench torque, $T_{impact,max}$, and maximum installation torque, $T_{inst,max}$ for the manual torque wrench must be in accordance with [Tables 1](#) and [2](#).

4.4 Special Inspection:

Periodic special inspection is required, in accordance with Section 1705.1.1 and Table 1705.3 of the 2021, 2018 and 2015 IBC or 2012 IBC, as applicable. The special inspector must make periodic inspections during anchor installation to verify anchor type, anchor dimensions, concrete type, concrete compressive strength, hole dimensions, drill bit size and type, anchor spacing, edge distances, concrete thickness, anchor embedment, maximum impact wrench power and adherence to the manufacturer's published installation instructions. The special inspector must be present as often as required in accordance with the "statement of special inspection." Under the IBC, additional requirements as set forth in Sections 1705, 1706 and 1707 must be observed, where applicable.

5.0 CONDITIONS OF USE:

The CELO BTS concrete screw anchors described in this report comply with, or are a suitable alternative to what is specified in, those codes listed in Section 1.0 of this report, subject to the following conditions:

- 5.1 The anchors must be installed in accordance with the manufacturer's published installation instructions and this report. In case of conflict, this report governs.
- 5.2 Anchor sizes, dimensions, and minimum embedment depths are as set forth in this report.
- 5.3 The $1/4$ -inch to $3/4$ -inch (6.4 mm to 19.1 mm) CELO BTS anchors must be installed in cracked and uncracked normal-weight concrete and lightweight concrete having a specified compressive strength, f'_c , of 2,500 psi to 8,500 psi (17.2 MPa to 58.6 MPa).
- 5.4 The values of f'_c used for calculation purposes must not exceed 8,000 psi (55.2 MPa).
- 5.5 The concrete shall have attained its minimum design strength prior to installation of the anchors.
- 5.6 Strength design values must be established in accordance with Section 4.1 of this report.
- 5.7 Allowable design values must be established in accordance with Section 4.2 of this report.
- 5.8 Anchor spacing(s) and edge distance(s), and minimum member thickness, must comply with [Tables 1](#) and [2](#) of this report.
- 5.9 Reported values for the CELO BTS concrete screw anchors with an internally threaded hex head do not consider the steel insert element which must be verified by the design professional.
- 5.10 Prior to installation, calculations and details demonstrating compliance with this report must be submitted to the code official. The calculations and details must be prepared by a registered design professional where required by the statutes of the jurisdiction in which the project is to be constructed.
- 5.11 Since an ICC-ES acceptance criteria for evaluating data to determine the performance of anchors subjected to fatigue or shock loading is unavailable at this time, the use of these anchors under such conditions is beyond the scope of this report.

- 5.12 The anchors may be installed in regions of concrete where cracking has occurred or where analysis indicates cracking may occur ($f_t > f_c$), subject to the conditions of this report.
- 5.13 The anchors may be used to resist short-term loading due to wind or seismic forces (Seismic Design Categories A through F under the IBC), subject to the conditions of this report.
- 5.14 Anchors are not permitted to support fire-resistance-rated construction. Where not otherwise prohibited by code, CELO BTS concrete screw anchors are permitted for installation in fire-resistance-rated construction provided that at least one of the following conditions is fulfilled:
- Anchors are used to resist wind or seismic forces only.
 - Anchors that support a fire-resistance-rated envelope or a fire-resistance-rated membrane, are protected by approved fire-resistance-rated materials, or have been evaluated for resistance to fire exposure in accordance with recognized standards.
 - Anchors are used to support nonstructural elements.
- 5.15 Anchors have been evaluated for reliability against brittle failure and found to be not significantly sensitive to stress-induced hydrogen embrittlement.
- 5.16 Use of carbon steel anchors with 0.0002-inch (5 μ m) zinc plating as described in Section 3.1 of this report is limited to dry, interior locations.
- 5.17 Special inspection must be provided in accordance with Section 4.4.
- 5.18 CELO BTS concrete screw anchors are manufactured under an approved quality control program with inspections by ICC-ES.

6.0 EVIDENCE SUBMITTED

- 6.1 Data in accordance with the [ICC-ES Acceptance Criteria for Mechanical Anchors in Concrete Elements \(AC193\)](#), dated October 2017, (Editorially revised December 2020), which incorporates requirements in ACI 355.2 (-19 and -07), for use in cracked and uncracked concrete.
- 6.2 Quality control documentation.

7.0 IDENTIFICATION

- 7.1 The ICC-ES mark of conformity, electronic labeling, or the evaluation report number (ICC-ES ESR-5492) along with the name, registered trademark, or registered logo of the report holder (CELO Befestigungssysteme GmbH) must be included in the product label.
- 7.2 In addition, the CELO BTS concrete screw anchors are identified in the field by dimensional characteristics and packaging. A diameter and length marking is stamped on the head of each CELO BTS anchor; these are visible after installation for verification. Packages are identified with the company name and address, anchor name, and anchor size.
- 7.3 The report holder's contact information is as follows:

CELO BEFESTIGUNGSSYSTEME GmbH
INDUSTRIESTRASSE 6
AICHACH, BAVARIA 86551
GERMANY
www.celo.com

TABLE 1—CELO BTS HEX WASHER HEAD ANCHOR INSTALLATION PARAMETERS¹

Characteristic	Symbol	Unit	Nominal Anchor Diameter														
			1/4"		3/8"			1/2"			5/8"				3/4"		
Drill Bit Diameter	d_o	in (mm)	1/4 (6.4)		3/8 (9.5)			1/2 (12.7)			5/8 (15.9)				3/4 (19.1)		
Nominal Embedment Depth	h_{nom}	in (mm)	1 5/8 (41)	2 1/2 (64)	1 5/8 (41)	2 1/2 (64)	3 1/4 (83)	2 1/4 (57)	3 (76)	4 1/4 (108)	3 1/4 (83)	4 (102)	5 (127)	5 1/2 (140)	4 (102)	5 1/2 (140)	6 1/4 (159)
Effective Embedment Depth	h_{ef}	in (mm)	1.24 (31.6)	2.01 (51.1)	1.21 (30.8)	1.98 (50.3)	2.62 (66.5)	1.66 (42.1)	2.30 (58.3)	3.37 (85.5)	2.54 (64.6)	3.19 (80.9)	3.99 (101.3)	4.42 (112.3)	3.14 (79.8)	4.41 (112.1)	5.05 (128.3)
Minimum Hole Depth	h_{hole}	in (mm)	2 (51)	2 7/8 (73)	2 (51)	2 7/8 (73)	3 5/8 (92)	2 5/8 (67)	3 3/8 (86)	4 5/8 (117)	3 5/8 (92)	4 1/2 (114)	5 3/8 (137)	6 (152)	4 1/2 (114)	6 (152)	6 3/4 (171)
Fixture Hole Diameter	d_f	in (mm)	3/8 (9.5)		1/2 (12.7)			5/8 (15.9)			3/4 (19.1)				7/8 (22.2)		
Maximum Installation Torque ²	$T_{inst,max}$	ft.lb (Nm)	21 (29)		N/A			N/A			N/A				103 (140)		
Maximum impact wrench torque rating	$T_{impact,max}$	ft lb (Nm)	135 (185)		135 (185)			260 (350)			260 (350)				440 (600)		
Minimum Concrete Thickness	h_{min}	in (mm)	3 5/8 (91)	4 1/2 (114)	3 5/8 (91)	4 1/2 (114)	5 1/4 (133)	4 1/4 (107)	5 (126)	6 1/4 (158)	5 1/4 (133)	6 (152)	7 (177)	7 1/2 (190)	6 (152)	7 1/2 (190)	8 1/4 (209)
Critical Edge Distance	C_{ac}	in (mm)	1.5 · h_{ef}														
Minimum Edge Distance (C_{min})	C_{min}	in (mm)	1 3/4 (44)														
Minimum Spacing (S_{min})	S_{min}	in (mm)	3 (76)														
Wrench Socket Size	-	in	7/16		9/16			3/4			15/16				1 1/8		

- The tabulated data is to be used in conjunction with the design criteria given in ACI 318 (-19 and -14) Chapter 17 or ACI 318-11 Appendix D, as applicable.
- N/A – Manual torque wrench installation not evaluated.

TABLE 2—CELO BTS HEX COUPLER HEAD ANCHOR INSTALLATION PARAMETERS¹

Characteristic	Symbol	Unit	Nominal Anchor Diameter			
			1/4"		3/8"	
Drill Bit Diameter	d_o	in (mm)	1/4 (6.4)		3/8 (9.5)	
Nominal Embedment Depth	h_{nom}	in (mm)	1 5/8 (41)	2 1/2 (64)	1 5/8 (41)	2 1/2 (64)
Effective Embedment Depth	h_{ef}	in (mm)	1.24 (31.6)	2.01 (51.1)	1.21 (30.8)	1.98 (50.3)
Minimum Hole Depth	h_{hole}	in (mm)	2 (51)	2 7/8 (73)	2 (51)	2 7/8 (73)
Fixture Hole Diameter	d_f	in (mm)	3/8 (9.5)		1/2 (12.7)	
Maximum Installation Torque ²	$T_{inst,max}$	ft.lb (Nm)	21 (29)		N/A	
Maximum impact wrench torque rating	$T_{impact,max}$	ft lb (Nm)	135 (185)		135 (185)	
Minimum Concrete Thickness	h_{min}	in (mm)	4 (102)	4 3/8 (110)	4 (102)	4 3/8 (110)
Critical Edge Distance	C_{ac}	in (mm)	1.5 · h_{ef}			
Minimum Edge Distance (C_{min})	C_{min}	in (mm)	1 3/4 (44)			
Minimum Spacing (S_{min})	S_{min}	in (mm)	3 (76)			
Internal Thread Size	-	-	1/4-20 or 3/8-16 (UNC coarse)			3/8-16 or 1/2-13 (UNC coarse)

- The tabulated data is to be used in conjunction with the design criteria given in ACI 318 (-19 and -14) Chapter 17 or ACI 318-11 Appendix D, as applicable.
- N/A – Manual torque wrench installation not evaluated.

TABLE 3—CELO BTS HEX WASHER HEAD ANCHOR DESIGN INFORMATION^{1,2}

Characteristic	Symbol	Unit	Nominal Anchor Diameter														
			1/4"		3/8"			1/2"			5/8"				3/4"		
Nominal Embedment Depth	h_{nom}	in (mm)	1 5/8 (41)	2 1/2 (64)	1 5/8 (41)	2 1/2 (64)	3 1/4 (83)	2 1/4 (57)	3 (76)	4 1/4 (108)	3 1/4 (83)	4 (102)	5 (127)	5 1/2 (140)	4 (102)	5 1/2 (140)	6 1/4 (159)
Effective Embedment Depth	h_{ef}	in (mm)	1.24 (31.6)	2.01 (51.1)	1.21 (30.8)	1.98 (50.3)	2.62 (66.5)	1.66 (42.1)	2.30 (58.3)	3.37 (85.5)	2.54 (64.6)	3.19 (80.9)	3.99 (101.3)	4.42 (112.3)	3.14 (79.8)	4.41 (112.1)	5.05 (128.3)
Anchor Category	1, 2 or 3	-	3	2	1	1	1	2	2	2	1	1	1	1	2	2	2
Steel Strength in Tension and Shear																	
Minimum specified ultimate strength	f_{uta}	psi (N/mm ²)	101,525 (700)		113,130 (780)			113,130 (780)			113,130 (780)				113,130 (780)		
Minimum specified yield strength	f_y	psi (N/mm ²)	81,220 (560)		90,505 (624)			90,505 (624)			90,505 (624)				90,505 (624)		
Effective stress area (screw anchor body)	A_{se}	in ² (mm ²)	0.0453 (29.2)		0.1020 (65.8)			0.1827 (117.9)			0.2888 (186.3)				0.4145 (267.4)		
Steel Strength in Tension	N_{sa}	lb (kN)	4,585 (20.4)		11,535 (51.3)			20,680 (92.0)			32,665 (145.3)				46,895 (208.6)		
Strength Reduction Factor for Steel Failure in Tension	ϕ_{sa}	-	0.65														
Steel Strength in Shear	V_{sa}	lb (kN)	1,350 (6.0)		3,150 (14.0)			6,745 (30.0)			10,115 (45.0)				15,060 (67.0)		
Steel Strength in Shear, Seismic	$V_{sa,eq}$	lb (kN)	1,125 (5.0)		1,800 (8.0)			3,730 (16.6)			6,880 (30.6)				13,240 (58.9)		
Strength Reduction Factor for Steel Failure in Shear	ϕ_{sa}	-	0.60														
Pullout Strength in Tension³																	
Pullout Strength in Uncracked Concrete	$N_{p,uncr}$	lb (kN)	N/A	4,025 (17.9)	1,395 (6.2)	2,990 (13.3)	N/A	N/A	4,115 (18.3)	7,485 (33.3)	N/A	6,585 (29.3)	8,320 (37.0)	N/A	N/A	N/A	N/A
Pullout Strength in Cracked Concrete	$N_{p,cr}$	lb (kN)	605 (2.7)	1,080 (4.8)	720 (3.2)	1,755 (7.8)	2,630 (11.7)	1,350 (6.0)	2,790 (12.4)	5,195 (23.1)	3,125 (13.9)	4,045 (18.0)	5,195 (23.1)	5,825 (25.9)	4,405 (19.6)	7,330 (32.6)	8,790 (39.1)
Pullout Strength in Cracked Concrete, Seismic	$N_{p,eq}$	lb (kN)	605 (2.7)	1,080 (4.8)	720 (3.2)	1,755 (7.8)	2,630 (11.7)	1,350 (6.0)	2,790 (12.4)	4,720 (21.0)	2,920 (13.0)	4,045 (18.0)	5,015 (22.3)	5,825 (25.9)	4,405 (19.6)	7,330 (32.6)	8,790 (39.1)
Normalization Exponent, Uncracked Concrete	n	-	0.50		0.50			0.50			0.50				0.50		
Normalization Exponent, Cracked Concrete	n	-	0.40		0.50			0.50			0.40				0.50		
Strength Reduction Factor for Pullout Strength in Tension	ϕ_p	-	0.45	0.55	0.65	0.65	0.65	0.55	0.55	0.55	0.65	0.65	0.65	0.65	0.55	0.55	0.55
Concrete Breakout Strength in Tension																	
Effective embedment	h_{ef}	in (mm)	1.24 (31.6)	2.01 (51.1)	1.21 (30.8)	1.98 (50.3)	2.62 (66.5)	1.66 (42.1)	2.30 (58.3)	3.37 (85.5)	2.54 (64.6)	3.19 (80.9)	3.99 (101.3)	4.42 (112.3)	3.14 (79.8)	4.41 (112.1)	5.05 (128.3)
Effectiveness Factor for Uncracked Concrete	k_{uncr}	in-lb (SI)	24 (10.0)	24 (10.0)	24 (10.0)	24 (10.0)	24 (10.0)	24 (10.0)	24 (10.0)	24 (10.0)	24 (10.0)	24 (10.0)	24 (10.0)	24 (10.0)	27 (11.3)	24 (10.0)	24 (10.0)
Effectiveness Factor for Cracked Concrete	k_{cr}	in-lb (SI)	17 (7.1)	17 (7.1)	17 (7.1)	17 (7.1)	17 (7.1)	17 (7.1)	17 (7.1)	17 (7.1)	17 (7.1)	17 (7.1)	17 (7.1)	17 (7.1)	24 (10.0)	21 (8.8)	21 (8.8)
Strength Reduction Factor for Concrete Breakout Strength in Tension	ϕ_{cb}	-	0.45	0.55	0.65	0.65	0.65	0.55	0.55	0.55	0.65	0.65	0.65	0.65	0.55	0.55	0.55
Axial stiffness in service load range in uncracked concrete	β_{uncr}	lb/inch x10 ⁵ (N/mm)	2.719 (48)	1.928 (34)	6.240 (109)	4.502 (79)	3.670 (64)	8.809 (154)	7.079 (124)	5.649 (99)	10.377 (182)	9.099 (159)	8.080 (141)	7.684 (135)	13.204 (231)	11.075 (194)	10.410 (182)
COV for β_{uncr}	v	%	38														
Axial stiffness in service load range in cracked concrete	β_{cr}	lb/inch x10 ⁵ (N/mm)	1.451 (25)	1.100 (19)	3.318 (58)	2.563 (45)	2.179 (38)	4.887 (86)	4.120 (72)	3.487 (61)	6.134 (107)	5.568 (98)	5.117 (90)	4.941 (86.5)	8.063 (141)	7.119 (125)	6.825 (120)
COV for β_{cr}	v	%	48														
Concrete Breakout Strength in Shear																	
Nominal Diameter	d_o^2	in (mm)	0.250 (6.4)		0.375 (9.5)			0.500 (12.7)			0.625 (15.9)				0.750 (19.1)		
Load Bearing Length of Anchor	l_e	in (mm)	1.24 (31.6)	2.01 (51.1)	1.21 (30.8)	1.98 (50.3)	2.62 (66.5)	1.66 (42.1)	2.30 (58.3)	3.37 (85.5)	2.54 (64.6)	3.19 (80.9)	3.99 (101.3)	4.42 (112.3)	3.14 (79.8)	4.41 (112.1)	5.05 (128.3)
Reduction Factor for Concrete Breakout Strength in Shear	ϕ_{cb}	-	0.70														
Concrete Pryout Strength in Shear																	
Coefficient for Pryout Strength	k_{cp}	-	1.0	1.0	1.0	1.0	2.0	1.0	1.0	2.0	2.0	2.0	2.0	2.0	2.0	2.0	2.0
Reduction Factor for Pryout Strength in Shear	ϕ_{cp}	-	0.70														

¹The tabulated data is to be used in conjunction with the design criteria given in ACI 318 (-19 and -14) Chapter 17 or ACI 318-11 Appendix D, as applicable.

²The strength reduction factor applies when the load combinations from the IBC or ACI 318 are used and the requirements of ACI 318-19 17.5.3, ACI 318-14 17.3.3 or ACI 318-11 D.4.3, as applicable, are met. If the load combinations of ACI 318-11 Appendix C are used, the appropriate value of f must be determined in accordance with ACI 318-11 D.4.5.

TABLE 4—CELO BTS HEX COUPLER HEAD ANCHOR DESIGN INFORMATION^{1,2}

Characteristic	Symbol	Unit	Nominal Anchor Diameter			
			1/4"		3/8"	
Drill Bit Diameter	d_o	in (mm)	1/4 (6.4)		3/8 (9.5)	
Nominal Embedment Depth	h_{nom}	in (mm)	1 5/8 (41)	2 1/2 (64)	1 5/8 (41)	2 1/2 (64)
Effective Embedment Depth	h_{ef}	in (mm)	1.24 (31.6)	2.01 (51.1)	1.21 (30.8)	1.98 (50.3)
Anchor Category	1, 2 or 3	-	3	2	1	1
Steel Strength in Tension and Shear						
Minimum specified ultimate strength	f_{uta}	psi (N/mm ²)	101,525 (700)		101,525 (700)	
Minimum specified yield strength	f_y	psi (N/mm ²)	81,220 (560)		81,220 (560)	
Effective stress area (screw anchor body)	A_{se}	in ² (mm ²)	0.0453 (29.2)		0.1020 (65.8)	
Steel Strength in Tension	N_{sa}	lb (kN)	4,585 (20.4)		10,355 (46.1)	
Strength Reduction Factor for Steel Failure in Tension	ϕ_{sa}	-	0.65			
Steel Strength in Shear	V_{sa}	lb (kN)	1,350 (6.0)		3,150 (14.0)	
Steel Strength in Shear, Seismic	$V_{sa,eq}$	lb (kN)	1,125 (5.0)		1,800 (8.0)	
Strength Reduction Factor for Steel Failure in Shear	ϕ_{sa}	-	0.60			
Pullout Strength in Tension³						
Pullout Strength in Uncracked Concrete	$N_{p,uncr}$	lb (kN)	N/A	4,025 (17.9)	2,990 (13.3)	N/A
Pullout Strength in Cracked Concrete	$N_{p,cr}$	lb (kN)	605 (2.7)	1,080 (4.8)	1,755 (7.8)	2,630 (11.7)
Pullout Strength in Cracked Concrete, Seismic	$N_{p,eq}$	lb (kN)	605 (2.7)	1,080 (4.8)	1,755 (7.8)	2,630 (11.7)
Normalization Exponent, Uncracked Concrete	n	-	0.50		0.50	
Normalization Exponent, Cracked Concrete	n	-	0.40		0.50	
Strength Reduction Factor for Pullout Strength in Tension	ϕ_p	-	0.45	0.55	0.65	0.65
Concrete Breakout Strength in Tension						
Effective embedment	h_{ef}	in (mm)	1.24 (31.6)	2.01 (51.1)	1.21 (30.8)	1.98 (50.3)
Effectiveness Factor for Uncracked Concrete	k_{uncr}	in-lb (SI)	24 (10.0)	24 (10.0)	24 (10.0)	24 (10.0)
Effectiveness Factor for Cracked Concrete	k_{cr}	in-lb (SI)	17 (7.1)	17 (7.1)	17 (7.1)	17 (7.1)
Strength Reduction Factor for Concrete Breakout Strength in Tension	ϕ_{cb}	-	0.45	0.55	0.65	0.65
Axial stiffness in service load range in uncracked concrete	β_{uncr}	lb/inch x10 ⁵ (N/mm)	2.719 (48)	1.928 (34)	6.240 (109)	4.502 (79)
COV for β_{uncr}	v	%	38			
Axial stiffness in service load range in cracked concrete	β_{cr}	lb/inch x10 ⁵ (N/mm)	1.451 (25)	1.100 (19)	3.318 (58)	2.563 (45)
COV for β_{cr}	v	%	48			
Concrete Breakout Strength in Shear						
Nominal Diameter	d_o^2	in (mm)	0.250 (6.4)		0.375 (9.5)	
Load Bearing Length of Anchor	l_e	in (mm)	1.24 (31.6)	2.01 (51.1)	1.21 (30.8)	1.98 (50.3)
Reduction Factor for Concrete Breakout Strength in Shear	ϕ_{cb}	-	0.70			
Concrete Pryout Strength in Shear						
Coefficient for Pryout Strength	k_{cp}	-	1.0	1.0	1.0	1.0
Reduction Factor for Pryout Strength in Shear	ϕ_{cp}	-	0.70			

¹The tabulated data is to be used in conjunction with the design criteria given in ACI 318 (-19 and -14) Chapter 17 or ACI 318-11 Appendix D, as applicable.
²The strength reduction factor applies when the load combinations from the IBC or ACI 318 are used and the requirements of ACI 318-19 17.5.3, ACI 318-14 17.3.3 or ACI 318-11 D.4.3, as applicable, are met. If the load combinations of ACI 318-11 Appendix C are used, the appropriate value of f must be determined in accordance with ACI 318-11 D.4.5.

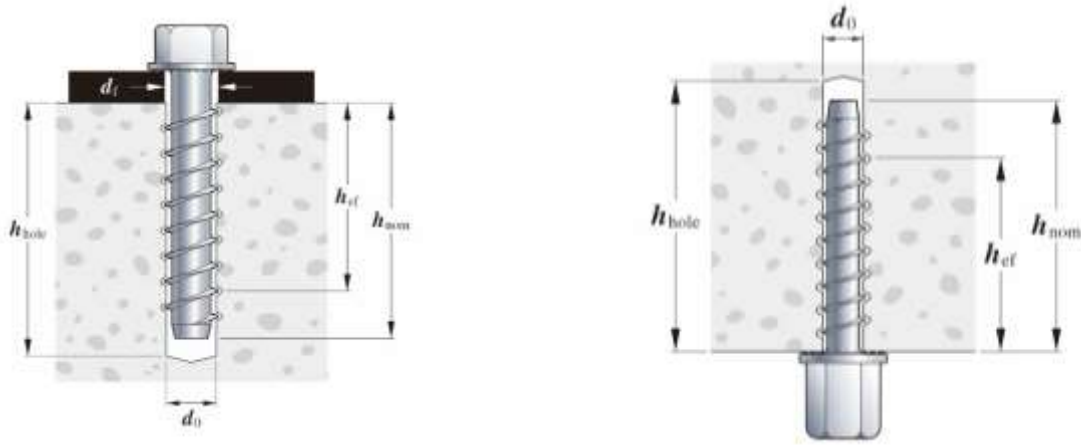

FIGURE 1—CELO BTS HEX WASHER HEAD DETAIL (Left Picture) AND CELO BTS HEX COUPLER HEAD INTERNALLY THREADED ANCHOR DETAIL (Right Picture)

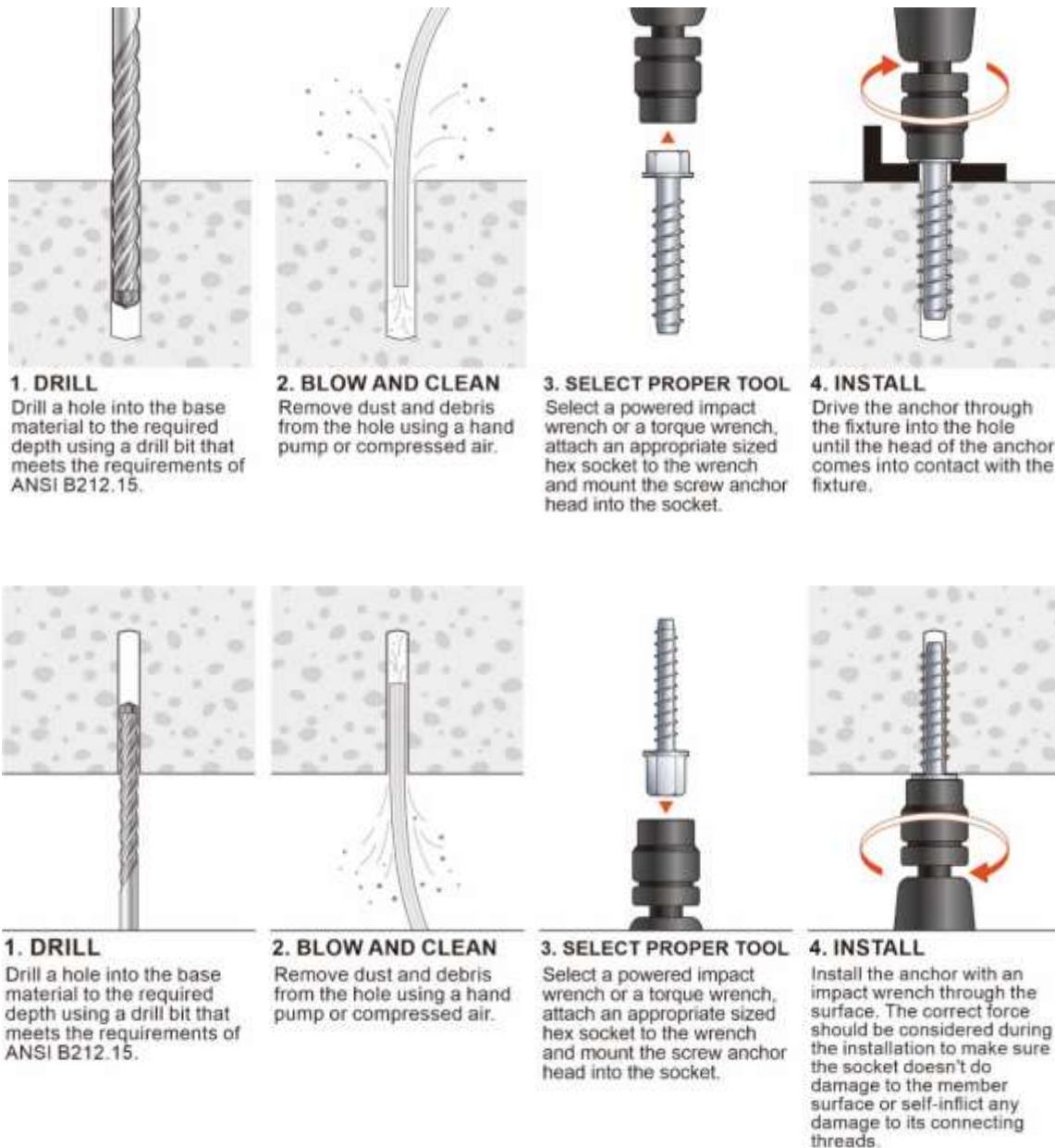

FIGURE 2—MANUFACTURER'S PUBLISHED INSTALLATION INSTRUCTIONS

TABLE 5—EXAMPLE HEX WASHER HEAD ALLOWABLE STRESS DESIGN VALUES FOR ILLUSTRATIVE PURPOSES^{1,2,3,4,5,6,7,8,9,10}

Nominal Anchor Diameter d_o (inch)	Nominal Embedment Depth h_{nom} (inch)	Allowable Tension Load $T_{allowable,ASD}$ (lb)
1/4	1 5/8	504
1/4	2 1/2	1271
3/8	1 5/8	613
3/8	2 1/2	1313
3/8	3 1/4	2235
1/2	2 1/4	954
1/2	3	1529
1/2	4 1/4	2759
5/8	3 1/4	2133
5/8	4	2892
5/8	5	3654
5/8	5 1/2	4897
3/4	4	2791
3/4	5 1/2	4130
3/4	6 1/4	5061

1. Single anchor.
2. Static tension loading only.
3. Concrete determined to remain uncracked for the life of the anchorage.
4. Load combinations taken from ACI 318 (-19 or -14) Section 5.3 or ACI 318-11 Section 9.2, as applicable with no seismic loading.
5. 30% Dead Load (D) and 70% Live Load (L), controlling load combination 1.2D + 1.6L.
6. Calculation of the weighted average for $\alpha = 1.2 \times 0.3 + 1.6 \times 0.7 = 1.48$
7. Normal weight concrete, $f_c = 2,500$ psi.
8. $C_{a1} = C_{a2} \geq C_{ac}$
9. Concrete thickness $h \geq h_{min}$.
10. Values are for Condition B (supplementary reinforcement in accordance with ACI 318 (-19 or -14) 17.3.3 or ACI 318-11 D.4.3 is not provided).

Illustrative procedure of Allowable Stress Design calculation. Method ACI 318 (-19 and -14), Chapter 17

Per the figure below and the following information:

- 2 anchors CELO BTS 1/2 in x 3 in anchor length
- Concrete: strength 2,500 psi, uncracked, 5 1/2 inches thick
- $h_{ef} = 2.30$ in
- Anchor Layout: as per sketch
- Static or quasi-static loads

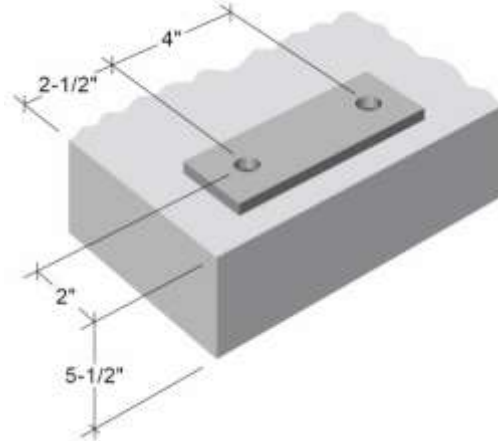

Step	ACI 318-19 Section Reference	ACI 318-14 Section Reference	ESR Section Reference	CALCULATIONS
1	17.9	17.7	Section 4.1.11 Table 1	Verify spacing / edge distance / member thickness $s = 4 \text{ in} > 3 \text{ in} \rightarrow \text{verified}$ $c_{a1} = 2\text{-}1/2 \text{ in} > 1\text{-}3/4 \text{ in} \rightarrow \text{verified}$ $c_{a2} = 2 \text{ in} > 1\text{-}3/4 \text{ in} \rightarrow \text{verified}$ $h = 5 \text{ } 1/2 \text{ in} > 5 \text{ in} \rightarrow \text{verified}$
2	17.6.1.2	17.4.1.2	Section 4.1.2 Table 2	Calculate steel capacity on a single fastener loaded in tension $\phi N_{sa} = (0.65) (20,680) = 13,442 \text{ lbf}$ Group of fasteners $\phi N_s = n \phi N_{sa} = (2) (13,442) = \mathbf{26,884 \text{ lbf}}$
3	17.6.2.1	17.4.2.1	4.1.3	Calculation concrete strength capacity on the group of fasteners loaded in tension $\phi N_{cbg} = \phi \frac{A_{Nc}}{A_{Nco}} \psi_{ec,N} \psi_{ed,N} \psi_{c,N} \psi_{cp,N} N_b$
3.1	17.6.2.1	17.4.2.1	Table 2	$A_{Nc} = (c_{a1} + 1.5 h_{ef}) (c_{a2} + s + 1.5 h_{ef}) = (2 + 3.45) (2.5 + 4 + 3.45) = 54.23$ $A_{Nco} = 9 (h_{ef})^2 = 9 (2.30)^2 = 47.61$
3.2	17.6.2.4	17.4.2.4		No load eccentricity $\rightarrow e_v = 0 \rightarrow \psi_{ec,N} = 1.00$
3.3	17.6.2.5	17.4.2.5	Table 2	$C_{a,min} < 1.5 h_{ef} \rightarrow \psi_{ed,N} = 0.7 + 0.3 \frac{C_{a,min}}{1.5 h_{ef}} = 0.7 + 0.3 \frac{2}{3.45} = 0.87$
3.4	17.6.2.6	17.4.2.6	4.1.3	Unracked concrete $\rightarrow \psi_{c,N} = 1.00$ (use k_{unscr})
3.5	17.6.2.7	17.4.2.7	4.1.10	Unracked concrete $\rightarrow \psi_{cp,N} = c_{a2} / c_{ac} = 2 / 3.45 = 0.59$
3.6	17.6.2.2	17.4.2.2	4.1.3	$N_b = k_{unscr} \lambda_a \sqrt{f'_c} h_{ef}^{1.5} = (24) (1.0) \sqrt{2500} (2.30)^{1.5} = 4,185 \text{ lbf}$
	17.6.2.1	17.4.2.1	4.1.3	thus $\phi N_{cbg} = (0.55) \frac{54.23}{47.61} (1.0)(0.87)(0.59)(4,185) = \mathbf{1,346 \text{ lbf}}$
4	17.6.3.1	17.4.3.1	Section 4.1.4 Table 2	Calculate pull out strength on single fastener loaded in tension $\phi N_{p,f} = \phi \psi_{c,p} N_{p,2500} \left(\frac{f'_c}{2,500} \right)^n = (0.55)(1.0) (4,115) \left(\frac{2,500}{2,500} \right)^{0.35} = 2,263 \text{ lbf}$ Group of fasteners $\phi N_p = n \phi N_{p,f} = (2) (2,263) = \mathbf{4,526 \text{ lbf}}$
5	17.5.1.3	17.3.1.1	-	Governing tension strength: Minimum value of steel, concrete breakout, pull out: $\phi N_t = \min [\phi N_s; \phi N_c; \phi N_p] = \mathbf{1,346 \text{ lbf}}$
6	5.3	5.3	Section 4.2.1	Calculation of conversion factor, α , for allowable stress design $\alpha = (1.2) D + (1.6) L = (1.2) (0.30) + (1.6) (0.70) = \mathbf{1.48}$
7	-	-	Section 4.2.1	Calculation of allowable stress design in tension $T_{allowable,ASD} = \frac{\phi N_t}{\alpha} = \frac{1,346}{1.48} = \mathbf{909 \text{ lbf}}$

FIGURE 3—EXAMPLE STRENGTH DESIGN CALCULATION INCLUDING ASD CONVERSION, FOR ILLUSTRATIVE PURPOSES

DIVISION: 03 00 00—CONCRETE
Section: 03 16 00—Concrete Anchors

DIVISION: 05 00 00—METALS
Section: 05 05 19—Post-Installed Concrete Anchors

REPORT HOLDER:

CELO BEFESTIGUNGSSYSTEME GmbH

EVALUATION SUBJECT:

CELO BTS CONCRETE SCREW ANCHORS IN CRACKED AND UNCRACKED CONCRETE

1.0 REPORT PURPOSE AND SCOPE

Purpose:

The purpose of this evaluation report supplement is to indicate that the CELO BTS concrete screw anchors in cracked and uncracked concrete, described in ICC-ES evaluation report [ESR-5492](#), have also been evaluated for compliance with the codes noted below as adopted by the Los Angeles Department of Building and Safety (LADBS).

Applicable code editions:

- 2020 *City of Los Angeles Building Code* (LABC)
- 2020 *City of Los Angeles Residential Code* (LARC)

2.0 CONCLUSIONS

The CELO BTS concrete screw anchors in uncracked concrete, described in Sections 2.0 through 7.0 of the evaluation report [ESR-5492](#), comply with the LABC Chapter 19, and the LARC, and are subject to the conditions of use described in this supplement.

3.0 CONDITIONS OF USE

The CELO BTS concrete screw anchors in cracked and uncracked concrete described in this evaluation report supplement must comply with all of the following conditions:

- All applicable sections in the evaluation report [ESR-5492](#).
- The design, installation, conditions of use and identification of the anchors are in accordance with the 2018 *International Building Code*® (IBC) provisions noted in the evaluation report [ESR-5492](#).
- The design, installation and inspection are in accordance with additional requirements of LABC Chapters 16 and 17 as applicable.
- Under the LARC, an engineered design in accordance with LARC Section R301.1.3 must be submitted.
- The allowable strength and design strength values listed in the evaluation report and tables are for the connection of the anchors to the concrete. The connection between the anchors and the connected members shall be checked for capacity (which may govern).
- For use in wall anchorage assemblies to flexible diaphragm applications, anchors shall be designed per the requirements of City of Los Angeles Information Bulletin P/BC 2020-071.

This supplement expires concurrently with the evaluation report, issued May 2024.

DIVISION: 03 00 00—CONCRETE

Section: 03 16 00—Concrete Anchors

DIVISION: 05 00 00—METALS

Section: 05 05 19—Post-Installed Concrete Anchors

REPORT HOLDER:

CELO BEFESTIGUNGSSYSTEME GmbH

EVALUATION SUBJECT:

CELO BTS CONCRETE SCREW ANCHORS IN CRACKED AND UNCRACKED CONCRETE

1.0 REPORT PURPOSE AND SCOPE

Purpose:

The purpose of this evaluation report supplement is to indicate that the CELO BTS concrete screw anchors in cracked and uncracked concrete, described in ICC-ES evaluation report ESR-5492, have also been evaluated for compliance with the codes noted below.

Applicable code editions:

- 2022 *California Building Code* (CBC)

For evaluation of applicable chapters adopted by the California Office of Statewide Health Planning and Development (OSHPD) AKA: California Department of Health Care Access and Information (HCAI) and the Division of the State Architect (DSA), see Sections 2.1.1 and 2.1.2 below.

- 2022 *California Residential Code* (CRC)

2.0 CONCLUSIONS

2.1 CBC:

The CELO BTS concrete screw anchors in cracked and uncracked concrete, described in Sections 2.0 through 7.0 of the evaluation report ESR-5492, comply with CBC Chapter 19, provided the design and installation are in accordance with the 2021 *International Building Code*® (IBC) provisions, as applicable, noted in the evaluation report and the additional requirements of CBC Chapters 16 and 17.

2.1.1 OSHPD:

The applicable OSHPD Sections and Chapters of the CBC are beyond the scope of this supplement.

2.1.2 DSA:

The applicable DSA Sections and Chapters of the CBC are beyond the scope of this supplement.

2.2 CRC:

The CELO BTS concrete screw anchors in cracked and uncracked concrete, described in Sections 2.0 through 7.0 of the evaluation report ESR-5492, comply with the CRC Section R301.1.3, provided the design and installation are in accordance with the 2021 *International Building Code*® (IBC), provisions, as applicable, noted in the evaluation report, and the additional requirements of CBC Chapters 16 and 17.

This supplement expires concurrently with the evaluation report, issued May 2024.

DIVISION: 03 00 00—CONCRETE
Section: 03 16 00—Concrete Anchors

DIVISION: 05 00 00—METALS
Section: 05 05 19—Post-Installed Concrete Anchors

REPORT HOLDER:

CELO BEFESTIGUNGSSYSTEME GmbH

EVALUATION SUBJECT:

CELO BTS CONCRETE SCREW ANCHORS IN CRACKED AND UNCRACKED CONCRETE

1.0 REPORT PURPOSE AND SCOPE

Purpose:

The purpose of this evaluation report supplement is to indicate that the CELO BTS concrete screw anchors in cracked and uncracked concrete, described in ICC-ES evaluation report ESR-5492, have also been evaluated for compliance with the codes noted below.

Applicable code editions:

- 2020 *Florida Building Code—Building*
- 2020 *Florida Building Code—Residential*

2.0 CONCLUSIONS

The CELO BTS concrete screw anchors in cracked and uncracked concrete, described in Sections 2.0 through 7.0 of ICC-ES evaluation report ESR-5492, comply with the *Florida Building Code—Building* or the *Florida Building Code—Residential*, provided the design requirements are determined in accordance with the *Florida Building Code—Building* or the *Florida Building Code—Residential*, as applicable. The installation requirements noted in ICC-ES evaluation report ESR-5492 for the 2018 *International Building Code*® meet the requirements of the *Florida Building Code—Building* or the *Florida Building Code—Residential*, as applicable.

Use of the CELO BTS concrete screw anchors in cracked and uncracked concrete, have also been found to be in compliance with the High-Velocity Hurricane Zone provisions of the *Florida Building Code—Building* and the *Florida Building Code—Residential* with the following condition:

- a) For anchorage of wood members, the connection subject to uplift must be designed for no less than 700 pounds (3114 N).

For products falling under Florida Rule 61G20-3, verification that the report holder's quality assurance program is audited by a quality assurance entity approved by the Florida Building Commission for the type of inspections being conducted is the responsibility of an approved validation entity (or the code official when the report holder does not possess an approval by the Commission).

This supplement expires concurrently with the evaluation report, issued May 2024.