

ICC-ES Evaluation Report

ESR-5257

Reissued September 2024

Subject to renewal September 2025

ICC-ES Evaluation Reports are not to be construed as representing aesthetics or any other attributes not specifically addressed, nor are they to be construed as an endorsement of the subject of the report or a recommendation for its use. There is no warranty by ICC Evaluation Service, LLC, express or implied, as to any finding or other matter in this report, or as to any product covered by the report.

Copyright © 2024 ICC Evaluation Service, LLC. All rights reserved.

<p>DIVISION: 05 00 00—METALS</p> <p>Section: 05 40 00—Cold-Formed Metal Framing</p>	<p>REPORT HOLDER:</p> <p>NEW CASTLE STEEL, INC.</p>	<p>EVALUATION SUBJECT:</p> <p>NEW CASTLE STEEL DECK SYSTEM</p>	
---	---	--	---

1.0 EVALUATION SCOPE

Compliance with the following codes:

- 2021 and 2018 [International Building Code® \(IBC\)](#)
- 2021 and 2018 [International Residential Code® \(IRC\)](#)

Properties evaluated:

- Structural
- Surface Burning Characteristics

2.0 USES

The New Castle Steel Deck system is a cold-formed steel structural framing system that is used as the substructure of exterior decks.

3.0 DESCRIPTION

3.1 General:

The New Castle Steel Deck System consists of cold-formed steel structural members (joists, tracks, beams and posts), cold-formed steel connectors/brackets, and fasteners as shown in [Figure 1](#) and in the manufacturer’s installation guide (V01), dated March 2022. The evaluation scope is limited to the framing members. Evaluation of connectors/brackets, fasteners and connections are outside the scope of this evaluation report.

3.2 Cold-formed Steel Structural Members:

All structural members are galvanized with minimum G60 coating as described in ASTM A653. Members are manufactured with no punchouts.

Joists are available in two sizes and tracks in one size as shown in [Figure 2](#). Joists and tracks have two layers of proprietary, baked on coating on top of the galvanized surfaces. The 1⁵/₈” joists are factory formed from steel coils conforming to ASTM A653 Grade 33. The 2” joists are factory formed from steel coils conforming to ASTM A653 Grade 50 Class 1. The track has a 14Ga thickness and is factory formed steel coils conforming to ASTM A653 Grade 50 Class 1.

Posts are available in one size: 6 x 6 x 1/8-inch square posts with inside radius of 0.125 inch (3.2 mm) as shown in [Figure 3](#). Posts comply with ASTM A500 Grade C and are powder coated on top of the galvanized surfaces.

Thicknesses of joists, tracks and posts are:

Joist	Nominal Thick.	Minimum Base-Metal Thick. (in.)	Design Thick. (in.)
1 ⁵ / ₈ " Joist	18Ga	0.044	0.0451
2" Joist	14Ga	0.067	0.0705
Track	14Ga	0.067	0.0705
Post	1/8"	0.110	0.116

The beams are available in two models: single and double box beams. The single box beam is factory assembled from a 2-inch joist and a 1¹/₄-inch track that are fastened to each other at the top and bottom flanges using #10 self-tapping screws as shown in [Figure 4](#). The screws are spaced at 12 inches (305 mm) on-center. The double box beam is field assembled from two single box beams that are fastened to each other at the middle of joists webs using the same screws as shown in [Figure 4](#).

3.3 Fasteners:

The fasteners that are used to form the single box and double box beams are #10-16 X 3/4" hex-head self-tapping screws (#2 drill point). The screws must be corrosion resistant and must conform to ASTM C1513.

3.4 Surface Burning Characteristics Evaluation:

The galvanized New Castle Steel joists, tracks, and beams with a proprietary coating were tested in accordance with ASTM E84. The coating of joists, tracks, and beams is classified as Class A interior finish material in accordance with Section 803.1.2 of the IBC.

4.0 DESIGN AND INSTALLATION

4.1 General:

The framing members and their connections must be designed and installed in accordance with IBC Section 2210 using the section properties referenced in Section 3.0.

4.2 Design:

Section properties and design values of the framing members are provided in [Table 1](#). All design values have been determined in accordance with the North American Specification for Design of Cold-formed Steel Structural Members (AISI S100-16 w/S2-20). The allowable capacities are for use with Allowable Strength Design (ASD) method. The allowable moments are for flexural members installed with the compression flange continuously braced. For other conditions of compression flange bracing, the allowable moment must be determined in accordance with AISI S100. The design of members must address web crippling and combined loading conditions, as applicable, in accordance with AISI S100.

Under the IRC, the use of cold-formed steel framing members must be limited to engineered structures, in accordance with IRC Section R301.1.3.

4.3 Installation:

The framing members must be installed in accordance with the applicable code, the approved plans and this report. If there is a conflict between the plans submitted for approval and this report, this report governs. The approved plans must be made available at the jobsite at all times.

5.0 CONDITIONS OF USE:

The New Castle Steel Deck System described in this report complies with, or is a suitable alternative to what is specified in, those codes listed in Section 1.0 of this report, subject to the following conditions:

- 5.1 Minimum uncoated base-metal thickness of the cold-formed steel members as delivered to the jobsite must be as specified in Section 3.2.
- 5.2 Complete plans and calculations verifying compliance with this report must be submitted to the code official for each project at the time of permit application. The calculations and drawings must be prepared in accordance with the IBC or IRC, as applicable.
- 5.3 New Castle Steel Deck System framing members are manufactured under an approved quality control program by ICC-ES.

6.0 EVIDENCE SUBMITTED

- 6.1 Data in accordance with the [ICC-ES Acceptance Criteria for Cold-formed Steel Framing Members \(AC46\)](#), dated October 2019 (editorially revised December 2020).
- 6.2 Test report in accordance with ASTM E84, Standard Test Method for Surface Burning Characteristics of Building Materials.

7.0 IDENTIFICATION

- 7.1 The ICC-ES mark of conformity, electronic labeling, or the evaluation report number (ICC-ES ESR-5257) along with the name, registered trademark, or registered logo of the report holder (New Castle Steel, Inc.) must be included in the product label.
- 7.2 At a spacing not exceeding 96 inches (2440 mm) on center, each cold formed steel member is stamped or embossed with the item number as described in [Table 1](#); the minimum uncoated base-metal thickness in mils or decimal inches; the minimum specified yield strength; and the designation of coating.
- 7.3 The report holder's contact information is the following:

NEW CASTLE STEEL, INC.
1000 PINE MILL DRIVE
MARIETTA, GEORGIA 30066
(888) 960-0808
www.ncsteel.com
info@ncsteel.com

Definitions of symbols for use with [Table 1](#):

F_y :	Yield Strength
K_ϕ :	Distortional buckling moment (M_{ad}) is calculated without the beneficial effect of sheathing to rotational stiffness, $K_\phi = 0$.
A:	The cross-sectional area of the full cross-section.
WT:	The weight per foot of the cross-section of the member.
t:	Design base-metal thickness without coating.
I_x :	Moment of inertia of the gross section about the strong axis (X-X).
S_x :	Elastic section modulus of the gross section about the strong axis (X-X)
I_{ex} :	Effective moment of inertia about the strong axis (X-X).
KL:	Effective unbraced length of post.
P_a :	Allowable (ASD) axial compression capacity.
M_{al} :	Allowable (ASD) bending moment based on local buckling.
M_{ad} :	Allowable (ASD) bending moment based on distortional buckling, assuming $K_\phi = 0$.
V_a :	Allowable (ASD) strong axis shear.

TABLE 1—SECTION PROPERTIES AND DESIGN VALUES OF FRAMING MEMBERS¹

MEMBER		F _y (ksi)	WT (lb/ft)	GROSS SECTION PROPERTIES				ALLOWABLE CAPACITIES (ASD)				
Descrip.	Item No.			t (in.)	A (in. ²)	I _x (in. ⁴)	S _x (in. ³)	Axial Compression		Moment		Shear V _a (lbs)
								KL (ft)	P _a (lbs)	M _{al} (ft-lb)	M _{ad} (ft-lb)	
1 ⁵ / ₈ " Joist	NCS202204, NCS202205, or NCS202206	33	1.81	0.0451	0.53	4.51	1.13	---	---	1,530	1,540	1,085
2" Joist	NCS202207, NCS202208, or NCS202209	50	3.37	0.0705	0.91	8.09	2.02	---	---	4,795	4,425	4,155
Track	NCS202201, NCS202202, or NCS202203	50	2.43	0.0705	0.73	5.67	1.39	---	---	2,910	---	4,075
Single Box Beam		---	5.8	---	1.63	13.76	3.41	---	---	7,710	---	8,230
Double Box Beam		---	11.6	---	3.26	27.52	6.82	---	---	15,420	---	16,460
6 x 6 Post	NCS202225, NCS202226, NCS202228, or NCS202229	50	9.2	0.116	2.69	15.44	5.15	0.0	59,630	11,395	---	24,080
								6.0	57,105			
								12.0	50,110			

For SI Units: 1 inch = 25.4 mm, 1 pound = 4.448 N

¹For serviceability, the effective moment of inertia for deflection, I_{ex} = I_x.

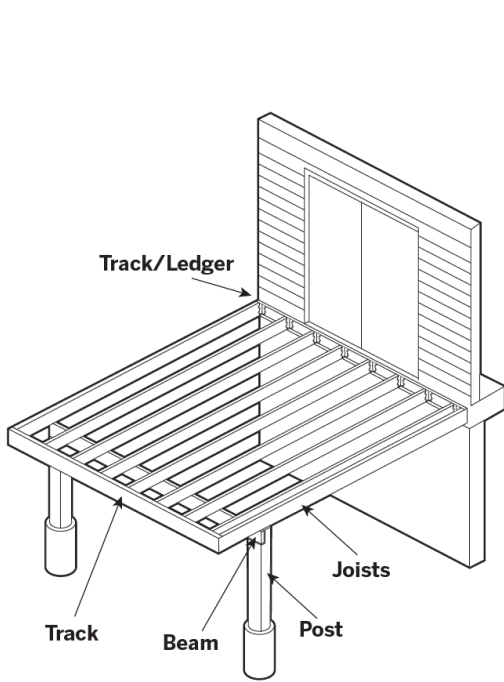

FIGURE 1—NEW CASTLE FRAMING SYSTEM

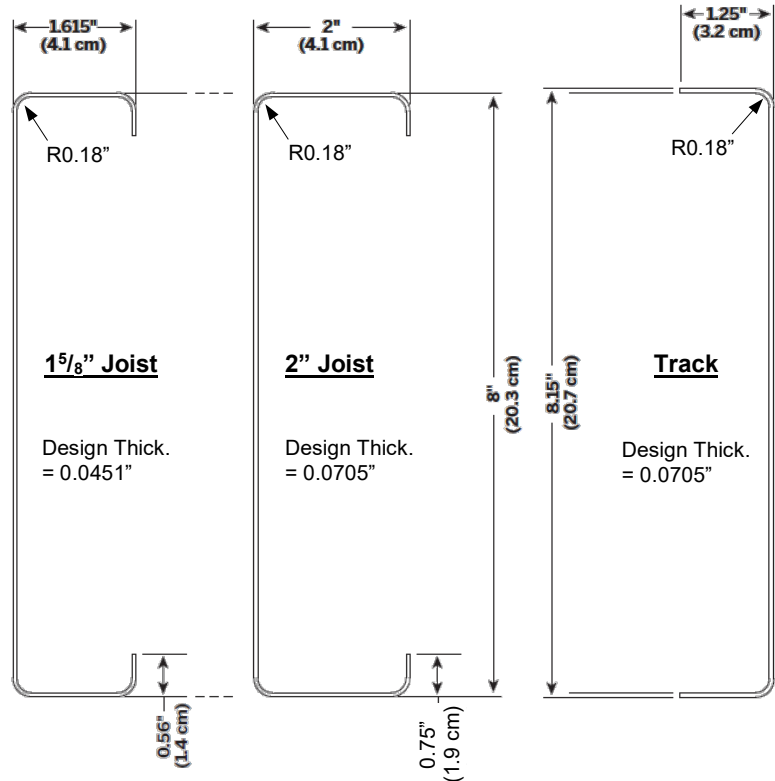

FIGURE 2—NEW CASTLE FRAMING JOISTS AND TRACKS

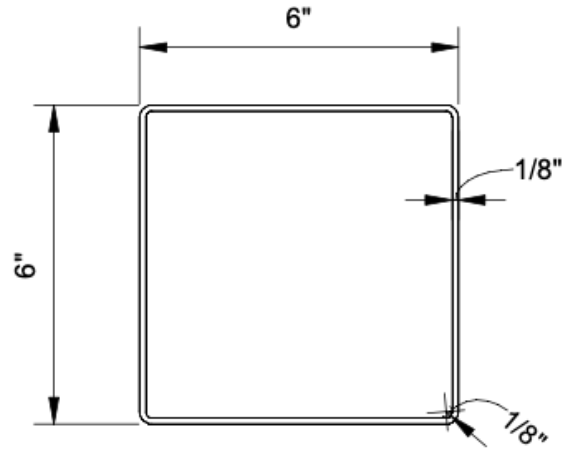

FIGURE 3—NEW CASTLE SUPPORT POST

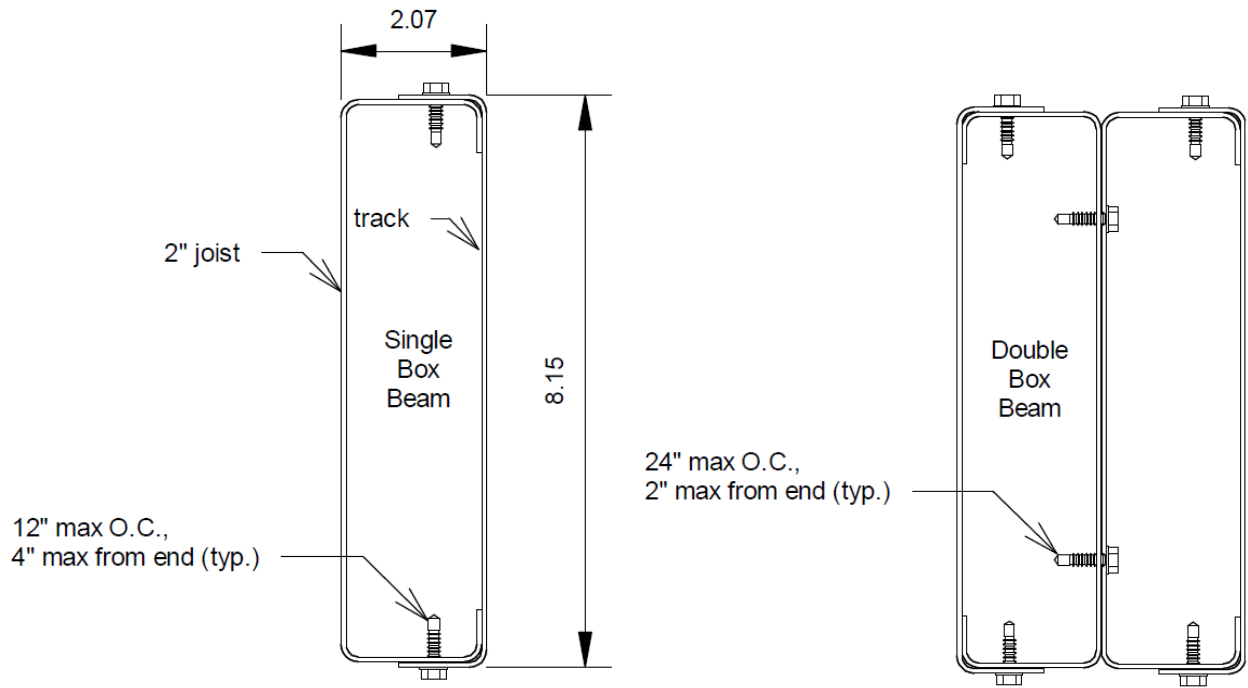

FIGURE 4—NEW CASTLE FRAMING BEAMS