

# ICC-ES Evaluation Report

**ESR-5184**

Reissued June 2024

Revised July 2024

Subject to renewal January 2025

ICC-ES Evaluation Reports are not to be construed as representing aesthetics or any other attributes not specifically addressed, nor are they to be construed as an endorsement of the subject of the report or a recommendation for its use. There is no warranty by ICC Evaluation Service, LLC, express or implied, as to any finding or other matter in this report, or as to any product covered by the report.

Copyright © 2024 ICC Evaluation Service, LLC. All rights reserved.

<p><b>DIVISION: 03 00 00—</b> <b>CONCRETE.</b></p> <p><b>Section: 03 37 00—</b> <b>Specialty Placed</b> <b>Concrete</b></p>	<p><b>REPORT HOLDER:</b></p> <p><b>INDUSTRIAL BEARING</b> <b>BUILDING CO. (IBBCO)</b></p> <p><b>ADDITIONAL LISTEES:</b></p> <p><b>ASALEEB ALIAN</b> <b>INDUSTRIES CO.</b></p> <p><b>DALATAMEER</b> <b>INTERNATIONAL CO.</b></p> <p><b>INNOVATIVE</b> <b>INTEGRATED</b> <b>INDUSTRIES</b></p>	<p><b>EVALUATION SUBJECT:</b></p> <p><b>EMMEDUE WALL,</b> <b>FLOOR AND ROOF</b> <b>PANELS</b></p>	
---	--	---	---

## 1.0 EVALUATION SCOPE

**Compliance with the following codes:**

- 2018 [Saudi Building Code-General](#) – SBC 201-CR
- 2018 [Saudi Building Code for Concrete Structures](#) – SBC 304-CR

**Properties evaluated:**

- Structural
- Surface-burning characteristics
- Fire-resistance-rate assemblies
- Weather resistance
- Physical properties

## 2.0 USES

The Emmedue panels are a structural composite panel system used as load-bearing and nonload-bearing walls, floor and roof panels. The panels may be used in fire-resistance-rated and non-fire-resistance-rated construction. The panels are evaluated for use in buildings of Type I, II, III or IV (noncombustible) construction when installed in accordance with Section 5.2 of this report. The panels are also evaluated for use in Type V (combustible) construction when installed in accordance with this report.

## 3.0 SYSTEM COMPONENTS:

**3.1 Number of Stories:** For use as a basic seismic force-resisting system under Seismic Design Categories A and B, there is no height limit based on Table 10.2 of the 2018 Saudi Loading Code (SBC 301-CR). The panels have not been evaluated for use under Seismic Design Categories C or higher.

In addition, the maximum number of stories and maximum building height above grade plane must be determined in accordance Section 504 of the SBC 201-CR based on the construction type and occupancy classification.

**3.1.1 Building Area:** The maximum building area must be determined in accordance with Section 506 of SBC 201-CR based on the type of construction and occupancy classification.

**3.2 Structure:** Applicable design loads (dead, live, etc.) must be determined in accordance with Chapter 16 of the SBC 201-CR and must not exceed the maximum distributed load that the system can carry in accordance with the following:

- 1) Maximum (allowable) load capacities, including axial, transverse and shear capacities, of wall panels must be in accordance with [Tables 1](#) and [2](#) of this report.
- 2) Maximum (allowable) load capacities, including axial, transverse and shear capacities, of roof and floor panels must be in accordance with [Tables 3](#) and [4](#) of this report.

For additional design information, see Section 5.1 of this report.

**3.3 Floor and Roof Panel Dimensions:** The PSS80 and PSS150 are available in 2.43 or 3.65 m lengths. For additional floor and roof panel information, see Section 4.1.

**3.4 Wall Panel Dimensions:** The wall panels are available in 2.43, 3.04, 3.65 and 4.26 m heights. For additional wall panel information, see Section 4.1.

**3.5 Detailing:** For typical wall composition detail, see [Figure 1](#).

**3.5.1 Floor-Wall Junction Details:** See [Figure 7](#).

**3.5.2 Roof-Wall Junction Details:** See [Figure 8](#).

**3.6 Roofing:** Roof coverings must comply with Chapter 15 of the SBC 201-CR and are outside the scope of this report.

**3.7 Foundation:** See Section 5.3 for information regarding the installation of panels to foundations.

**3.7.1 Stairs:** Stair design is outside the scope of this report.

**3.8 Fire Safety:** See Section 5.2 for fire-resistance ratings for wall and floor/roof panel assemblies.

For flame-spread index and smoke-developed index information of the EPS core of panels, see Section 3.3.1. For thermal barrier, installation in accordance with Section 4.1 complies with SBC-201-CR Section 2603.4.1.1.

**3.9 Site Preparation and Resistance to Moisture:** See Section 5.3 and Section 6.2.

**3.10 Materials and Workmanship:** See Section 4.2 and 5.3 of this report for materials and installation information, respectively.

**3.11 Sound Transmission:** Airborne sound transmission through walls and floors and impact sound transmission has not been evaluated.

**3.12 Ventilation:** Ventilation must comply with Section 1203 of the SBC 201-CR and applicable sections of the SBC 601-CR and SBC 602-CR.

**3.13 Heat Producing Appliances:** Protection of building against heat producing appliances has not been evaluated.

**3.14 Conservation of Fuel and Energy:** Conservation of Fuel and Energy has not been evaluated.

**3.15 Access for People with Disabilities:** Accessibility must comply with Chapter 11 of the SBC.

## 4.0 DESCRIPTION

### 4.1 General:

The Emmedue panels consist of a single insulating foam plastic board (EPS core) with a grid of welded wire reinforcement on each face of the insulating panel connected by steel transverse wires. A layer of shotcrete is applied to each face of the panels, over the welded woven steel, at the jobsite.

The Emmedue wall panels are designated PSM80, with an effective total thickness of 102 mm consisting of EPS foam cores with welded woven steel on each face, where the PSM80 is covered with a minimum thickness of 25 mm shotcrete on each outer face.

The Emmedue floor-roof panels consist of an insulating foam plastic board (EPS core) with a layer of welded wire reinforcement on each face and a grid of welded wire reinforcement connected by steel transverse wires. The bottom surface of the floor-roof panels is shot with a layer of shotcrete, over the welded woven steel, at the jobsite. The top surface of the floor-roof panels is covered with a layer of placed concrete, over the welded

woven steel, at the jobsite. The Emmedue floor and roof panels are designated either PSS80 with an effective total thickness of 102 mm consisting of EPS foam cores with welded woven steel on each face, or PSS150 with an effective total thickness of 152 mm consisting of EPS foam cores with welded woven steel on each face, where either PSS80 or PSS150 is covered with a minimum thickness of 51 mm of concrete on the top surface and a minimum thickness of 25 mm shotcrete on the bottom surface.

The Emmedue wall panels and floor-roof panels are preformed and delivered to the jobsite for erection and placement of shotcrete and concrete. See [Table 5](#) for manufacturing locations.

#### 4.2 Materials:

**4.2.1 EPS:** The insulation used in the Emmedue wall, floor and roof panels is expanded polystyrene (EPS) foam plastic boards manufactured from EPS beads recognized in ICC-ES [ESR-1798](#). The EPS is Type I EPS with a minimum density of 14.4 kg/m<sup>3</sup>, a flame-spread index of 25 or less and a smoke-developed index of 450 or less when tested in accordance with ASTM E84 at a 102 mm thickness and a 16.0 kg/m<sup>3</sup> maximum density.

**4.2.2 Reinforcement:** Deformed steel reinforcement bars must have a minimum yield stress of 420 Mpa (60 ksi) and comply with SBC 304-CR Section 20.2.1.3. Welded plain wire reinforcement must comply with SBC 304-CR Section 20.2.1.7. The wire used in the fabrication of the welded wire reinforcement is 2.5 mm diameter galvanized wire mesh spaced at 7.5 mm on center conforming to ASTM A1064 Grade 56 or ASTM A82. The steel transverse wire is 3 mm diameter galvanized wire conforming to ASTM A1064 Grade 70 or ASTM A82.

**4.2.3 Concrete:** Concrete must be normal-weight concrete, complying with the applicable code, having a maximum aggregate size of 16 mm, a minimum slump of 51 mm, and a minimum compressive strength of 20.0 MPa at 28 days. The concrete must comply with SBC 201-CR Chapter 19 and SBC 304-CR.

**4.2.4 Shotcrete:** Shotcrete must comply with SBC 201-CR Section 1908 and have a minimum specified compressive strength of 20.0 MPa. Aggregate size must not exceed 9.5 mm and conform to Gradation No. 1 of Table 2.1 of ACI 506R-90.

## 5.0 DESIGN AND INSTALLATION

### 5.1 Design:

Emmedue wall, floor and roof panels must be designed and constructed in accordance with SBC 201-CR Chapter 16. Design loads shall be determined from the load combinations in accordance with SBC 201-CR Section 1605. Loads, including but not limited to dead loads, live loads, wind loads and earthquake loads (for Seismic Design Categories A and B) must be determined in accordance with the applicable section under SBC 201-CR Chapters 16. The design loads for walls must not exceed the allowable wall panel loads and allowable wall panel racking shear loads set forth in [Tables 1](#) and [2](#) of this report, respectively. The design loads for roof and floor panels must not exceed the allowable roof, floor panel loads and allowable roof, floor panel diaphragm shear loads set forth in [Tables 3](#) and [4](#) of this report, respectively.

For each project, plans, specifications, and structural calculations must be submitted to the building official for approval, and must show particular job details relating to design and construction. The calculations must be based on loads and loading conditions as required in the IBC.

To ensure structural integrity, the Emmedue system must be subjected to a structural analysis, prior to construction, conducted by registered design professionals trained and certified by Industrial Bearing Building Co. The structural analysis must be used to determine structural capacities for all portions of the Emmedue system.

### 5.2 Fire-resistance-rated Assemblies:

#### 5.2.1 Two-Hour fire-resistance rating – Wall panels:

When tested in accordance with ASTM E119, wall panels constructed with up to an effective total thickness of 150 mm, consisting of EPS board cores with welded woven steel on each face where each panel is covered with a minimum thickness of 35 mm shotcrete on each face, have a two-hour fire resistance rating. The maximum allowable axial compressive load is 98 kN/m, exclusive of the weight of the wall panel. See [Figure 9](#) for wall details.

#### 5.2.2 One-Hour fire-resistance rating – Floor – roof panels:

Floor-roof panels with a minimum concrete thickness of 25 mm on the underside and 51 mm on the topside have a one-hour fire-resistance rating when tested in accordance with ASTM E119. The superimposed load shall not exceed 48.8 kg/m<sup>2</sup>.

#### 5.2.3 Fireblocking:

For applications on buildings of any height, floor-to-wall intersections must be fireblocked in accordance with the applicable code to prevent the passage of flame, smoke and hot gases from one story to another. The foam plastic insulation must not be continuous from one story to another.

### 5.3 Installation:

Foundation walls, footings, and other supporting structures receiving the Emmedue panels must be level and free of dirt and loose material. Emmedue panels are to be anchored to the foundation or supporting structure by means of reinforcing bars, installed as shown on the plans.

The Emmedue panels are aligned and held in place in accordance with the plans and manufacturer's installation instructions. Additional welded wire reinforcement is applied to corners and joints as shown on plans, then shotcrete complying with Section 3.2.4 of this report is applied to the welded wire reinforcement. The shotcrete must be applied to the outside and inside of the wall panels and to the underside of the floor-roof panels to the thickness shown on the plans. The exterior and interior concrete must be applied by the shotcrete process, using either the "dry" or "wet" process in accordance with the provisions of the Guide to Shotcrete (ACI 506R-90) and the Specification for Shotcrete (ACI 506.2-95). Shotcrete application must comply with SBC 201-CR Section 1908.

The shotcrete cover over the wall panel welded wire reinforcement must not be less than 25 mm in thickness, with a minus tolerance of 6 mm.

### 5.4 Special Inspection:

Special inspection of poured concrete or shotcrete construction, as applicable, must be in accordance with [Table 6](#) of this report and its referenced sections.

## 6.0 CONDITIONS OF USE:

The Emmedue wall, floor and roof panels described in this report comply with, or are suitable alternatives to what is specified in, those codes listed in Section 1.0 of this report, subject to the following conditions:

- 6.1 Installation complies with this report, the manufacturer's published installation instructions and the applicable code. In the event of a conflict between the manufacturer's published installation instructions and this report, this report governs.
- 6.2 For exterior use, wall panels must be installed with a code-complying weather-resistance exterior wall covering in accordance with Section 1403 of SBC 201-CR. Roof panels must be installed with a code-complying roof covering system in accordance with Section 1503 of SBC 201-CR.
- 6.3 The structural concrete wall systems recognized in this evaluation report, when used as seismic force-resisting systems, must be limited to Seismic Design Category A or B under the SBC 201-CR and SBC 304-CR.
- 6.4 Installation of elements requiring special inspection under the SBC 201-CR must comply with Section 4.4 of this report.
- 6.5 The panels are manufactured under a quality control program with inspections by ICC-ES.

## 7.0 EVIDENCE SUBMITTED

Evaluation based on data in accordance with the [ICC-ES Acceptance Criteria for Concrete Floor, Roof, and Wall Systems and Concrete Masonry Wall Systems \(AC15\)](#), dated February 2010, (Editorially revised March 2021).

## 8.0 IDENTIFICATION

- 8.1 The ICC-ES mark of conformity, electronic labeling, or the evaluation report number (ICC-ES ESR-5184) along with the name, registered trademark, or registered logo of the report holder and/or listee must be included in the product.
- 8.2 In addition, the Emmedue panels are labeled with the Industrial Bearing Building Co. (IBBCO) name, address, and manufacturing address.
- 8.3 The report holder's contact information is the following:  
**INDUSTRIAL BEARING BUILDING CO. (IBBCO)**  
**KING FAHD BRANCH ROAD – AL-SAHAFI DISTRICT**  
**POST OFFICE BOX RIYADH 13321-2256**  
**KINGDOM OF SAUDI ARABIA**  
**(920) 003-x089**  
[www.ibbco.com.sa](http://www.ibbco.com.sa)
- 8.4 The additional listee's contact information is the following:  
**ASALEEB ALIAN INDUSTRIES CO.**  
**4306 SUDAIR INDUSTRIES CITY**  
**TUMAIR 15336-6709**  
**KINGDOM OF SAUDI ARABIA**

**DALATAMEER INTERNATIONAL CO.**  
**JIZAN – CITY INDUSTRIAL ZONE 2797-7513**  
**P.O. BOX 84632**  
**KINGDOM OF SAUDI ARABIA**

**INNOVATIVE INTEGRATED INDUSTRIES**  
**3106 AL RAWDAH DISTRICT**  
**P.O. BOX 13211B**  
**RIYADH**  
**KINGDOM OF SAUDI ARABIA**

**TABLE 1—ALLOWABLE WALL PANEL LOADS**

TYPE OF LOADING	TYPE OF PANEL	PANEL HEIGHT (m)	AXIAL COMPRESSIVE LOADS (N/m)	TRANSVERSE LOADS (Pa)
Axial Compression	PSM80	2.43	113103	---
	PSM80	3.04	113978	---
	PSM80	3.65	115000	---
	PSM80	4.26	115876	---
Transverse for Deflection Limit L / 120	PSM80	2.43	---	10677
	PSM80	3.04	---	8475
	PSM80	3.65	---	6272
	PSM80	4.26	---	4118
Transverse for Deflection Limit L / 180	PSM80	2.43	---	9097
	PSM80	3.04	---	7326
	PSM80	3.65	---	5506
	PSM80	4.26	---	3735
Transverse for Deflection Limit L / 240	PSM80	2.43	---	8283
	PSM80	3.04	---	6703
	PSM80	3.65	---	5123
	PSM80	4.26	---	3543
Transverse for Deflection Limit L / 360	PSM80	2.43	---	5746
	PSM80	3.04	---	4932
	PSM80	3.65	---	4166
	PSM80	4.26	---	3400
Combined Axial and Transverse for Deflection Limit L / 120	PSM80	2.43	160533	8523
	PSM80	3.04	163159	6847
	PSM80	3.65	165641	5123
	PSM80	4.26	168268	3400
Combined Axial and Transverse for Deflection Limit L / 180	PSM80	2.43	160533	6224
	PSM80	3.04	163159	5075
	PSM80	3.65	165641	3926
	PSM80	4.26	168268	2729
Combined Axial and Transverse for Deflection Limit L / 240	PSM80	2.43	160533	5075
	PSM80	3.04	163159	4166
	PSM80	3.65	165641	3304
	PSM80	4.26	168268	2394
Combined Axial and Transverse for Deflection Limit L / 360	PSM80	2.43	160533	3926
	PSM80	3.04	163159	3304
	PSM80	3.65	165641	2681
	PSM80	4.26	168268	2107

**TABLE 2—ALLOWABLE WALL PANEL RACKING SHEAR LOADS**

TYPE OF LOADING	TYPE OF PANEL	PANEL HEIGHT (m)	RACKING SHEAR LOAD (N/m)	DEFLECTION (mm)
Racking Shear	PSM80	2.43	11237	1.52
	PSM80	3.04	12259	4.06
	PSM80	3.65	13280	6.35
	PSM80	4.26	14302	8.89

**TABLE 3—ALLOWABLE ROOF, FLOOR PANEL LOADS**

TYPE OF LOADING	TYPE OF PANEL	SPAN (m)	AXIAL COMPRESSIVE LOADS (N/m)	TRANSVERSE LOADS (Pa)
Transverse for Deflection Limit L /120	PSS80	2.43	---	14556
	PSS80	3.65	---	5698
	PSS150	2.43	---	16519
	PSS150	3.65	---	6464
Transverse I for Deflection Limit L /180	PSS80	2.43	---	12162
	PSS80	3.65	---	4836
	PSS150	2.43	---	13120
	PSS150	3.65	---	5267
Transverse for Deflection Limit L /240	PSS80	2.43	---	10965
	PSS80	3.65	---	4357
	PSS150	2.43	---	11396
	PSS150	3.65	---	4692
Transverse for Deflection Limit L /360	PSS80	2.43	---	9720
	PSS80	3.65	---	3926
	PSS150	2.43	---	9672
	PSS150	3.65	---	4070

**TABLE 4—ALLOWABLE ROOF, FLOOR PANEL DIAPHRAGM SHEAR LOAD**

TYPE OF LOAD	TYPE OF PANEL	SPAN (m)	DIAPHRAGM SHEAR LOAD (N/m)	DEFLECTION AT ALLOWABLE SHEAR LOAD (mm)
Diaphragm Shear	PSS80	2.43	6275	4.32

**TABLE 5—MANUFACTURING LOCATIONS**

industrial Bearing Building Co. (IBBCO) Riyadh Kingdom of Saudi Arabia	Asaleeb Alian Industries Co. Tumair Kingdom of Saudi Arabia	Innovative Integrated Industries Riyadh Kingdom of Saudi Arabia
--	---	---

**TABLE 6—REQUIRED SPECIAL INSPECTIONS AND TESTS OF CONCRETE CONSTRUCTION<sup>1, 2</sup>**

TYPE	CONTINUOUS SPECIAL INSPECTION	PERIODIC SPECIAL INSPECTION	REFERENCED STANDARD
1. Inspect reinforcement and verify placement.	-	X	SBC 304: Ch. 20, 25.2, 25.3, 26.6.1 through 26.6.4
2. Reinforcing bar welding: (a) Verify weldability of reinforcing bars other than ASTM A706; (b) Inspect single-pass fillet welds, maximum 8 mm; and (c) All other welds.	- - X	X X -	AWS D1.4 SBC 304: 26.6.4
3. Inspect anchors cast in concrete.	-	X	SBC 304: 17.8.2
4. Inspect anchors post-installed in hardened concrete members (a) Adhesive anchors installed in horizontally or upwardly inclined orientations to resist sustained tension loads. (b) Mechanical anchors and adhesive anchors not defined in 4a	X -	- X	SBC 304: 17.8.2.4 SBC 304: 17.1.2, 17.8.1 and 17.8.2
5. Verify use of required design mix.	-	X	SBC 304: Ch. 19, 26.4.3, 26.4.4
6. Prior to concrete placement, fabricate specimens for strength tests, perform slump and air content tests, and determine the temperature of the concrete.	X	-	ASTM C172 ASTM C31 SBC 304: 26.12
7. Inspect concrete to verify placement and for proper application techniques.	X	-	SBC 304: 26.5
8. Inspect curing and verify maintenance of specified curing temperature and techniques.	-	X	SBC 304: 26.5.3 through 26.5.5
9. Inspect formwork for shape, location and dimensions of the concrete member being formed.	-	X	SBC 304: 26.11
10. Inspect shotcrete placement for proper application techniques, materials, and testing.	X	-	SBC 201: 1908

<sup>1</sup>Table 6 is modified from SBC 201-CR Table 1705.3.

<sup>2</sup>Applicable inspections are to be determined by the registered design professional.

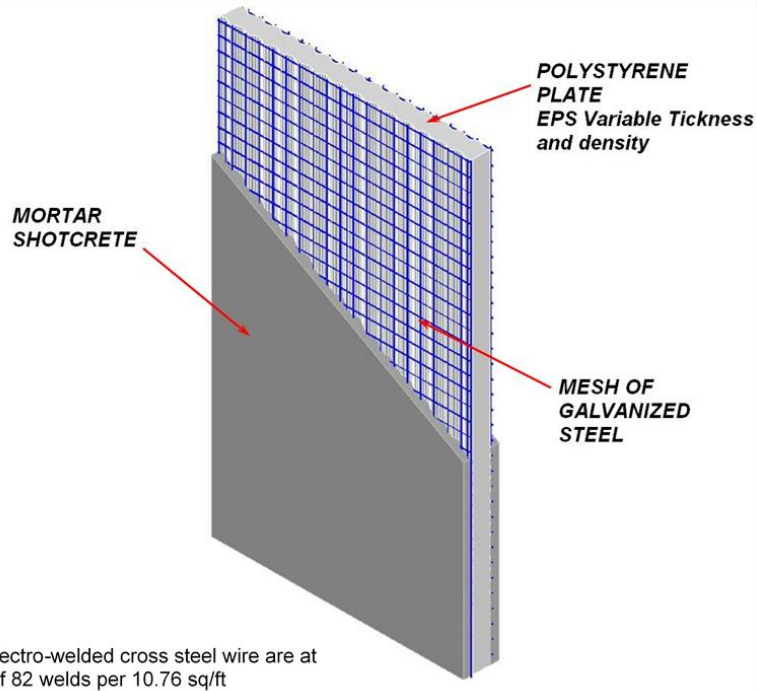

GENERAL DETAILS

**FIGURE 1 – TYPICAL WALL CONSTRUCTION**

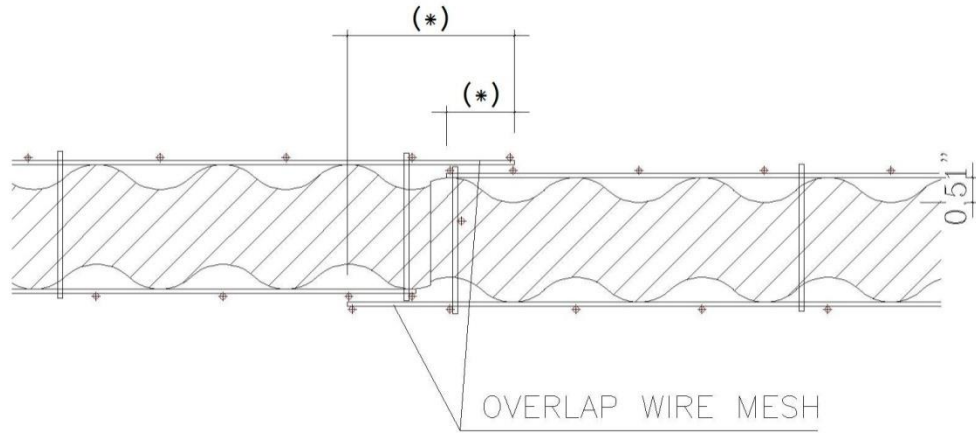

Note: (\*) to be design by engineer of records

FIGURE 2 – TYPICAL PANEL TO PANEL CONNECTION/JOINT DETAIL

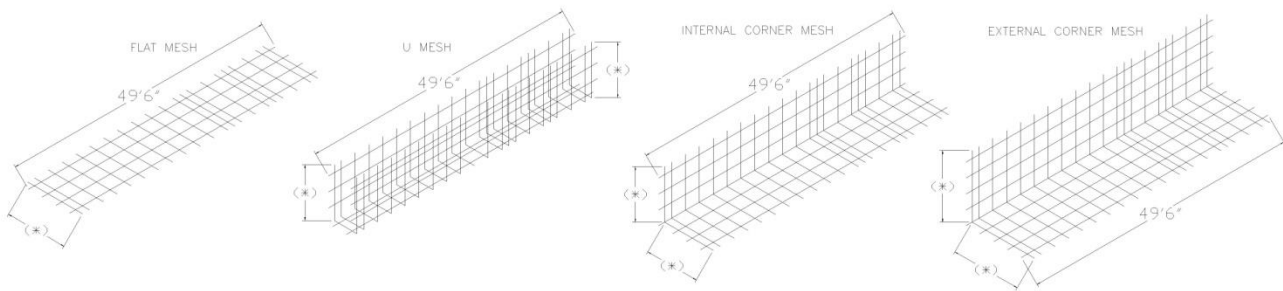

Note: (\*) to be design by engineer of records

FIGURE 3 — TYPICAL TYPES OF MESH USED FOR REINFORCEMENT/CONNECTION DETAIL



TYPICAL TYPES OF MESH USED FOR REINFORCEMENT/CONNECTION

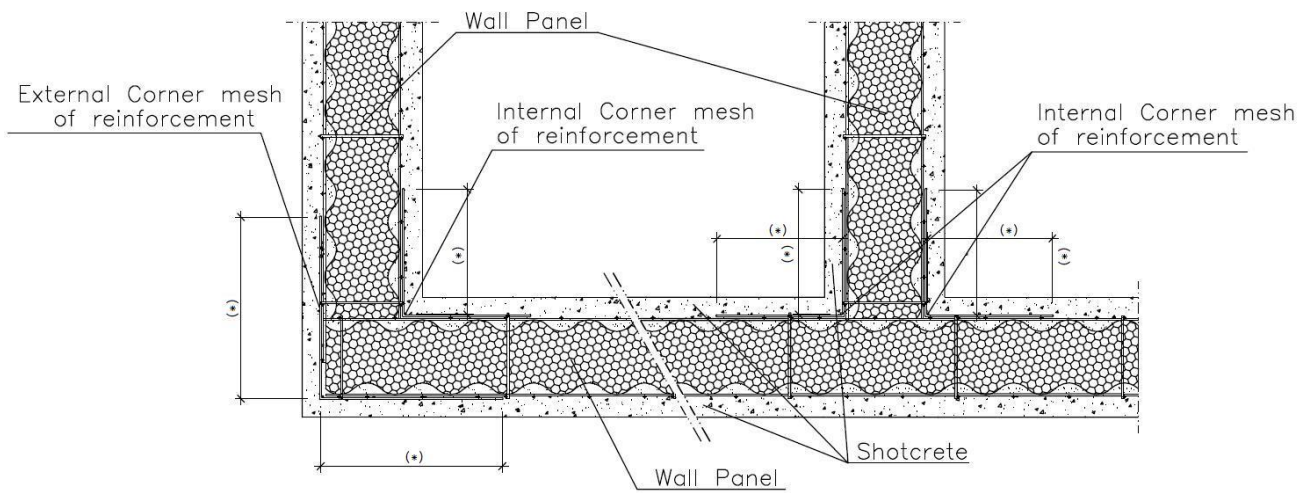
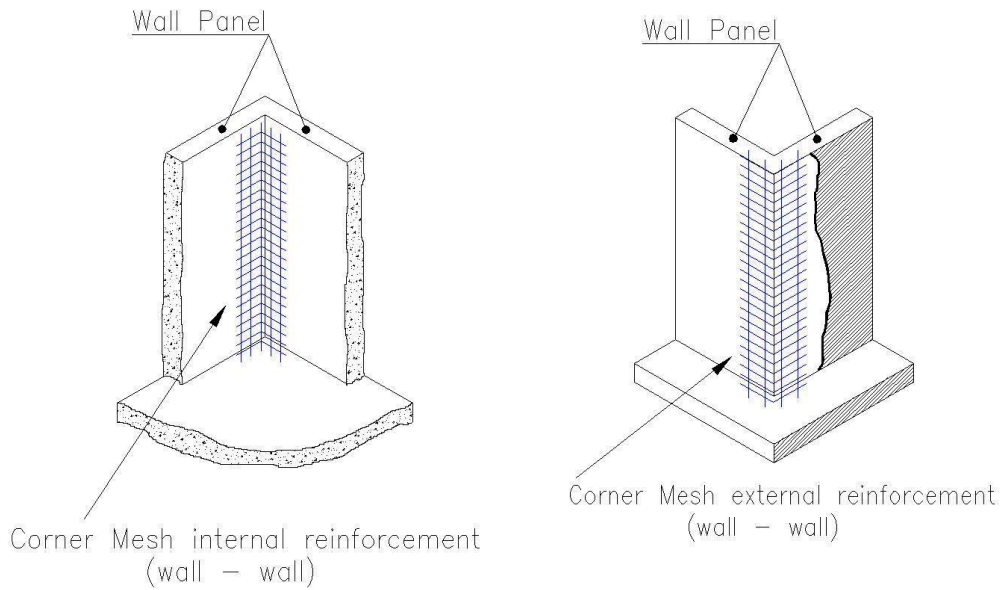

Note: (\*) to be designed by engineer of records

FIGURE 4—TYPICAL WALL PANEL TO WALL PANEL CORNER CONNECTION DETAIL

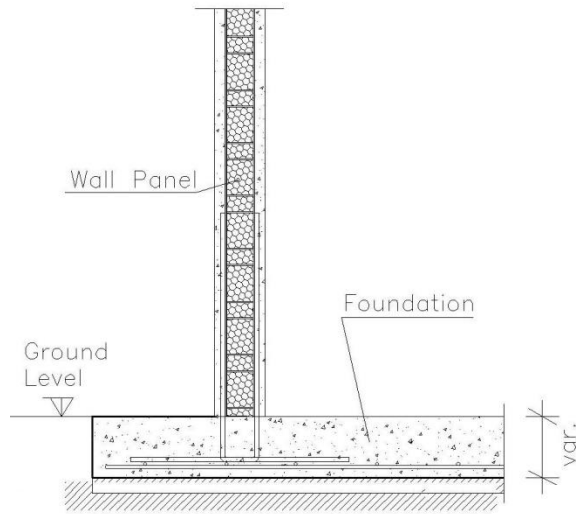

FIGURE 5—TYPICAL WALL PANEL TO FOUNDATION CONNECTION DETAIL

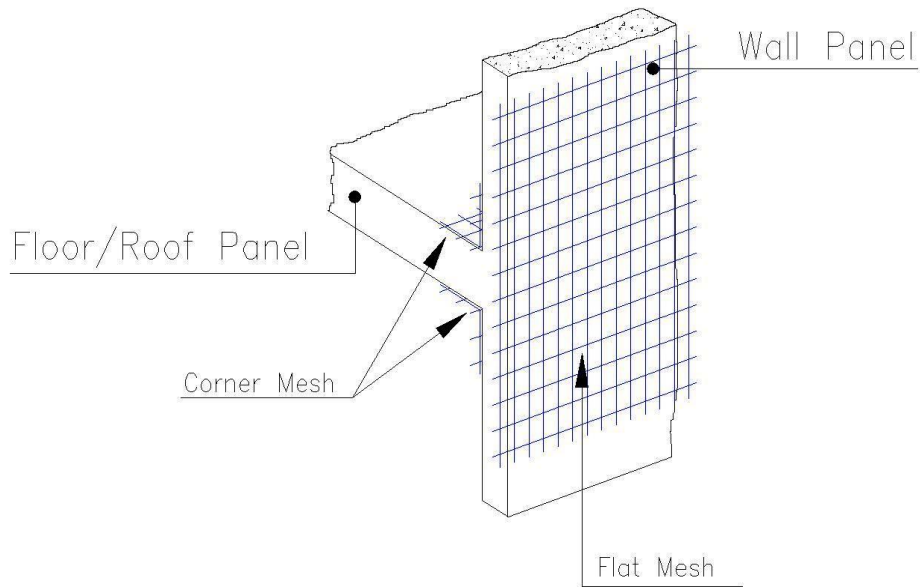
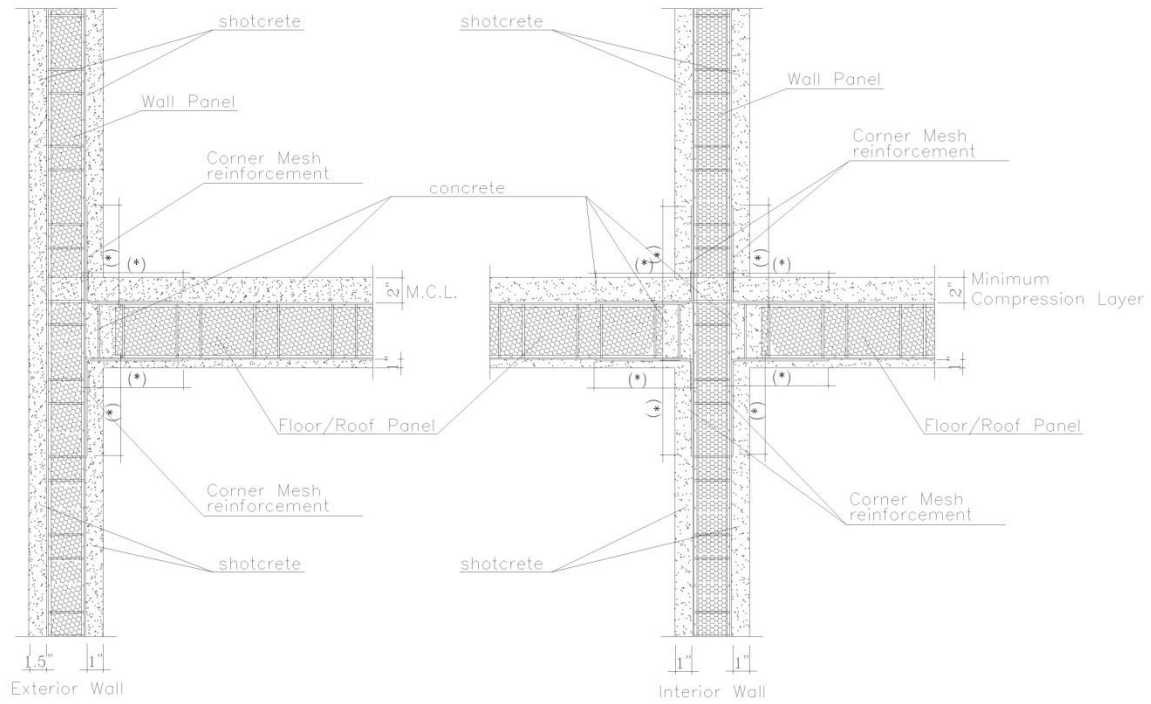

FIGURE 6—TYPICAL EXTERIOR WALL PANEL TO FLOOR/ROOF PANEL MESH DETAIL

WALL PANEL TO FLOOR/ROOF PANEL CONNECTION



Note: (\*) to be designed by engineer of records

FIGURE 7: TYPICAL WALL PANEL TO FLOOR/ROOF PANEL CONNECTION DETAIL

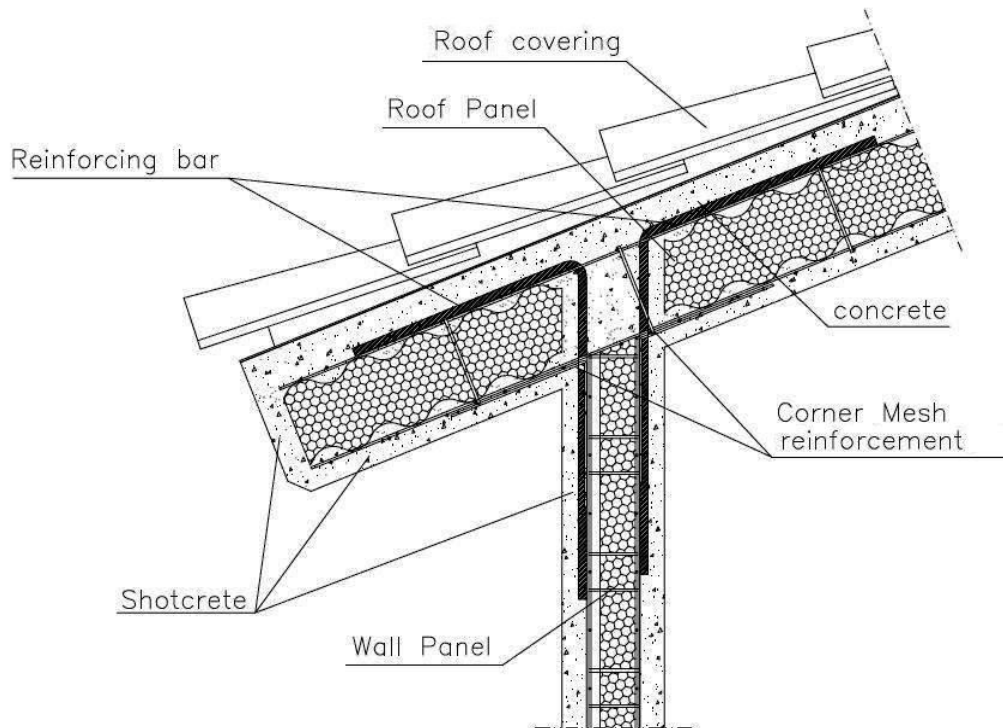
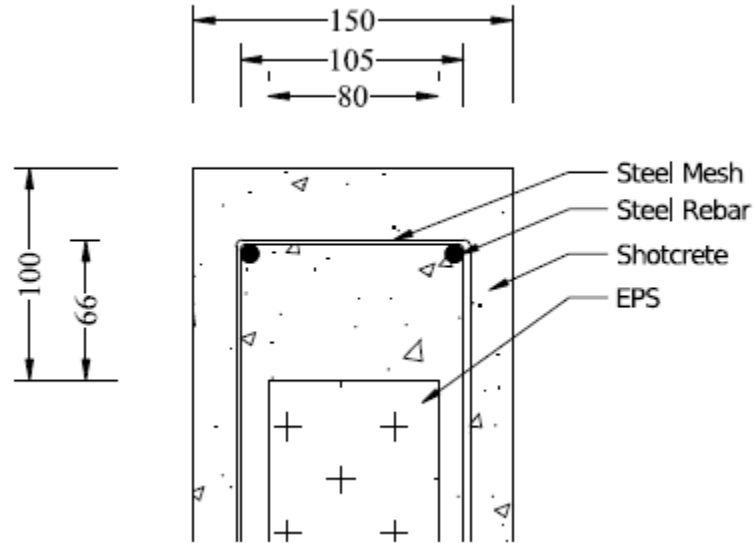
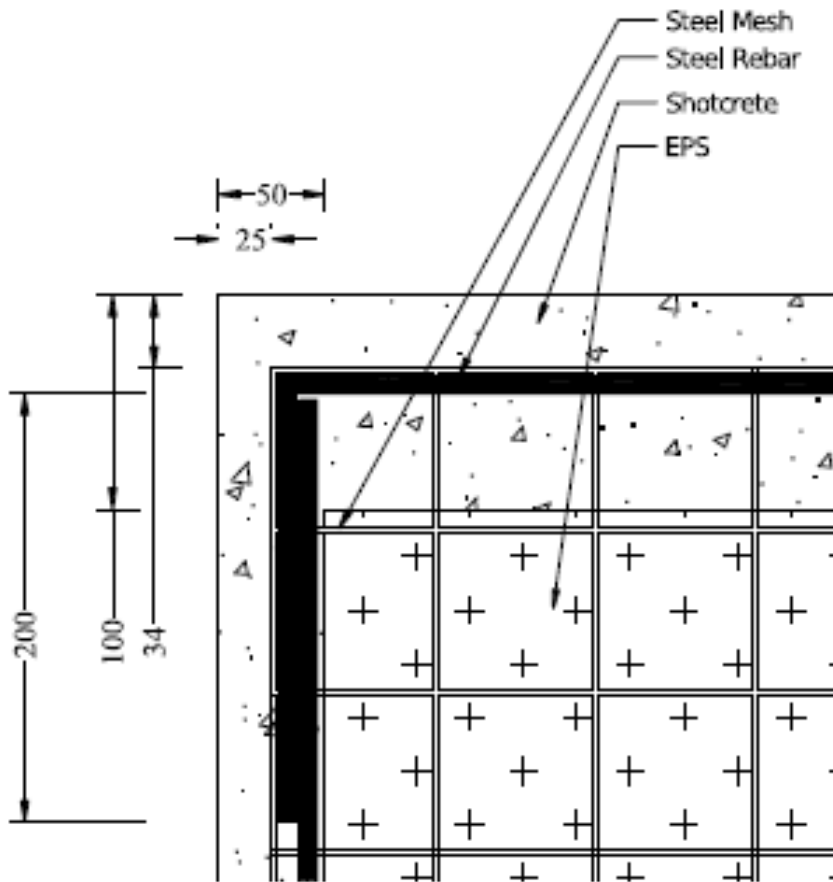

FIGURE 8—TYPICAL WALL PANEL TO ROOF PANEL CONNECTION DETAIL



CROSS SECTION SIDE VIEW DETAIL (MEASUREMENT IN MILLIMETERS)



CROSS SECTION FRONT VIEW DETAIL (MEASUREMENT IN MILLIMETERS)

FIGURE 9—DETAILS OF WALL PANEL – ASTM E119 2-HR FIRE-RESISTANCE RATED WALL ASSEMBLY