

ICC-ES Evaluation Report

ESR-4914

Reissued June 2024

Subject to renewal June 2025

ICC-ES Evaluation Reports are not to be construed as representing aesthetics or any other attributes not specifically addressed, nor are they to be construed as an endorsement of the subject of the report or a recommendation for its use. There is no warranty by ICC Evaluation Service, LLC, express or implied, as to any finding or other matter in this report, or as to any product covered by the report.

Copyright © 2024 ICC Evaluation Service, LLC. All rights reserved.

<p>DIVISION: 31 00 00— EARTHWORK</p> <p>Section: 31 63 00— Bored Piles</p>	<p>REPORT HOLDER: TITAN PRODUCTS TN LLC.</p>	<p>EVALUATION SUBJECT: TITAN SP-90 and SP-110 FOUNDATION SYSTEMS</p>	
--	--	--	---

1.0 EVALUATION SCOPE

Compliance with the following codes:

- 2021, 2018, 2015 and 2012 [International Building Code® \(IBC\)](#)
- 2021, 2018, 2015 and 2012 [International Residential Code® \(IRC\)](#)

Property evaluated:

- Structural

2.0 USES

The Titan Foundation Systems are used as support for structures to recover lost elevations and to provide uniform supplemental support to foundations. The Titan Foundation Systems provides structural lift to help stop settlement of the structure. These products are used on residential, commercial, and industrial foundations. The Titan Foundation Systems can be installed in either interior or exterior applications.

When Titan Foundation Systems are installed under the IRC, an engineered design is required in accordance with IRC Section R301.1.3.

3.0 DESCRIPTION

3.1 General:

The Titan SP-90 and SP-110 Foundation Systems are push pile systems consisting of an under footing self-standing bracket body that attaches to an existing footing, a guide sleeve that passes through the bracket body, a piling tube shaft that is hydraulically advanced to firm bearing strata, and the lifting threaded rods and nuts passing through a pile cap plate to hold the imposed load.

3.2 Components and Materials:

3.2.1 Titan Model SP-90

3.2.1.1 Pile Guide Sleeve: The pile guide sleeve is fabricated from steel tubing with 3½ inches (89 mm) outside diameter and a nominal 0.165-in (4.2 mm) wall thickness conforming to ASTM A500 and a minimum yield strength of 50 ksi (345 MPa) fabricated in 41-in. (1041 mm) sections. See [Figure 1](#).

3.2.1.2 Pile Starter and Extension Section: The pile starter and extension section are fabricated from steel tubing with 27⁄8 inches (73 mm) outside diameter and a nominal 0.165-in (4.2 mm) wall thickness conforming to ASTM A500 and a minimum yield strength of 50 ksi (345 MPa) fabricated in 42-in. (1066 mm) sections. See [Figure 1](#).

3.2.1.3 Connector Sleeve: The connector sleeve is fabricated from steel tubing with 2½ inches (64 mm) outside diameter and a nominal 0.155-in (3.9 mm) wall thickness conforming to ASTM A500 and a minimum yield strength of 50 ksi (345 MPa) fabricated in 6-in (152 mm) sections. See [Figure 1](#).

3.2.1.4 Bracket: A robotically welded steel assembly consisting of ¾-in (9.5 mm) thick parts cut from ASTM A36 steel plate. See [Figure 2](#).

3.2.1.5 Pile Cap Plate: Pile cap plate is 1-in (25 mm) thick, 3½-inches (89 mm) wide by 9 inches (229 mm) long steel that conforms to ASTM A36 steel.

3.2.1.6 Lifting Rods: Consist of two (2) ¾-inch (19 mm) by 12-inches (305 mm) long threaded rods that conform to ASTM A193 Grade B7 steel, using (4) ¾-inch (19 mm) ASTM A194-14, Grade 2H heavy hex nuts.

3.2.1.7 Footer Bearing Plate: Footer bearing plate is ¾-inch (9.5 mm) thick, 9¼ inches (235 mm) wide by 7¼ inches (184 mm) long that conforms to ASTM A36 steel.

3.2.2 Titan Model SP-110

3.2.2.1 Pile Guide Sleeve: The pile guide sleeve is fabricated from steel tubing with 4 inches (102 mm) outside diameter and a nominal 0.188-in (4.8 mm) wall thickness conforming to ASTM A500 and a minimum yield strength of 50 ksi (345 MPa) fabricated in 41-in. (1041 mm) sections. See [Figure 1](#).

3.2.2.2 Pile Starter and Extension Section: The pile starter and extension section are fabricated from steel tubing with 3½ inches (89 mm) outside diameter and a nominal 0.165-in (4.2 mm) wall thickness conforming to ASTM A500 and a minimum yield strength of 50 ksi (345 MPa) fabricated in 42-in (1066 mm) sections. See [Figure 1](#).

3.2.2.3 Connector Sleeve: The connector sleeve is fabricated from steel tubing with 3⅛ inches (79 mm) outside diameter and a nominal 0.188-in (4.8 mm) wall thickness conforming to ASTM A500 and a minimum yield strength of 50 ksi (345 MPa) fabricated in 6-in (152 mm) sections. See [Figure 1](#).

3.2.2.4 Bracket: A robotically welded steel assembly consisting of ½-in (12 mm) thick parts cut from ASTM A36 steel plate. See [Figure 2](#).

3.2.2.5 Pile Cap Plate: Pile cap plate is 1½ inches (38 mm) thick, 4 inches (102 mm) wide by 9 inches long (229 mm) steel that conforms to ASTM A36 steel.

3.2.2.6 Lifting Rods: Consist of two (2) 7/8-in (22 mm) by 18 inches (457 mm) long threaded rods that conform to ASTM A193, Grade B7 steel using (4) 7/8-in (22 mm) ASTM A194-14, Grade 2H heavy hex nuts.

3.2.2.7 Footer Bearing Plate: Footer bearing plate is ½-in (12 mm) thick, 10 inches (254 mm) wide by 8 inches (203 mm) long that conforms to ASTM A36 steel.

3.2.2.8 Optional Pile Section: Optional pile section is fabricated from steel tubing with 4 inches (102 mm) outside diameter and a nominal 0.210-in (5.3 mm) wall thickness conforming to ASTM A500, and a minimum yield strength of 50 ksi (345 MPa) fabricated in 42-in (1066 mm) sections. It can be used without a guide sleeve.

4.0 DESIGN AND INSTALLATION

4.1 Design:

4.1.1 General: Engineering calculations (analysis and design) and drawings, prepared by a registered design professional, must be submitted to and be subjected to the approval of the code official for each project, and must be based on accepted engineering principles, as described in IBC Section 1604.4, and must conform to 2021, 2018, 2015 and 2012 IBC Section 1810. The design method for the steel components is Allowable Strength Design (ASD), described in IBC Section 202 and AISC 360-16 Section B3.2 (AISC 360-10 Section B3.4 for the 2015 and 2012 IBC). The engineering analysis must address hydraulically driven foundation system performance related to structural and geotechnical requirements.

The structural analysis must consider all applicable internal forces (shears, bending moments and torsional moments, if applicable) due to applied loads, structural eccentricity and maximum span(s) between push pile systems. The minimum embedment depth for various loading conditions must be included based on the most stringent requirements of the following: engineering analysis, allowable capacities noted in this report, site-specific geotechnical investigation report, and site-specific load tests, if applicable.

A soil investigation report in accordance with this Section must be submitted for each project, when required by the authority having jurisdiction. The soil interaction capacity between the pile and the soil including the required safety factor and the soil effects of the hydraulically driven steel pile installation must be determined in accordance with the applicable code by a registered design professional. The maximum installation force and working capacity of the hydraulically driven steel pile system must be determined in accordance with Titan Products Installation Instructions and as recommended by the registered design professional. The allowable strengths (allowable capacities) of the steel components of the Titan Foundation Brackets are described in [Table 1](#).

4.1.2 Bracket Capacity: [Table 1](#) describes the allowable axial compression capacity of the Titan Foundation Brackets. The concrete foundation must be designed and justified to the satisfaction of the local code official with due consideration to the eccentricity of the applied loads, including reactions provided by the brackets, acting on the concrete foundation. Only localized limit states of the steel components to the piles have been evaluated in this evaluation report. Other limit states are outside the scope of this evaluation report and must be determined by the registered design professional. The effects of reduced lateral sliding resistance due to uplift from wind or seismic loads must be considered for each project.

4.1.3 Pile Shaft Capacity: The pile shaft capacity has not been evaluated and is outside the scope of this report. Capacity must be addressed by a registered design professional and is subject to approval by code official.

4.2 Installation:

The Titan Foundation Systems must be installed by Titan Products TN LLC. certified and trained installers. The Titan Foundation Systems must be installed in accordance with this section (Section 4.2), the site-specific approved construction documents (engineering plans and specifications), and the manufacturer's installation instructions.

1. A site survey is necessary of the area where the piles are going to be driven to locate any possible interference such as utilities, plumbing, electrical, or phone lines.
2. Small excavations are dug for each access point for the placement of the piles. Expose the footing or bottom of grade beam to a safe working width and at least 12 inches below the bottom of the footing or grade beam. The total space needed for the foundation is typically 3 feet square.
3. Mark all pile installation locations as shown on the plans or approved shop drawings.
4. Follow OSHA requirements at all times. Workers shall not enter excavation if the stability of the soil is questionable.
5. The hydraulic drive cylinder, hoses, gages and fittings shall be verified to be in proper working condition. Do not exceed the maximum pressure capacity of the hydraulic drive cylinder per the manufacturer.
6. The vertical and bottom face of the footing shall be smooth and at right angles of each other for the mounting of the pile footing bracket. The surfaces in contact with the support bracket must be free of all dirt, debris and loose concrete so as to provide firm bearing surfaces for the pile footing bracket.
7. Spread footing, if applicable, must be notched for the pile bracket seat to be mounted directly under the foundation/basement (load bearing) wall. If any reinforcing bar becomes exposed during the notching process consult with Engineer before removing or cutting steel reinforcing.
8. Install the pile footing bracket beneath the footing or grade beam. Check for alignment and full bearing between the pile bracket and the bottom of the footing. Verify contact between the back of the bracket and the vertical face of the foundation which may be attached to the footing or grade beam with (2) concrete anchors.
9. Insert starter pile section and pile guide sleeve through the pile bracket. Advance the pile section together not exceeding a one (1) degree angle from vertical.
10. Pile sections shall be continuously added as required to advance the pile through unstable soils until the design load, design depth, or a suitable bearing stratum is reached. The final driving load on the pile shall be held to check for pile creep.
11. Piles shall be installed individually to maximize the resistance of the structure as a reaction force to install each pile.

12. Cut the last pile section off approximately four (4) inches above the pile bracket and place pile cap plate on top of the pile securing it with all-thread bolts to the pile footing bracket.
13. Once lifting of the structure or proof loading of the pile is completed, secure the pile cap plate to the pile footing bracket with the threaded fastener nuts and remove hydraulics

4.3 Special Inspection:

Special inspection in accordance with 2021, 2018, 2015 and 2012 IBC Section 1705.7, is required for installation of the Titan Foundation Systems, except as indicated in Section 1704.2 of the IBC. Items to be recorded and confirmed by the special inspector must include, but are not limited to, the following:

1. Verification of the product manufacturer, and the manufacturer's certification of installers.
2. Product identification, including lead sections, extension sections, brackets, bolts and nuts, as specified in the construction documents and this evaluation report.
3. Installation procedures anticipated and actual piling depth.
4. Tip elevations, the installation pressure and final depth of the driven foundation system.
5. Inclination and position/location of hydraulically driven steel piles.
6. Compliance of the installation with the approved construction documents and this evaluation report.

5.0 CONDITIONS OF USE:

The Titan SP-90 & SP-110 Foundation Systems described in this report comply with, or are a suitable alternative to what is specified in, those codes listed in Section 1.0 of this report, subject to the following conditions:

- 5.1 The Titan Foundation Systems are manufactured, identified and installed in accordance with this report, the approved construction documents and the manufacturer's published installation instructions. In the event of a conflict between this report, the approved construction documents and the manufacturer's published installation instructions, the most restrictive governs.
- 5.2 This evaluation report does not address seismic loading for this system, existing footing suitability or attachment requirements to existing footings.
- 5.3 Installation of the hydraulically driven pile systems must be limited to support of uncracked normal-weight concrete, as determined in accordance with the applicable code.
- 5.4 Brackets must be used only to support structures that are laterally braced as defined in 2021, 2018, 2015 and 2012 IBC Section 1810.2.2.
- 5.5 Corrosion resistance and durability are outside the scope of this evaluation report.
- 5.6 The Titan Foundation Brackets are rated for compression loading only. Lateral and uplift loading from wind and seismic shall be carried by the existing shallow foundation and verified by a registered design professional.
- 5.7 Each pile system that is installed, is load tested against the weight of the structure to ensure that the system can withstand a load greater than needed to restore the structure. A registered design professional shall provide the test load safety factor requirements based upon the site specific soil conditions.
- 5.8 Adjacent piles shall not be advanced simultaneously.
- 5.9 All the excavated soil at each pile location shall be replaced and compacted after the piles are proof load tested
- 5.10 The adequacy of the concrete structures that are connected to the Titan Foundation Systems must be verified by a registered design professional, in accordance with applicable code provisions, such as Chapter 13 of ACI 318-19 under 2021 IBC and of ACI 318-14 under the 2018 and 2015 IBC (Chapter 15 of ACI 318 under the 2012 IBC) and Chapter 18 of IBC, and subject to the approval of the code official.
- 5.11 The hydraulically driven piles must be installed vertically into the ground with a maximum allowable angle of inclination of 1 degree.
- 5.12 Special inspection is provided in accordance with Section 4.3 of this report.
- 5.13 Engineering calculations and drawings as described in Section 1604.4 of the IBC and comply with the design and installation requirements of this evaluation report are to be prepared by a registered design professional. All of these documents are to be submitted and approved by the local code official.

- 5.14** Settlement of the hydraulically driven pile is outside the scope of this evaluation report and must be determined by a registered design professional as required in 2021, 2018, 2015 and 2012 IBC Section 1810.2.3.
- 5.15** The interaction between the hydraulically driven pile system and the soil is outside the scope of this report
- 5.16A** A copy of the manufacturer's published installation instructions shall be made available on the job site at the time of installation.
- 5.17** The Titan SP-90 & SP-110 Foundation Systems are manufactured under a quality control program with inspections monitored by the ICC-ES.

6.0 EVIDENCE SUBMITTED

- Bracket eccentric compression load tests in accordance with ASTM E72.
- Quality control documentation and installation instructions.

7.0 IDENTIFICATION

- 7.1** The ICC-ES mark of conformity, electronic labeling, or the evaluation report number (ICC-ES ESR-4914) along with the name, registered trademark, or registered logo of the report holder must be included in the product label.
- 7.2** In addition, the Titan SP-90 & SP-110 Foundation Systems are identified by a label bearing the Titan Products address, catalog number, batch number and load rating.
- 7.3** The report holder's contact information is the following:

TITAN PRODUCTS TN LLC.
2111 BOAT FACTORY ROAD
PLEASANT VIEW, TENNESSEE 37146
(615) 746-6876
www.titanproductsinc.com

TABLE 1 – TITAN FOUNDATION BRACKETS COMPRESSION LOAD RATINGS⁴

MODEL	PRODUCT DESIGNATION	PILING DIAMETER (inches)	ULTIMATE LOAD BRACKET (lbf) ^{1,2}	ALLOWABLE BRACKET CAPACITY (lbf) ³
Model SP-90	Foundation Bracket	2 ⁷ / ₈	91,900	45,950
Model SP-110	Foundation Bracket	3 ¹ / ₂	114,933	57,467

For SI: 1 inch = 25.4 mm, 1 kip (1000 lbf) = 4.48 kN.

1. Tested bracket capacities are based on steel failures only. Concrete capacity is outside the scope of this report.
2. Ultimate load is based on the average of (3) specimens.
3. Allowable capacities shall be utilized with Allowable Strength Design (ASD) loading. Safety Factor of 2 is applied to Ultimate Load.
4. The Titan Foundation Brackets capacity results reflect a 5-inches maximum unsupported pile guide sleeve length.

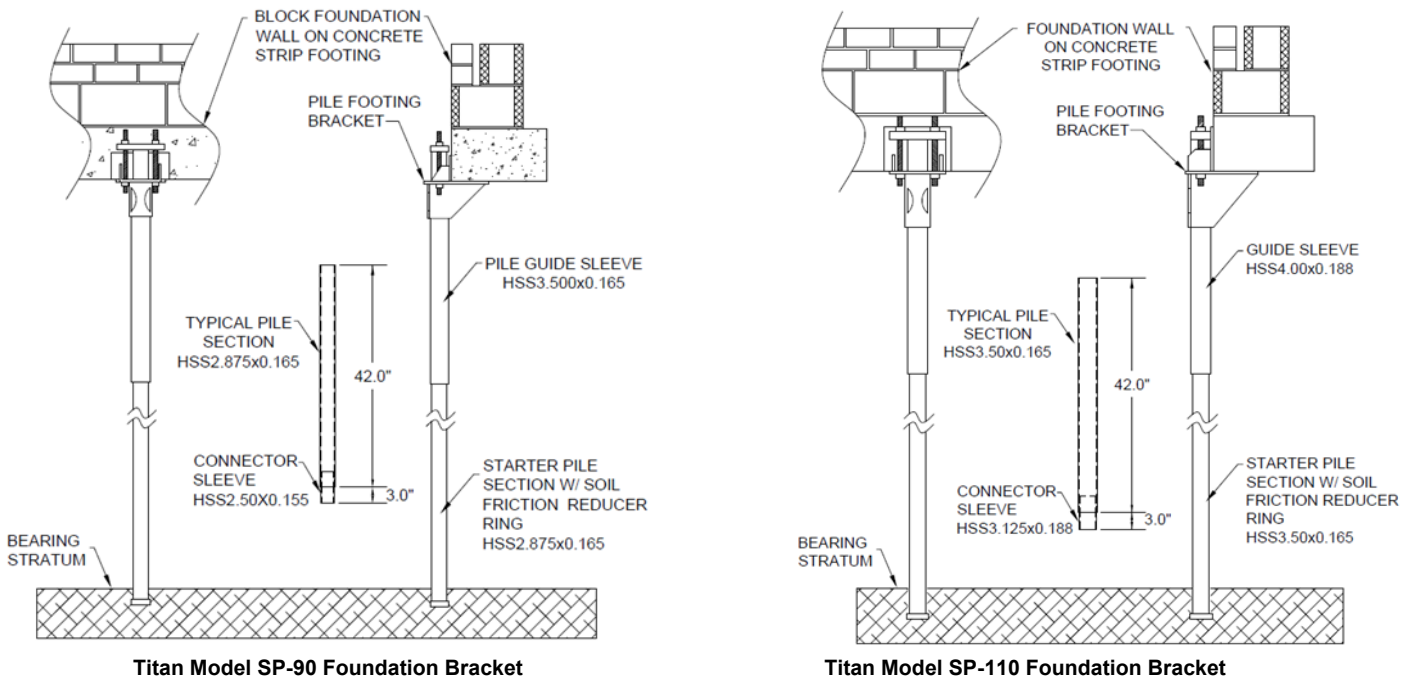
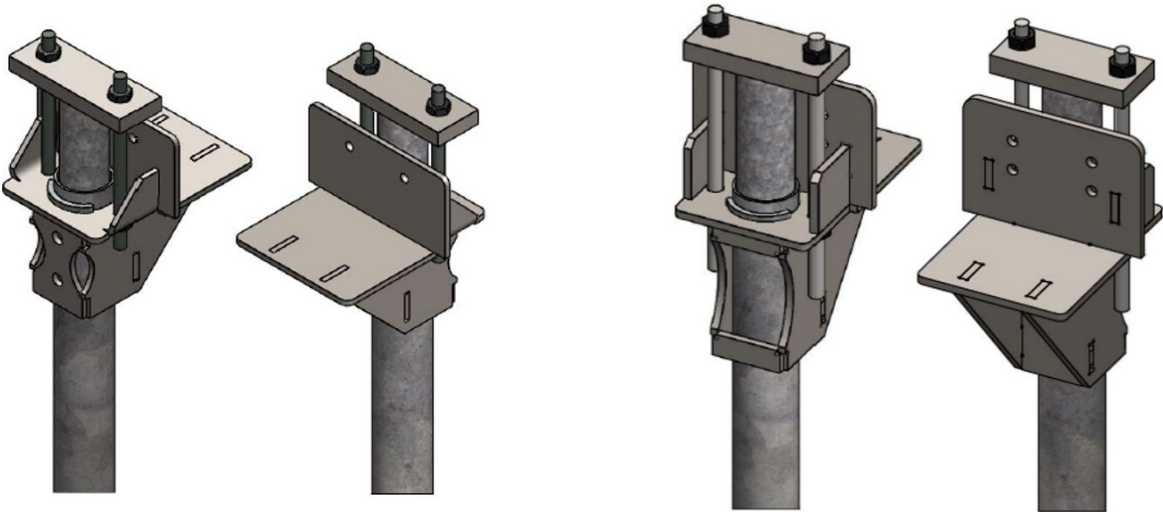

FIGURE 1 – TITAN FOUNDATION BRACKETS



SP-90 Bracket Assembly

SP-110 Bracket Assembly

FIGURE 2 – BRACKET ASSEMBLIES