

ICC-ES Evaluation Report

ESR-4913

Reissued September 2024

This report also contains:

- CBC Supplement

Subject to renewal September 2025

ICC-ES Evaluation Reports are not to be construed as representing aesthetics or any other attributes not specifically addressed, nor are they to be construed as an endorsement of the subject of the report or a recommendation for its use. There is no warranty by ICC Evaluation Service, LLC, express or implied, as to any finding or other matter in this report, or as to any product covered by the report.

Copyright © 2024 ICC Evaluation Service, LLC. All rights reserved.

<p>DIVISION: 21 00 00 - FIRE SUPPRESSION</p> <p>Section: 21 13 13—Wet-Pipe Sprinkler Systems</p>	<p>REPORT HOLDER:</p> <p>VICTAULIC COMPANY</p>	<p>EVALUATION SUBJECT:</p> <p>FIRELOCK™ SERIES FL-SA/WS WINDOW SPRINKLERS MODEL V2752 PENDENT SPRINKLER, MODEL V5648 CONCEALED PENDENT SPRINKLER</p>	
--	--	--	---

1.0 EVALUATION SCOPE

Compliance with the following code:

- 2021, 2018, 2015, 2012 and 2009 [International Building Code® \(IBC\)](#)
- 2013 *Abu Dhabi International Building Code (ADIBC)*†

†The ADIBC is based on the 2009 IBC. 2009 IBC code sections referenced in this report are the same sections in the ADIBC.

Property evaluated:

- Alternative to a fire-resistance-rated wall assembly

2.0 USES

The Firelock Series FL-SA/WS automatic special-purpose window sprinkler system consisting of Model V2752 pendent vertical sidewall sprinkler and/or Model V5648 concealed pendent vertical sidewall sprinkler are used in conjunction with a fixed glazed wall assembly to provide an alternative to a two-hour fire-resistance-rated nonload-bearing interior fire barrier assembly prescribed in IBC Section 707, fire partition assembly prescribed in IBC Section 708, or exterior wall assembly prescribed in IBC Section 705. The Model V2752 and Model V5648 sprinklers are recognized as a means to achieve a fire-resistance rating on fixed glazed wall assemblies in exterior fire-resistance-rated walls only when the horizontal fire separation distance is 10 feet (3048 mm) or greater.

3.0 DESCRIPTION

3.1 General:

The Model V2752 and Model V5648 window sprinklers are used as part of a wet-pipe fire suppression system to provide a two-hour fire-resistance rating to an interior nonload-bearing fire barrier, fire partition or exterior wall assembly consisting of fixed glazing as described in this report. When activated, the sprinklers are designed to wet the entire surface of the affected side of the fixed glazed openings in the fire barrier and exterior wall assembly in order to achieve the fire-resistance rating of the wall. For exterior glazed assemblies that are permitted to be rated only from the interior, the sprinklers must be located on the interior side of the glazing. For interior glazed assemblies, the sprinklers must be located on both sides of the assembly. The primary components of the fire-resistance rated assembly are as described in Section 3.2.

3.2 Model V2752 and Model V5648:

The Model V2752 and Model V5648 window sprinklers described in this report are quick-response sprinklers that activate to release water flow when they reach an ambient temperature of either 155°F or 200°F (68°C or 93°C). The sprinklers have a nominal K-factor of 5.6 gpm/psig^{1/2} (80 L/min/bar^{1/2}) and a thread size of 1/2 inch (12.7 mm).

The Model V2752 sprinkler is manufactured for pendent vertical sidewall orientation, as shown in [Figure 1](#), is designed to face the glazing of the fire barrier assembly in a vertical orientation.

The Model V5648 sprinkler is manufactured for concealed pendent vertical sidewall orientation, as shown in [Figure 2](#), is designed to face the glazing of the fire barrier assembly in a vertical orientation.

3.3 Glazed Fire Barrier Assembly:

The glazing used in the fire barrier must be nominally 1/4-inch-thick (6.4 mm) heat-strengthened or tempered glass complying with ASTM C1048 or Federal Specification DD-G-1403B, installed as a single pane or dual pane. The exposed glass component of the wall assembly must not exceed 13 feet (4 m) in height. There is no exposed width restriction for the horizontal span, except where necessary to comply with the requirements of IBC Sections 2403 and 2404.

All interfaces between the fixed glazed wall assembly and adjacent wall assemblies must include termination of the glazing within a window frame as described in this section. The glazing is held in place by a metallic frame with an elastomeric seal allowing for thermally initiated contraction and expansion. Unframed vertical joints between glazing panels are permitted provided that such joints are connected by butt-joints using silicon sealant between the individual panes or by noncombustible mullions. Intermediate horizontal mullions are not permitted as part of the fixed glazed wall assembly. The interface details and mounting method must be approved by the code official.

4.0 INSTALLATION

4.1 Sprinkler Orientation:

The Model V2752 pendent vertical sidewall sprinkler must be located 4 to 12 inches (102 to 305 mm) from the face of the glass and 2 to 4 inches (51 to 102 mm) down from the top of the noncombustible frame as shown in [Figure 5](#).

The Model V5648 concealed pendent vertical sidewall sprinkler must be located 6 to 12 inches (152 to 305 mm) from the face of the glass and even with the top of the exposed glass and up to a maximum of 4 inches (102 mm) above the top of the exposed glass as shown in [Figure 6](#).

Intermediate horizontal mullions are not permitted as part of the glass wall assembly. All combustible materials must be kept a minimum distance of 2 inches (51 mm) from the face of the glass. This can be accomplished by a 36-inch-high (914 mm) "pony wall". This "pony wall" is constructed using construction methods and materials as recognized in the applicable codes based on the building's type of construction. The "pony wall" must be constructed in a manner which meets the minimum required fire-resistance rating which is sought for the fixed glazed wall assembly. This "pony wall" construction must be approved by the code official. The evaluation of alternative methods other than the "pony wall" to maintain a minimum 2-inch (51 mm) clearance of combustibles from the face of the assembly is outside the scope of this report.

The maximum distance between the Model V2752 window sprinklers is 12 feet (3658 mm) on center and the minimum distance is 6 feet (1828 mm) on center, as shown in [Figure 3](#), except where the sprinklers are separated by a noncombustible vertical mullion located between sprinklers.

The maximum distance between the Model V5648 concealed window sprinkler is 12 feet (3658 mm) on center and the minimum distance is 6 feet (1828 mm) on center, as shown in [Figure 4](#), except where the sprinklers are separated by a noncombustible vertical mullion located between sprinklers. As an alternative when the Victaulic cold solder umbrella escutcheon is installed, the minimum distance may be 5 feet (1524 mm) on center, as shown in [Figure 4A](#).

The automatic water supply must have the capability to supply water to the assembly for a time not less than the rating of the assembly. The maximum fire-resistance rating recognized in this report is two hours.

4.2 Hydraulic Requirements

The code official must be consulted to determine the hydraulic requirements for each installation. Hydraulic calculations must show a maximum pressure of 175 psi (1207 kPa) on the vertical sidewall sprinklers and horizontal sidewall sprinklers separated by a noncombustible vertical mullion.

4.3 Interior Protection-Sprinklered Building:

The compartmented area that has the most hydraulically demanding window sprinklers must be identified. The most demanding 46.5 linear feet (14.2 m) of Model V2752 and Model V5648 window sprinklers is calculated based on $L=1.2 \sqrt{A}$, where A is system area of operation, and when A equals 1,500 square feet (139.4 m²), in accordance with NFPA 13 Light/Ordinary Hazard density curves.

If an area reduction for quick-response sprinklers is being utilized, the linear length of the calculated window sprinklers may be reduced to 36 linear feet (11 m) or greater, based on $L=1.2 \sqrt{A}$, where A is a minimum of 900 square feet (83.6 m²). If a single fire can be expected to cause operation of the Model V2752 and Model V5648 window sprinklers and sprinklers within the design area of a hydraulically calculated system, the water flow demand of the window sprinklers must be added to the water demand of the hydraulic calculations and must be balanced to the calculated area demand. If the window sprinklers are located in an area other than the hydraulic design area, the demand of the window sprinklers is not required to be added to the demand of the remote hydraulic design area; however, it is necessary to hydraulically prove that proper simultaneous operation of the Model V2752 and Model V5648 window sprinklers and the ceiling sprinklers adjacent to the Model V2752 and Model V5648 window sprinklers will occur.

5.0 CONDITIONS OF USE

The Victaulic Company Firelock Series FL-SA/WS automatic special-purpose window sprinkler Model V2752 and Model V5648 described in this report comply with, or are suitable alternatives to what is specified in, those codes listed in Section 1.0 of this report, subject to the following conditions:

- 5.1 The installation of the special-purpose sprinkler systems must be in accordance with the manufacturer's published installation instructions, this report and the applicable code. In the event of a conflict between this report and the manufacturer's published installation instructions, this report governs. A copy of the installation instructions, and this report must be available at all times on the jobsite during installation.
- 5.2 The design, with plans and details of the fixed glazed assembly with special-purpose sprinklers, must be submitted to the code official for approval. The design must be prepared by a registered design professional where required by the statutes of the jurisdiction in which the project is to be constructed.
- 5.3 When approved by the code official, the fixed glazed assembly described in this report, comprised of special-purpose sprinklers with fixed glazing having specific construction requirements, is intended to provide an alternative to a two-hour fire-resistance-rated nonload-bearing interior fire barrier assembly prescribed in IBC Section 707, a fire partition assembly described in IBC Section 708 or an exterior wall assembly prescribed in IBC Section 705. The registered design professional must provide the code official with documentation outlining the basis of compliance with the criteria specified by the IBC for a code modification in accordance with Section 104.10 or for an alternative method of construction in accordance with Section 104.11.
- 5.4 The assembly must not be used in locations that contain materials that present deflagration or detonation hazards.
- 5.5 Special-purpose fire sprinkler system piping must be designed, sized and installed in accordance with NFPA 13.
- 5.6 Use of the system is limited to wet-type, special-purpose sprinkler systems and nonload-bearing wall assemblies.
- 5.7 Use of special-purpose fire sprinkler system in exterior wall applications is limited to installations where the fire separation distance is greater than 10 feet (3048 mm) under the IBC.
- 5.8 The assembly is not permitted to incorporate penetrations. Openings must be protected in accordance with applicable requirements of the IBC for opening protection.
- 5.9 The fixed glazed assembly is not permitted to be used in lieu of firewalls. Where the assemblies are used as an alternative to fire barriers for exit-passageways, horizontal exits, or exit enclosures, the fire area (Section 202 of the IBC) in which the assembly is located shall be fully sprinklered in accordance with Section 903.3.1 of the IBC. The water supply duration for sprinklers, where used, shall be not less than the fire resistance rating that would have been required for a fire barrier. In addition, the registered design professional shall provide the code official with documentation in accordance with Section 104.10 of the IBC for a code modification or Section 104.11 of the IBC for an alternative method of construction that addresses any anticipated impact on the functionality of the means of egress.

5.10 The fixed glazed assembly must not have intermediate horizontal mullions that interfere with the uniform distribution of water over the surface of the glazing.

5.11 All combustible materials must be kept a minimum distance of 2 inches (51 mm) from the face of the glass, such that the complete coverage of the glass by the sprinklers is not impeded. This is accomplished by a minimum 36-inch-high (914 mm) knee or “pony” wall at the base of the assembly. The means for maintaining clearance must be as set forth in this evaluation report.

6.0 EVIDENCE SUBMITTED

Data in accordance with the [ICC-ES Acceptance Criteria for Special-purpose Sprinklers Used with Fixed Glazed Assemblies to Provide an Alternative to a Fire-resistance-rated Wall Assembly \(AC385\)](#), dated February 2015 (editorially revised April 2021).

7.0 IDENTIFICATION

7.1 For field identification, all Victaulic Company Firelock™ Series FL-SA/WS automatic special-purpose window sprinklers (Model V2752 and Model V5648) are labeled with the manufacturer’s name (Victaulic Company), the product name, and the evaluation report number (ESR-4913).

7.2 The report holder’s contact information is the following:

VICTAULIC COMPANY
4901 KESSLERSVILLE ROAD
EASTON, PENNSYLVANIA 18040
(610) 559-3300
www.victaulic.com

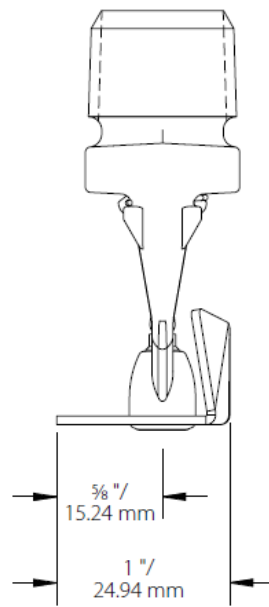
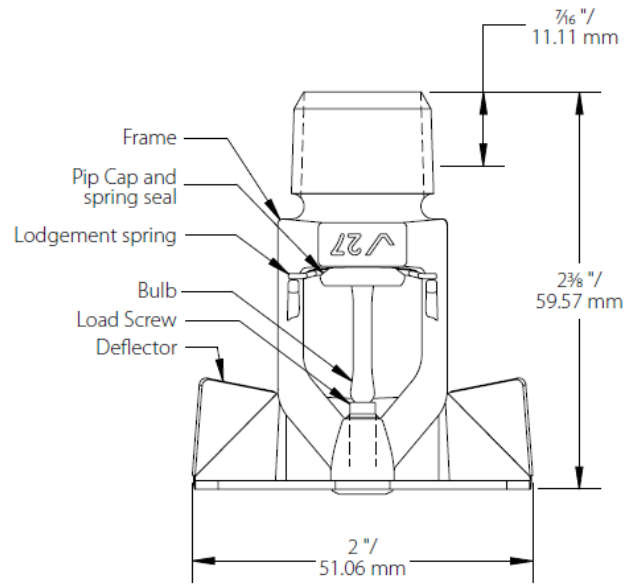

FIGURE 1—MODEL V2752 PENDENT VERTICAL SIDEWALL SPRINKLER

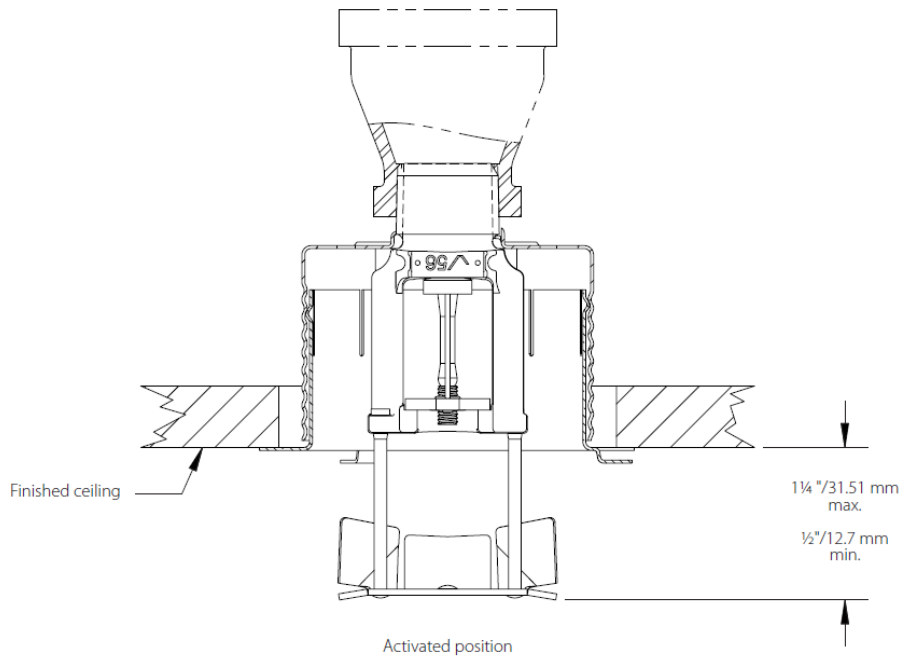
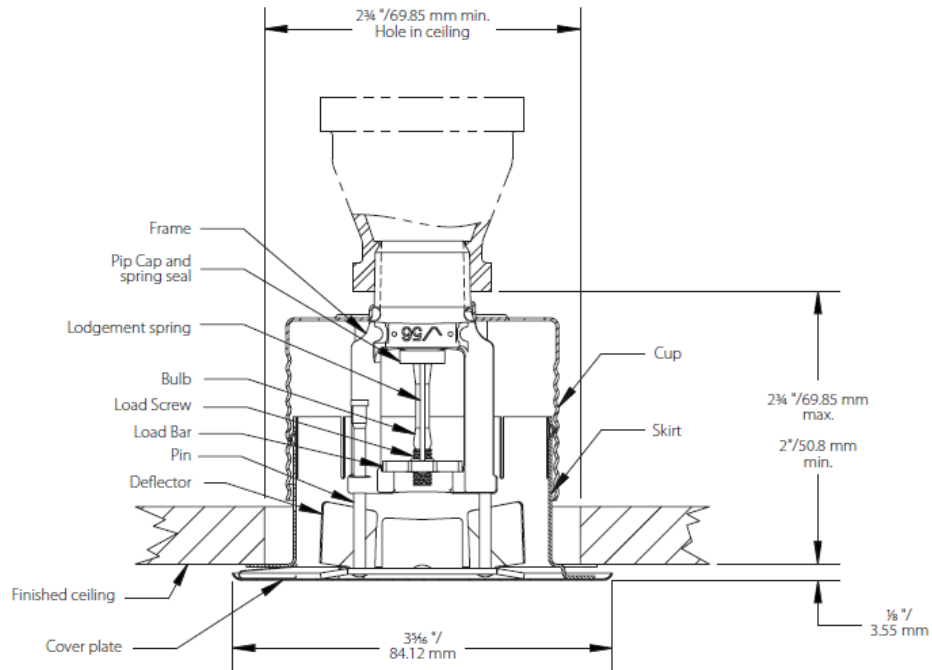
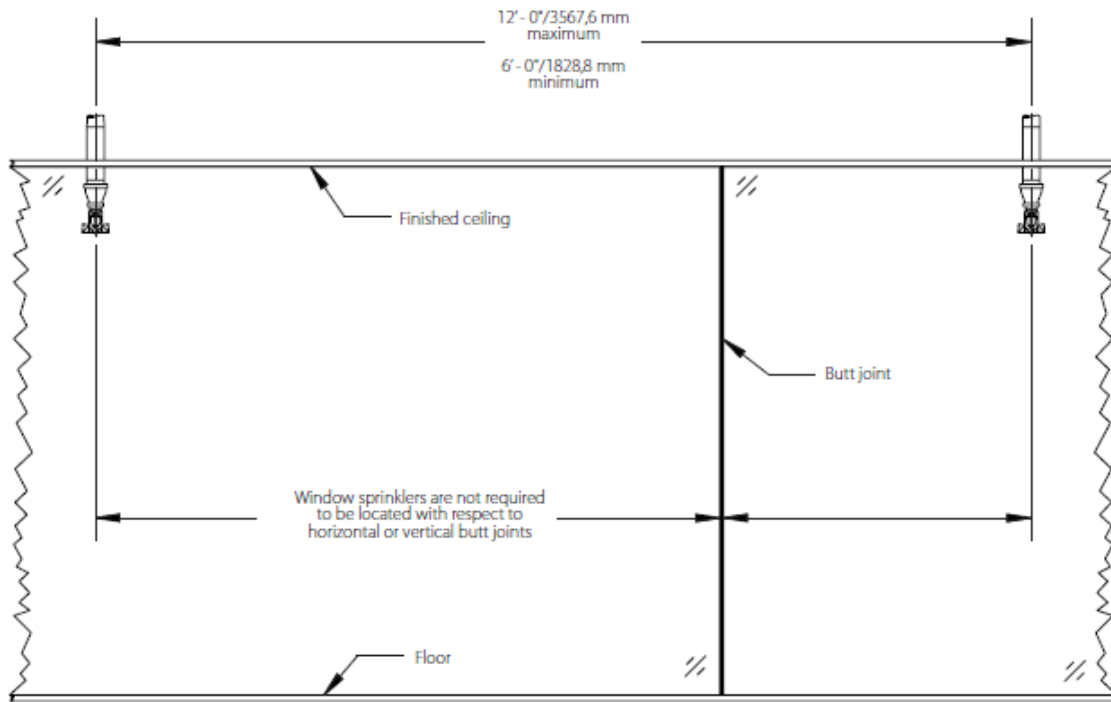

FIGURE 2—MODEL V5648 CONCEALED PENDENT VERTICAL SIDEWALL SPRINKLER



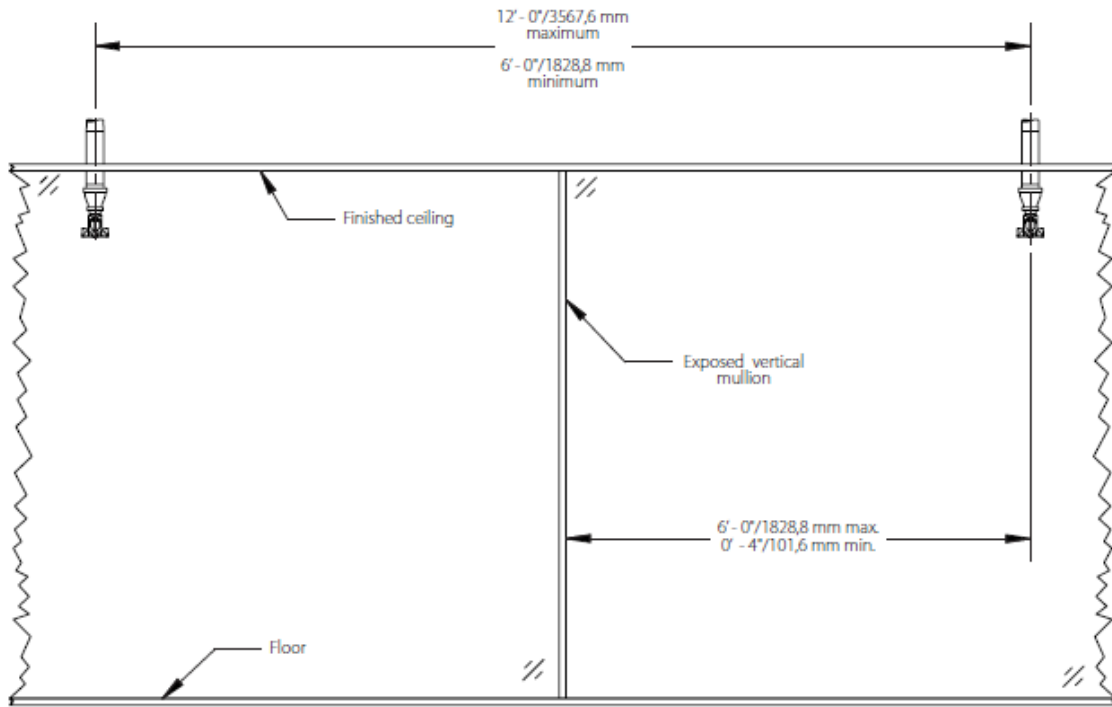

FIGURE 3—MODEL V2752 PENDENT VERTICAL SIDEWALL SPRINKLER SPACING

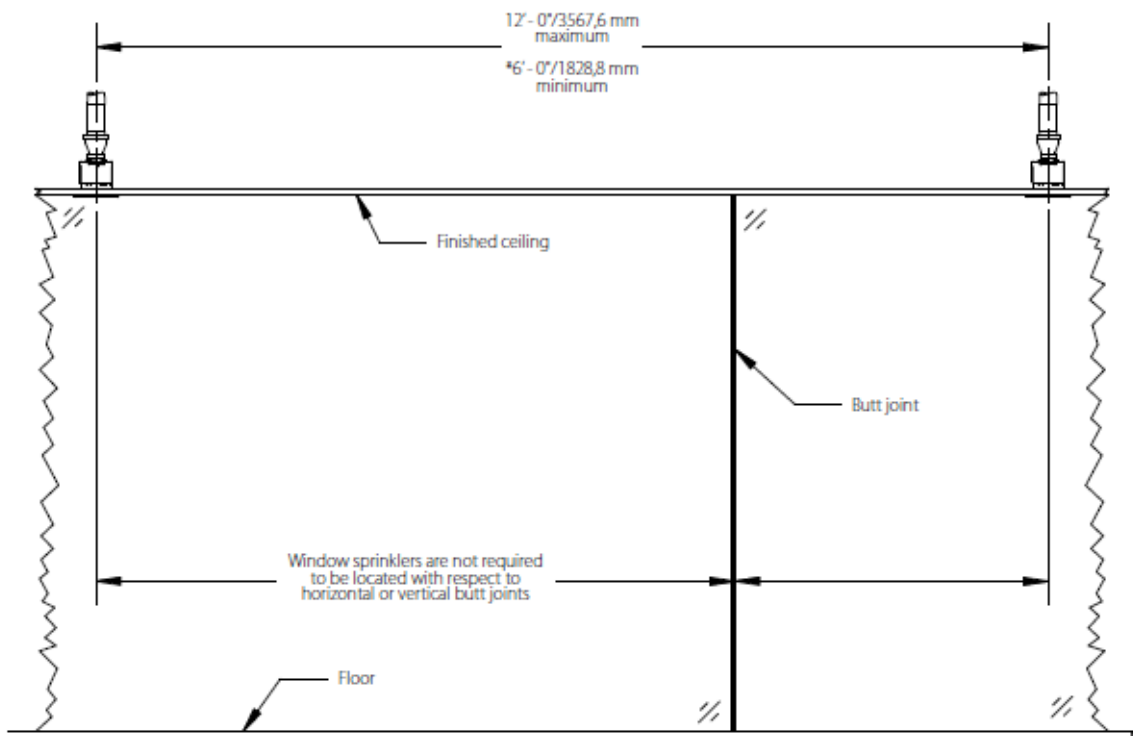
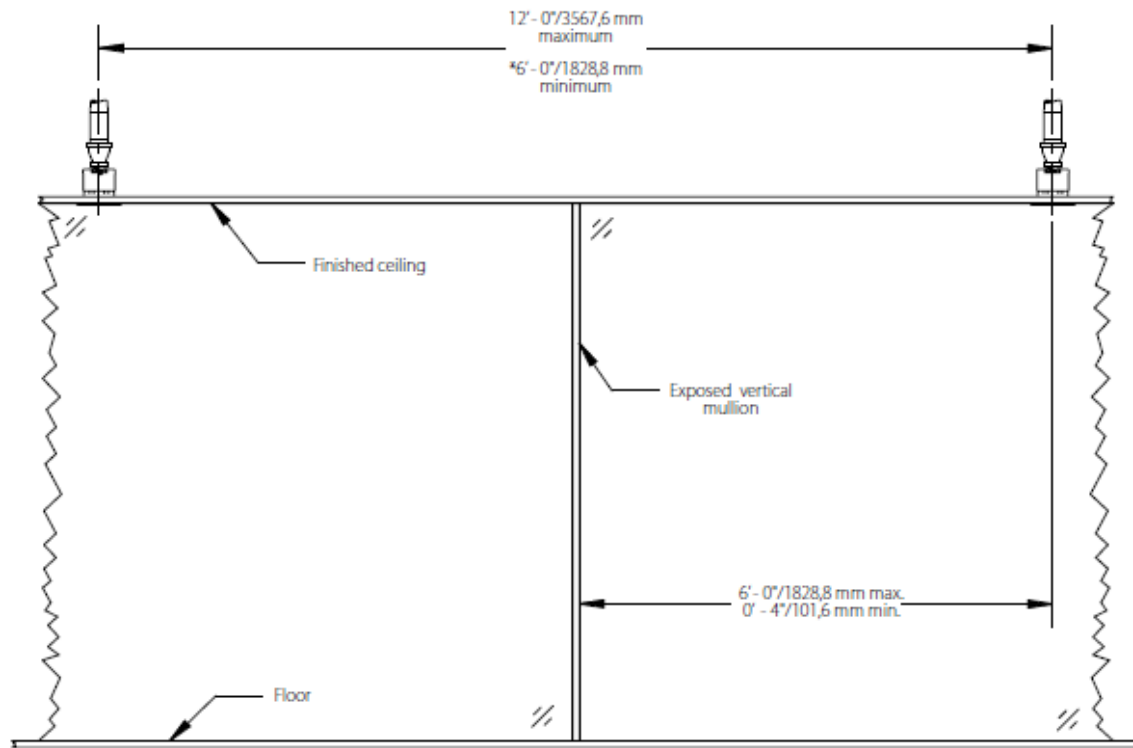

FIGURE 4— MODEL V5648 CONCEALED PENDENT VERTICAL SIDEWALL SPRINKLER SPACING

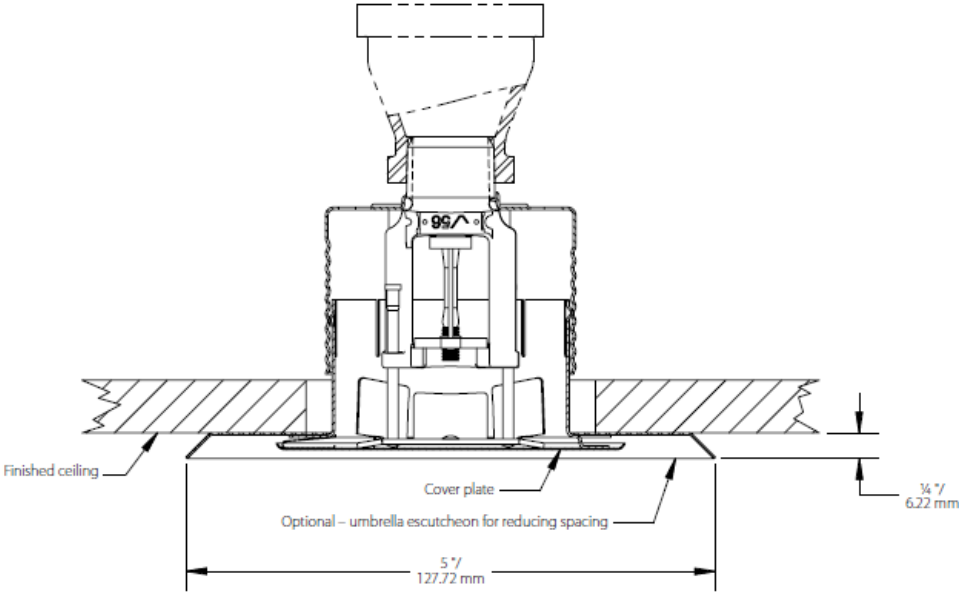
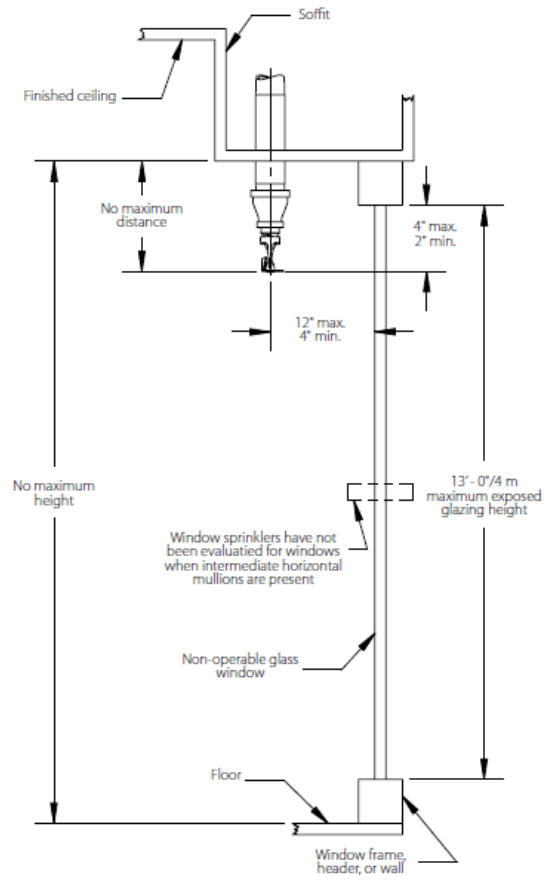

FIGURE 4A— MODEL V5648 CONCEALED PENDENT VERTICAL SIDEWALL SPRINKLER SPACING



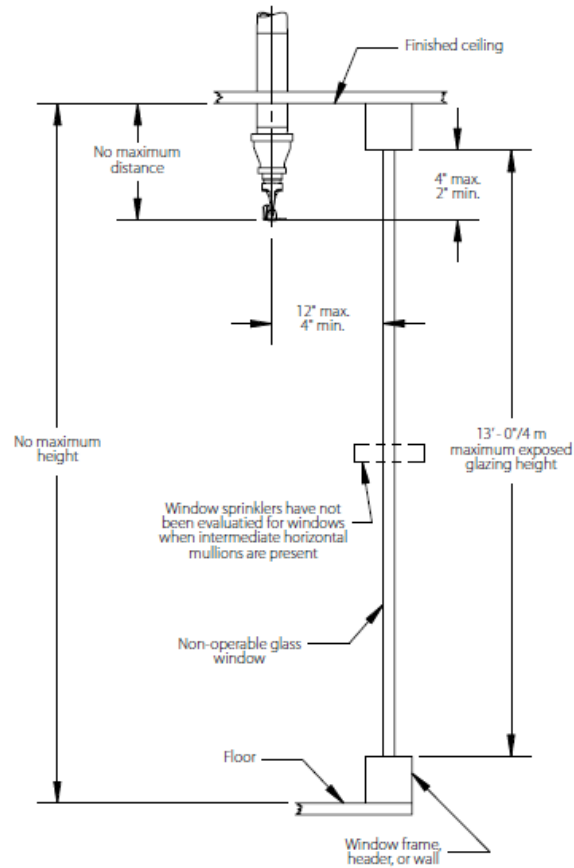

FIGURE 5—MODEL V2752 PENDENT VERTICAL SIDEWALL SPRINKLER INSTALLATION

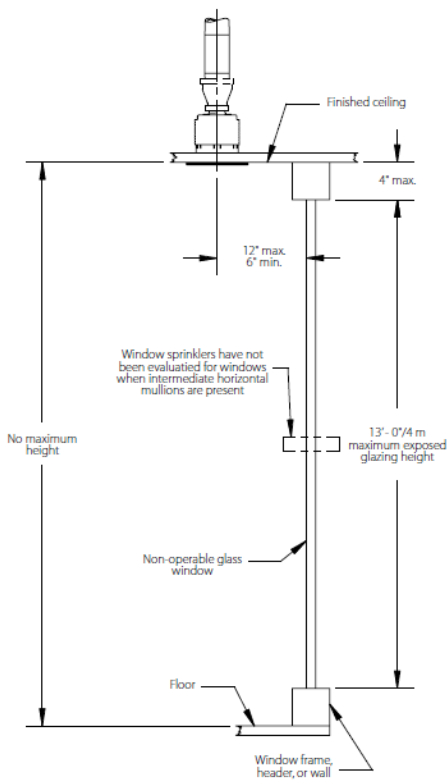
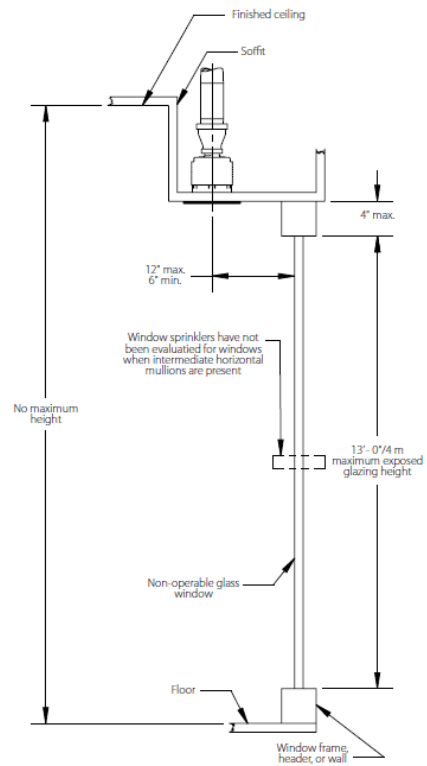

FIGURE 6—MODEL V5648 CONCEALED PENDENT VERTICAL SIDEWALL SPRINKLER INSTALLATION

DIVISION: 21 00 00—FIRE SUPPRESSION
Section: 21 13 13—Wet-Pipe Sprinkler Systems

REPORT HOLDER:

VICTAULIC COMPANY

EVALUATION SUBJECT:

**FIRELOCK™ SERIES FL-SA/WS WINDOW SPRINKLERS MODEL V2752 PENDENT SPRINKLER, MODEL V5648
CONCELAED PENDENT SPRINKLER**

1.0 REPORT PURPOSE AND SCOPE

Purpose:

The purpose of this evaluation report supplement is to indicate that the Firelock™ Series FL-SA/WS automatic special-purpose window sprinklers consisting of Model V2752 pendent sprinkler and Model V5648 concealed pendent sprinkler and the fire-resistance-rated assemblies, described in ICC-ES evaluation report ESR-4913, have also been evaluated for compliance with the code noted below.

Applicable code edition:

- 2022 and 2019 *California Building Code* (CBC)

For evaluation of applicable chapters adopted by the California Office of Statewide Health Planning and Development (OSHPD) AKA: California Department of Health Care Access and Information (HCAI) and the Division of State Architect (DSA), see Sections 2.1.1 and 2.1.2 below.

2.0 CONCLUSIONS

2.1 CBC:

The Firelock™ Series FL-SA/WS automatic special-purpose window sprinklers consisting of Model V2752 pendent sprinkler and Model V5648 concealed pendent sprinkler and the fire-resistance-rated assemblies, described in Sections 2.0 through 7.0 of the evaluation report ESR-4913, comply with CBC Chapter 7, provided the design and installation are in accordance with the 2021 and 2018 *International Building Code*® (IBC) provisions noted in the evaluation report and the additional requirements of Chapters 7 and 9, as applicable.

2.1.1 OSHPD:

The applicable OSHPD Sections of the CBC are beyond the scope of this supplement.

2.1.2 DSA:

The applicable DSA Sections of the CBC are beyond the scope of this supplement.

This supplement expires concurrently with the evaluation report, reissued September 2024.