

# ICC-ES Evaluation Report

ESR-4794

Reissued July 2024

Subject to renewal July 2025

ICC-ES Evaluation Reports are not to be construed as representing aesthetics or any other attributes not specifically addressed, nor are they to be construed as an endorsement of the subject of the report or a recommendation for its use. There is no warranty by ICC Evaluation Service, LLC, express or implied, as to any finding or other matter in this report, or as to any product covered by the report.

Copyright © 2024 ICC Evaluation Service, LLC. All rights reserved.

<p><b>DIVISION: 07 00 00— THERMAL AND MOISTURE PROTECTION</b></p> <p><b>Section: 07 42 00—Wall Panels</b></p>	<p><b>REPORT HOLDER:</b></p> <p><b>NEXII BUILDING SOLUTIONS</b></p>	<p><b>EVALUATION SUBJECT:</b></p> <p><b>NEXII ENCLOSURE CLADDING PANEL</b></p>	
---	---	--	---

## 1.0 EVALUATION SCOPE

### 1.1 Compliance with the following codes:

- 2021, 2018, 2015 and 2012 [International Building Code® \(IBC\)](#)
- 2021, 2018, 2015 and 2012 [International Residential Code \(IRC\)](#)
- 2021, 2018, 2015 and 2012 [International Energy Conservation Code® \(IECC\)](#)

### Properties evaluated:

- Structural
- Noncombustible Construction (Types I-IV)
- Fire-resistance-rated Construction
- Weather resistance
- Air Leakage

## 2.0 USES

The Nexii Enclosure Cladding Panels (NECP) are composite foam plastic panels used as exterior nonload-bearing wall panels of Type I, II, III, IV (noncombustible) or Type V building construction where fire-resistance-rated construction is required. For use as exterior wall panels where noncombustible construction is required, the panels' installation must conform to Section 4.3 of this report. For use as exterior wall in fire-resistance-rated construction, the panels installation must conform to Section 4.4 of this report. When installed in accordance with the IRC, the design and installation must comply with IRC Section R301.1.3.

When installed in accordance with this report, the NECP wall assemblies have an air leakage not greater than 0.04 cfm/ft<sup>2</sup> (0.2 L/s x m<sup>2</sup>) when tested in accordance with ASTM E283 and comply with the 2021 IECC Section C402.5.1.4 (2018 and 2015 IECC Section C402.5.1.2.2 or 2012 IECC Section C404.4.1.2.2), as applicable.

## 3.0 DESCRIPTION

### 3.1 General:

The NECP are factory-assembled, proprietary polymer concrete-faced, insulated panels with an expanded polystyrene (EPS) foam core supported by a steel framework. NECP are intended for use as a complete exterior wall envelope solution and come in 10 and 12-inch thickness (254 and 305 mm). The panels are custom made to meet the specifications of each use and are assembled under factory controlled conditions. The maximum size is up to 13 feet (3.96 m) in width and up to 40 feet (12.19 m) in length. The panel can be oriented vertically or horizontally based on the panel support conditions.

### 3.2 Materials:

**3.2.1 Panel Core:** The core of the wall panels is EPS foam plastic conforming to ASTM C578, Type II. The foam core has a flame-spread index of 25 or less and a smoke-developed index of 450 or less when tested in accordance with ASTM E84. The foam plastic core comes in thicknesses of 9 and 11 inches (229 and 279 mm).

**3.2.2 Facing:** Facing consists of minimum ½-inch-thick (12.7 mm) layers of proprietary cementitious coatings, designated as Nexiite ST as specified in the approved quality control documentation. Prior to application of the coating, the frame and foam core assembly are covered with an alkaline resistant glass mesh. In addition to the glass mesh, the exterior coating surface of the panel assembly is also covered with a layer of chopped strand glass mat. The Nexiite ST facing is applied on the mesh surfaces, fully encapsulating the EPS core and the steel framework components except at connection points. When used in Types I-IV construction, a minimum ¾-inch-thick (19 mm) layer of Nexiite FS coating is applied over the Nexiite ST layer on the interior side of the panels only to increase fire performance. NECP that include the FS coating are designated as NECP-FR. Otherwise, the NECP are designated as standard panels.

**3.2.3 Structural Steel Framework:** An internal steel framework is encased with the panel to provide structural stability and connection to the supporting structure. The structural steel framework also incorporates corner blocks used to lift the panels. The maximum spacing of the internal steel elements must be determined by a registered design professional. The steel framework and connection of the panel to the supporting structure are outside the scope of this report and must be designed by a registered design professional.

**3.2.4 Joints:** Panel joints must be filled with mineral wool insulation and backer rod. A bead of an approved silicone-sealant complying with ASTM C920 must be applied at each panel joint, unless noted otherwise. See [Figures 2](#) through [8](#) for typical joint details.

**3.2.5 Flashing:** Flashing material must be corrosion-resistant metal and installed in accordance with the code.

## 4.0 DESIGN AND INSTALLATION

### 4.1 Design:

An analysis must be submitted to the code official showing that the panel system, including fasteners and structural steel framework, provides a complete load path capable of transferring all loads and forces from their point of origin to load-resisting elements. The NECP allowable positive and negative transverse load capacity, excluding steel framework, is 49 psf (2.35 kPa) for panels spanning 12.5 ft (3.81 m) on center and 68 psf (3.26 kPa) for panels spanning 9.5 ft (2.90 m) on center and having a minimum EPS foam core thickness of 9 inches (229 mm) and minimum ½-inch-thick (12.7 mm) Nexii ST coating on EPS foam faces. The steel framework and connection of the steel framework to the NECP must be designed by a registered design professional.

### 4.2 Installation:

**4.2.1 General:** NECP must be fabricated and installed in accordance with this report, the approved construction documents, and the applicable code. In the event of a conflict between the manufacturer's published installation instructions, approved construction documents and this report, the most stringent requirement must govern.

**4.2.2 Connections:** NECP are connected at the panel edges through corner connections. The panel-to-panel joints must be sealed in accordance with [Figure 4](#), unless otherwise noted in this report.

**4.2.3 Cutting and Notching:** No field cutting or routing of the panels shall be permitted except as shown in the approved construction documents.

**4.2.4 Protection from Termite Resistance and Decay:** NECP that rest on exterior foundation walls shall not be located within 6 inches (152 mm) above ground to establish compliance with IBC Section 2603.8 (2012 IBC Section 2603.9). Corrosion protection of structural steel framework must be provided as determined by registered design professional.

**4.2.5 Heat-producing Fixtures:** Heat producing fixtures shall not be installed in the NECP unless protected by a method approved by the code official. This limitation shall not be interpreted to prohibit heat producing elements with suitable protection.

**4.2.6 Plumbing Installation Restrictions: Plumbing and** waste lines may extend at right angles through the wall panels but are not permitted vertically within the core. Lines shall not interrupt steel framework or panel connections unless approved by registered design professional.

#### **4.2.7 Voids and Holes:**

**4.2.7.1 Voids in Core:** In lieu of panel openings designed by registered design professional. The following voids may be provided in the panel core during fabrication at predetermined and approved locations.

**4.2.7.2 Holes in Panels:** Holes may be placed in NECP panels at predetermined locations only. Except as noted herein, holes shall be limited to 8 inch by 8 inch square (203 by 203 mm). For multiple holes, the maximum hole size is 4 inch by 4 inch square (102 mm by 102 mm). There must be a minimum spacing between holes of 8 inches (203 mm), otherwise holes must be designed as larger openings by registered design professional. All hole openings must be at least 8 inches (203 mm) from panel edges.

#### **4.2.8 Panel Cladding:**

**4.2.8.1 Exterior Wall Covering:** NECP provide exterior wall finish on the outer skin layer. The NECP joints and penetrations must be sealed in accordance with [Figures 2](#) through [8](#).

**4.2.8.2 Interior Wall Covering:** The interior face of NECP have been classified as Class A in accordance with IBC Section 803.1.1. The NECP is not required to be separated from the interior of the building by a thermal barrier based on testing in accordance with IBC Section 2603.9 (2012 IBC Section 2603.10).

**4.3 Types I, II, III, and IV (Noncombustible) Construction:** The NECP-FR must be installed in accordance with Section 4.2 of this report. In addition, the following installation requirements must be followed:

- The EPS foam core thickness must not exceed 10.75 inches (273 mm).
- The minimum ST facing coating thickness must be ½-inch-thick (12.7 mm). The minimum FS facing coating thickness must be ¾-inch-thick (19 mm).
- The panel-to-panel joints must not exceed 1¼-inch-width (32 mm). The joints must be filled with 6 pcf (96 kg/m<sup>3</sup>) mineral fiber insulation complying with ASTM C665 and backer rod. Tremco Dynamic 100 polyurethane caulking must be applied on panel joints on the backer rod on the interior face of the panels. Tremco Spectrem 1 silicone caulking must be applied on panel joints on top of the backer rod on the exterior face of the panels.
- Three inches (76 mm) of EPS foam must be removed around the opening (window) perimeter on the exterior side of the panel and filled with 6 pcf (96 kg/m<sup>3</sup>) mineral wool insulation to a depth of 3 inches (76 mm) and covered with a 1/16-inch-thick (1.59 mm) layer of 3M CP25WB+fire caulking. The opening perimeter steel frame work must be covered with alkaline resistant mesh and ½-inch-thick (12.7 mm) ST coating.
- The NECP must comply with the dimensions reported in Section 4.1 of this report.
- Fireblocking must be in accordance with IBC Section 718.2.

**4.4 Fire-resistance-rated Construction Wall Assembly:** The NECP-FR must be installed in accordance with Section 4.2 of this report and the following requirements to achieve a one-hour nonload-bearing exterior wall assembly rated from the interior side:

- The EPS foam core thickness must not exceed 10.75 inches (273 mm).
- The minimum ST facing coating thickness must be ½-inch-thick (12.7 mm) on the exterior side. The interior side must be coated with ½-inch-thick (12.7 mm) ST coating over the EPS foam core followed by ¾-inch-thick (19 mm) FS facing coating and covered with ¼-inch-thick (6 mm) ST facing coating.
- The panel-to-panel joints must not exceed 1¼-inch-width (32 mm). The joints must be filled with mineral fiber insulation having a nominal density of 4 pcf (64 kg/m<sup>3</sup>) and packed to a depth of 5.75 inches. The mineral fiber insulation must comply with ASTM C665 and backer rod. The mineral fiber insulation must be recessed 1.25 inches (32 mm) from the interior face and 3.25 inches (83 mm) from the exterior face. A foam backer rod must be placed in the interior and exterior joint in front of the mineral fiber insulation. A 0.5-inch (12.7 mm) bead of Rapid Set Non-Sag Hybrid Silane Polyether sealant must be placed over the foam backer rod at the interior and exterior joints. At the exterior joint, an additional foam backer rod must be placed over the sealant and the joint must be filled with 0.5-inch (12.7 mm) bead of the same sealant.
- The NECP must comply with the dimensions reported in Section 4.1 of this report.

## 5.0 CONDITIONS OF USE:

The Nexii NECP described in this report comply with, or are suitable alternatives to what is specified in, those codes listed in Section 1.0 of this report, subject to the following conditions:

- 5.1 Panels must be installed in accordance with this report and the manufacturer's published installation instructions, a copy of which must be available at the jobsite. In the event of a conflict between this report and the manufacturer's published installation instructions, the more restrictive governs.
- 5.2 Wall panels must be limited to nonload-bearing wall applications, .
- 5.3 Remaining portions of the structure, other than panels, must be designed and constructed in accordance with the code.
- 5.4 Construction plans, calculations for actual loading conditions and calculations for the connection of the panel to the supporting member must be submitted to the code official for approval.
- 5.5 All construction documents specifying the panels described in this report must comply with the design limitations of this report. Drawings and design details demonstrating that the panels comply with this report must be submitted to the code official at the time of permit application. The drawings and design details must be prepared by a registered design professional where required by the statutes of the jurisdiction in which the project is to be constructed.
- 5.6 The panels described in this report have been justified for installation without the thermal barrier required by IBC Section 2603.4.
- 5.7 The panels are fabricated by Nexii Building Solutions under a quality-control program with inspections by ICC-ES.

## 6.0 EVIDENCE SUBMITTED

- 6.1 Physical properties tests of facing material in accordance with ASTM C947, ASTM C297, ASTM E2098, ASTM C109, ASTM C948, ASTM C188 and ASTM C531 and ASTM G155.
- 6.2 Data in accordance with the [ICC-ES Acceptance Criteria for Sandwich Panels \(AC04\)](#), dated June 2019 (editorially revised December 2020)
- 6.3 Structural transverse load tests per ASTM E72.
- 6.4 Water penetration tests per ASTM E331.
- 6.5 Assembly air leakage testing per ASTM E283.
- 6.6 Data in accordance with the [ICC-ES Acceptance Criteria for Foam Plastic Insulation \(AC12\)](#), dated June 2015 (editorially revised December 2020).
- 6.7 Reports of fire testing in accordance with ASTM E119, NFPA 285, NFPA 259, NFPA 268 and NFPA 286.

## 7.0 IDENTIFICATION

- 7.1 The ICC-ES mark of conformity, electronic labeling, or the evaluation report number (ICC-ES ESR-4794) along with the name, registered trademark, or registered logo of the report holder [Nexii Building Solutions] must be included in the product label.
- 7.2 In addition, each panel is identified with a product label and the product designation.
- 7.3 The report holder's contact information is the following:

**NEXII BUILDING SOLUTIONS**  
**1455 WEST GEORGIA STREET**  
**VANCOUVER, BRITISH COLUMBIA V6G 2T3**  
**CANADA**  
**(778) 926-3944**  
[www.nexii.com](http://www.nexii.com)

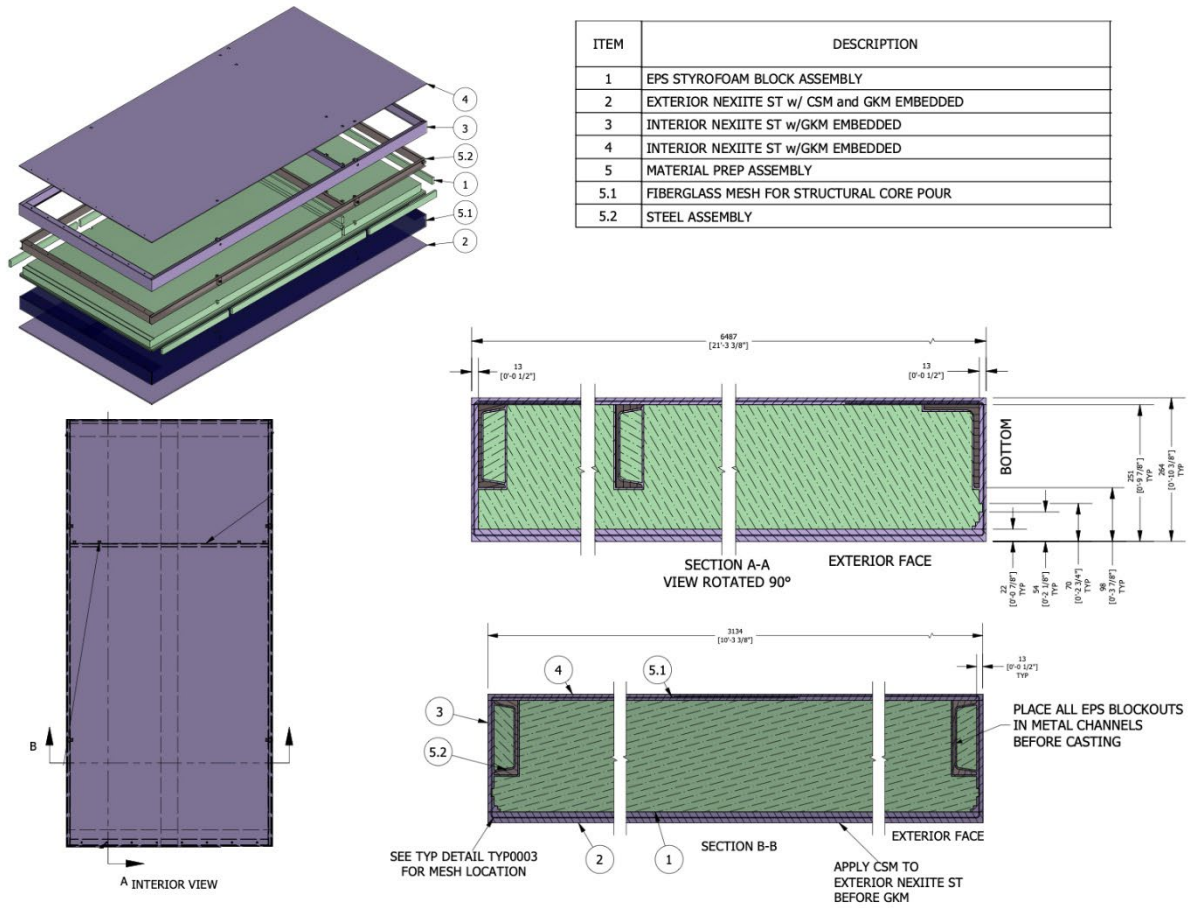

FIGURE 1—TYPICAL NEXII HPE PANEL

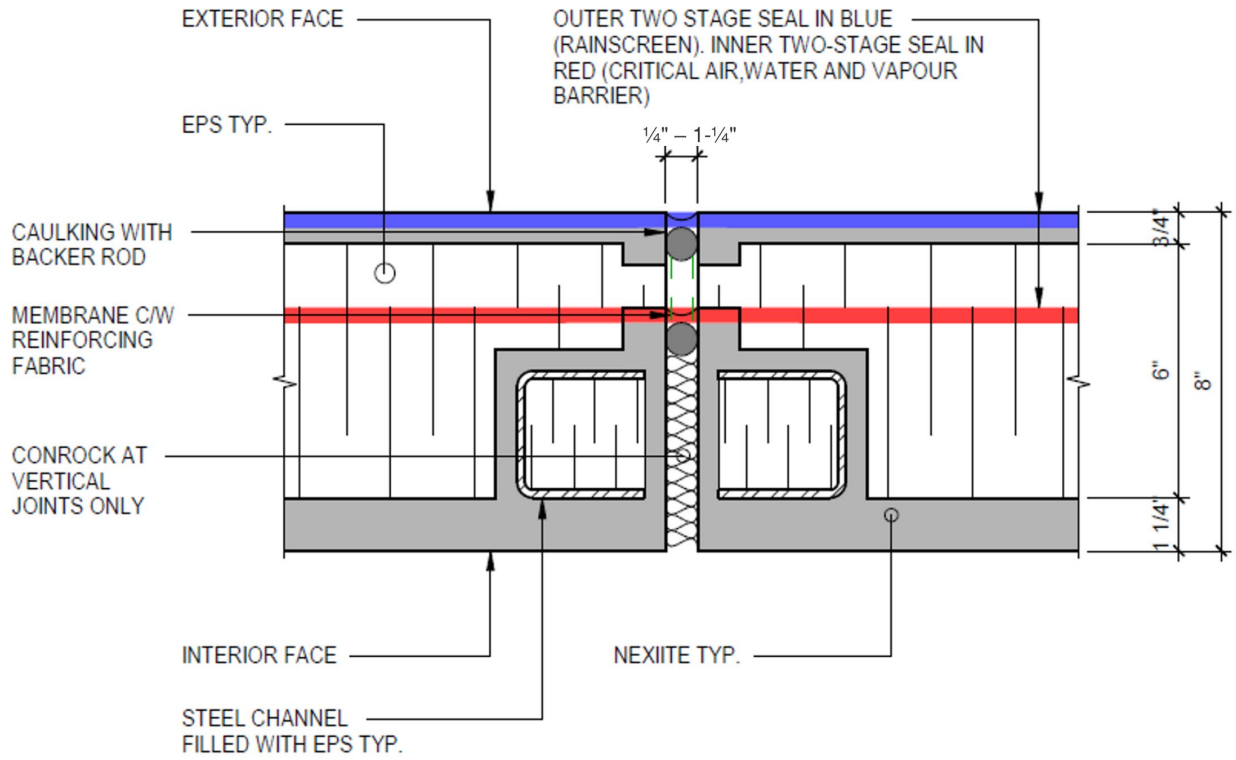

FIGURE 2—TYPICAL VERTICAL PANEL JOINT DETAIL

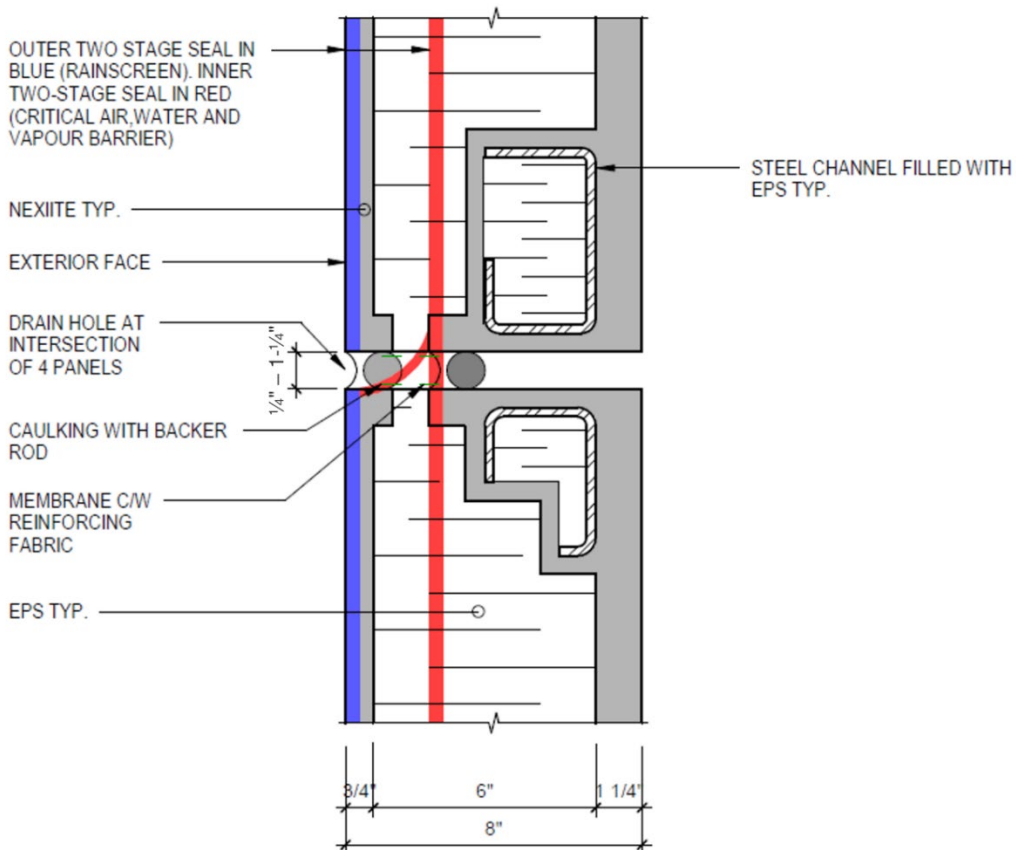

FIGURE 3—TYPICAL HORIZONTAL JOINT DETAIL



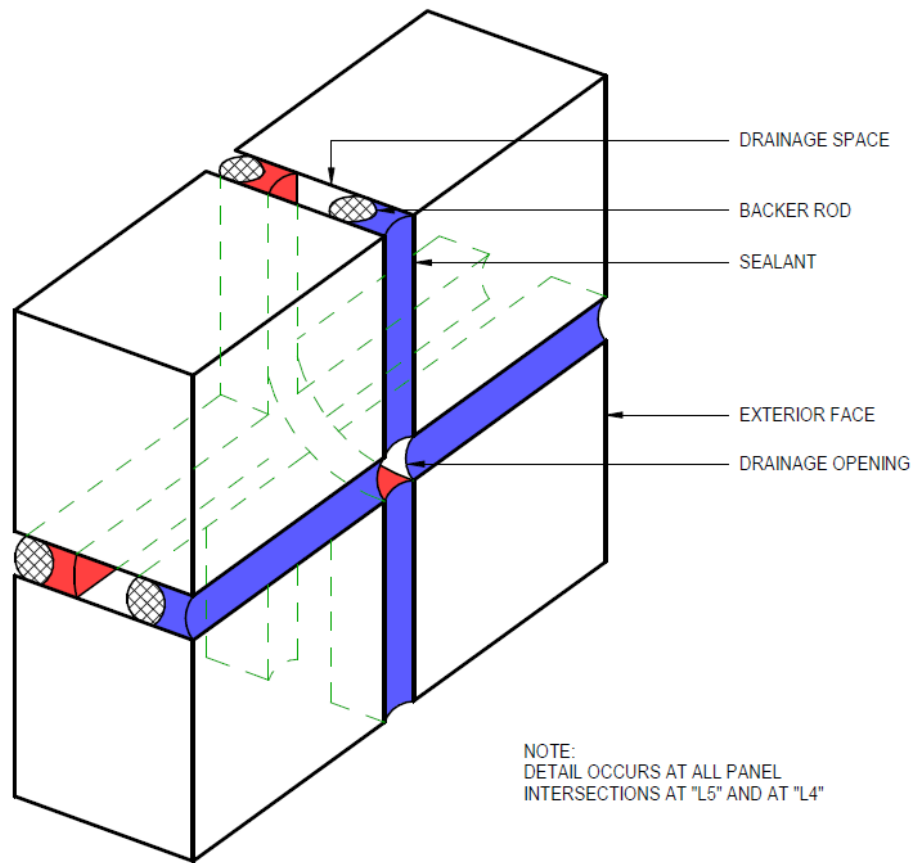

FIGURE 4—TYPICAL PANEL INTERSECTION JOINT DETAILS SHOWING TWO STAGE SEAL AND WEEPHOLES

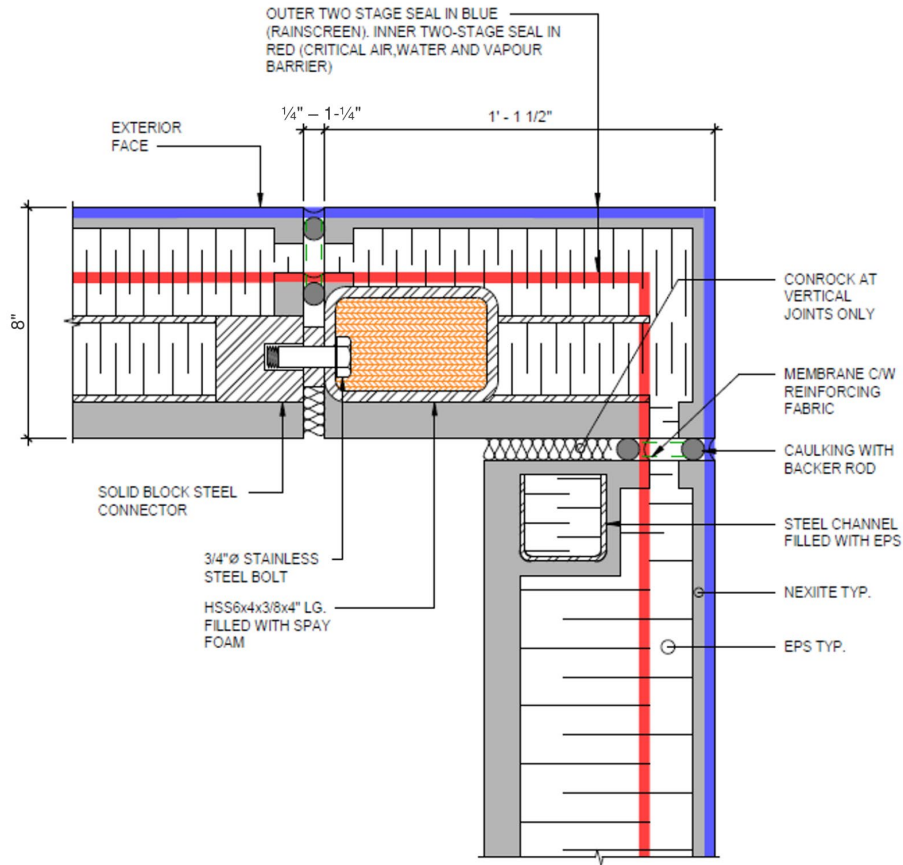

FIGURE 5—CORNER PANEL DETAIL JOINT SEAL

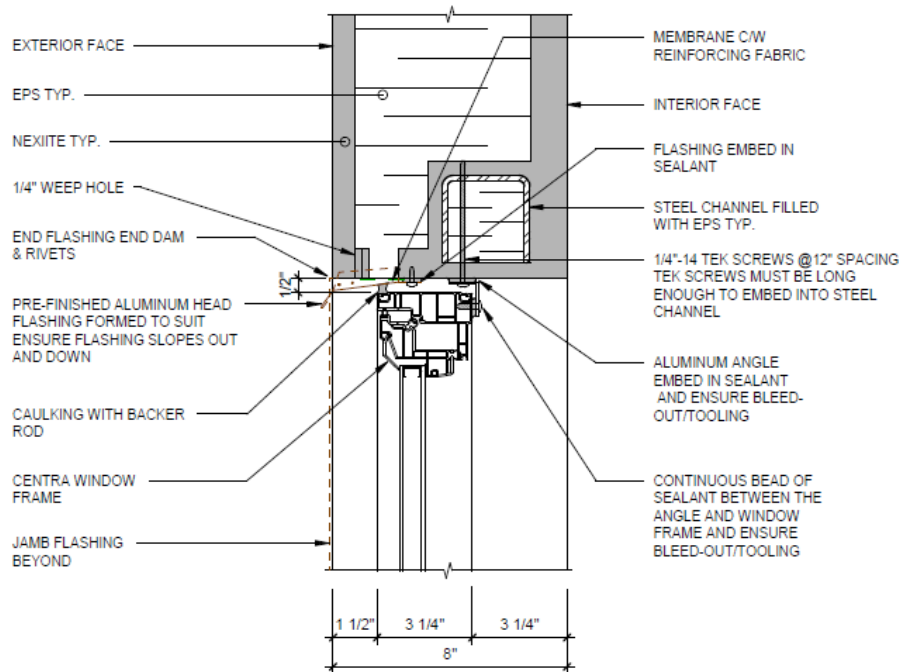

FIGURE 6—TYPICAL WINDOW HEAD DETAIL



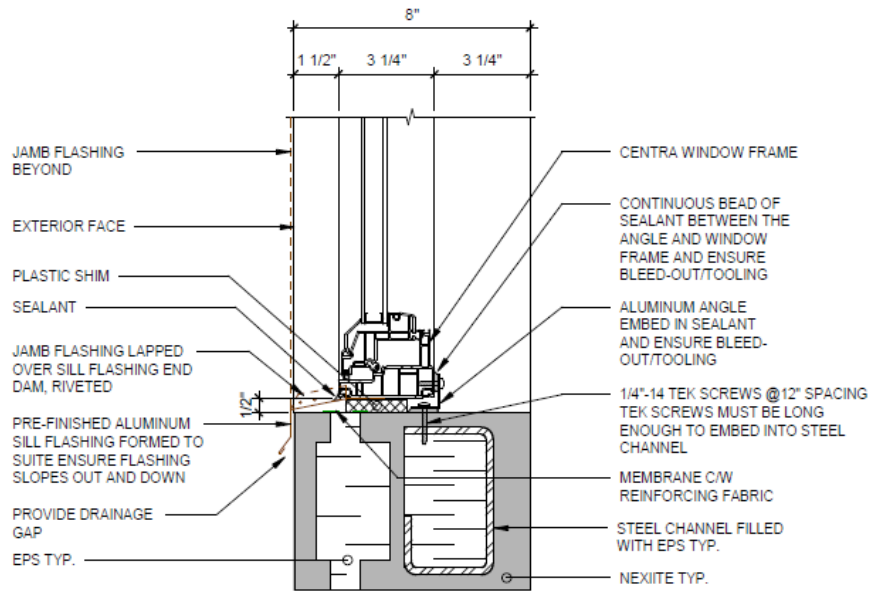

FIGURE 7—TYPICAL WINDOW SILL DETAIL

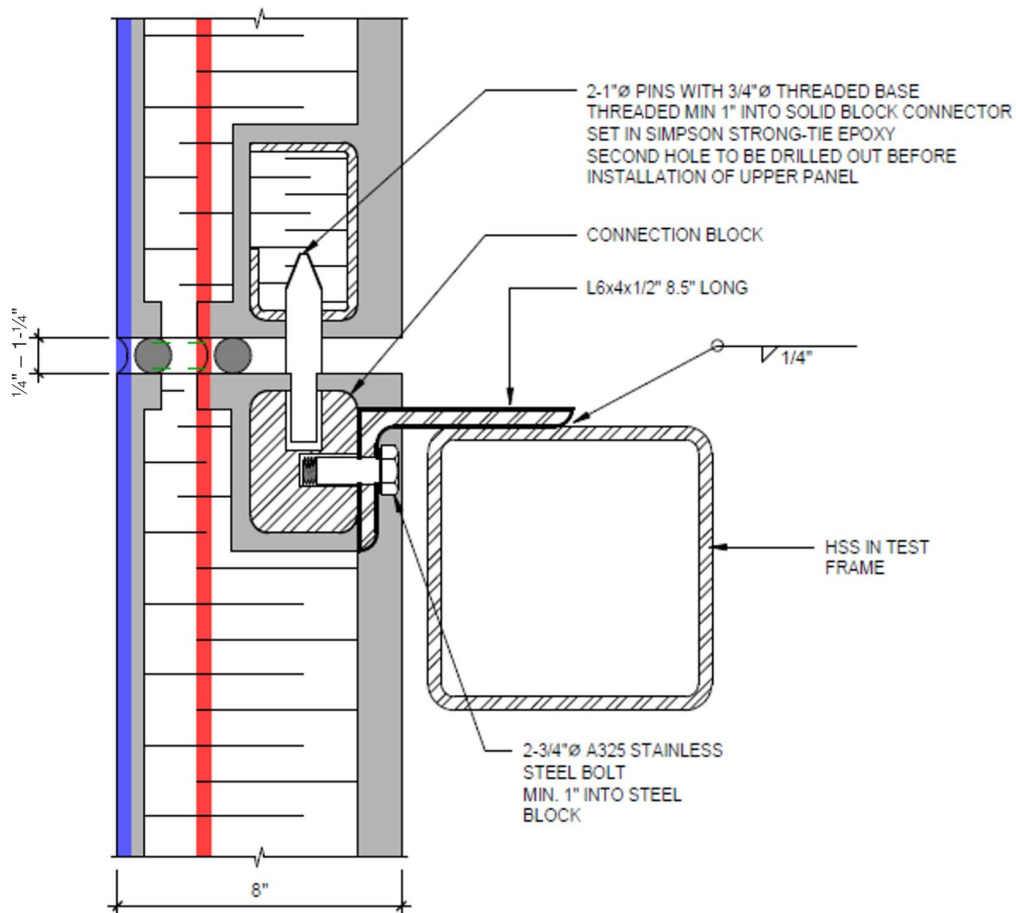

FIGURE 8—TYPICAL PANEL TO FLOOR SLAB CONNECTION JOINT DETAIL