

ICC-ES Evaluation Report

ESR-4784

Reissued February 2024

Revised September 2024

Subject to renewal February 2025

ICC-ES Evaluation Reports are not to be construed as representing aesthetics or any other attributes not specifically addressed, nor are they to be construed as an endorsement of the subject of the report or a recommendation for its use. There is no warranty by ICC Evaluation Service, LLC, express or implied, as to any finding or other matter in this report, or as to any product covered by the report.

Copyright © 2024 ICC Evaluation Service, LLC. All rights reserved.

<p>DIVISION: 06 00 00— WOOD, PLASTICS, AND COMPOSITES</p> <p>Section: 06 12 00— Structural Panels</p>	<p>REPORT HOLDER: THE MURUS COMPANY</p>	<p>EVALUATION SUBJECT: MURUS PUR SIPs</p>	
--	---	---	---

1.0 EVALUATION SCOPE

Compliance with the following codes:

- 2024, 2021, 2018, and 2015 [International Building Code® \(IBC\)](#)
- 2024, 2021, 2018, and 2015 [International Residential Code® \(IRC\)](#)

Property Evaluated:

- Structural

2.0 USES

2.1 General:

Murus PUR SIPs are used as structural insulated roof and wall panels capable of resisting transverse, axial and in-plane shear loads.

2.2 Construction Types:

Murus PUR SIPs shall be considered combustible building elements when determining the construction type in accordance with IBC Chapter 6.

2.3 Fire Resistive Assemblies:

Murus PUR SIPs shall not be used as part of a fire-rated assembly unless suitable evidence and details are submitted and approved by the authority having jurisdiction.

3.0 DESCRIPTION

3.1 General:

Murus PUR SIPs are factory-assembled, engineered-wood faced, structural insulated panels (SIPs) with foamed-in-place polyurethane (PUR) foam plastic core. The product is intended for use as load-bearing or non-load bearing wall and roof components. Murus PUR SIPs are available in 4⁵/₈-inch (117.5 mm), 5⁵/₈-inch (143 mm), and 6⁵/₈-inch (168 mm) overall thicknesses and are custom made to the specifications for each use. The maximum product size is 4 feet (1219 mm) wide and 24 feet (7315 mm) long.

3.2 Material:

3.2.1 Facing:

The facing consists of two single-ply oriented strand board (OSB) facings a minimum of 7/16-inch-thick (11.1 mm) conforming to the properties shown in [Table 3](#). Additionally, facing materials shall conform to DOC PS 2, Exposure 1, Rated Sheathing with a span index of 24/16. Panels are manufactured with the facing strength axis oriented parallel to the direction of panel bending.

3.2.2 Core:

The foamed-in-place polyurethane foam core has a minimum 2.2 pcf (35.2 kg/m³) in-place density and self-adheres to the facing. The foam core, up to 4-inch (102 mm) thickness, has a flame spread index not exceeding 25 and a smoke-developed index not exceeding 450 when tested in accordance with ASTM E84. Cores used in structural insulated panels up to 6⁵/₈-inch (168 mm) thick, comply with IBC Section 2603.3 Exception 4.

3.2.3 Material Sources:

The facing and core materials used in the construction of Murus PUR SIPs are from approved sources as identified in the in-plant quality system documentation.

3.2.4 Splines:

Murus PUR SIPs are interconnected with surface splines or a cam-lock system ([Figure 1](#)). Connections using dimensional lumber splines or engineered structural splines are not specifically addressed in this report and must be designed in accordance with accepted engineering practice to meet applicable code requirements.

4.0 DESIGN AND INSTALLATION

4.1 Design:

4.1.1 Overall Structural System:

The scope of this report is limited to the evaluation of the SIP component. Panel connections and other details related to incorporation of the product into the overall structural system of a building are beyond the scope of this report.

4.1.2 Design Approval:

Where required by the authority having jurisdiction, structures using Murus PUR SIPs shall be designed by a registered design professional. Construction documents, including engineering calculations and drawings providing floor plans, window details, door details and connector details, shall be submitted to the code official when application is made for a permit. The individual preparing such documents shall possess the necessary qualifications as required by the applicable code and the professional registration laws of the state where the construction is undertaken. Approved construction documents shall be available at all times on the jobsite during installation.

4.1.3 Design Loads:

Design loads to be resisted by the product shall be as required under the applicable code. Loads on the panels shall not exceed the loads noted in this report. Where loading conditions result in superimposed stresses, the sum of the ratio of actual loads over allowable loads shall not exceed one. Calculations demonstrating that the loads applied are less than the allowable loads described in this report shall be submitted to the code official for approval.

4.1.4 Allowable Loads:

Allowable axial, transverse, and in-plane shear loads may be calculated using the panel properties provided in [Tables 1](#) and [2](#) or selected from [Tables 4](#), [5](#), [6](#), [7](#) or [8](#). For loading conditions not specifically addressed herein, structural members designed in accordance with accepted engineering practice shall be provided to meet applicable code requirements. Allowable loads are provided for product in the dry end use condition.

4.1.5 Concentrated Loads:

Axial loads shall be applied to the product through continuous members such as structural insulated roof or floor panels or repetitive members such as joists, trusses or rafters spaced at regular intervals of 24-in. on center or less. Such members shall be fastened to a rim board or similar member to distribute the load to the product. For other loading conditions, reinforcement shall be provided. This reinforcement shall be designed in accordance with accepted engineering practice.

4.1.6 Eccentric and Side Loads:

Axial loads shall be applied concentrically to the top of the product. Loads shall not be applied eccentrically or through framing attached to one side of the panel (such as balloon framing) except where additional engineering documentation is provided.

4.1.7 Openings:

Openings in panels shall be reinforced with wood or steel designed in accordance with accepted engineering practice to resist all loads applied to the opening as required by the adopted code. Details for door and window openings shall be provided to clarify the manner of supporting axial, transverse and/or in-plane shear loads at openings. Such details shall be subject to approval by the local authority having jurisdiction.

4.1.8 In-Plane Shear Design:

Shear walls shall be sized to resist all code required wind and seismic loads without exceeding the allowable loads provided herein. Shear wall chords, hold-downs and connections to transfer shear forces between the wall and surrounding structure shall be designed in accordance with accepted engineering practice. Allowable strengths for SIP shear walls with structural splines along each panel edge shall be designed in accordance with accepted engineering practice and are subject to the limitations for wood sheathed shear walls.

4.1.8.1 Seismic Design Categories A, B and C:

Use of the shear wall configurations in [Table 5](#) is limited to structures in Seismic Design Categories A, B and C. Where SIPs are used to resist seismic forces the following factors shall be used for design: Response Modification Coefficient, $R = 2.0$; System Overstrength Factor, $\Omega_o = 2.5$; Deflection Amplification Factor, $C_d = 2.0$. The maximum panel height-to-width ratio shall be 2:1.

4.1.2 Combined Loads:

Panels subjected to any combination of transverse, axial or in-plane shear loads shall be analyzed utilizing a straight line interaction. [Tables 6](#) through [8](#) provide examples of combined axial and transverse load capacities for common transverse load conditions.

4.2 Installation:

4.2.1 General:

Murus PUR SIPs shall be fabricated, identified and erected in accordance with this report, the approved construction documents and the applicable codes. In the event of a conflict between the manufacturer's published installation instructions and this report, this report shall govern. Approved construction documents shall be available at all times on the jobsite during installation.

4.2.2 Splines:

Murus PUR SIPs are interconnected at the panel edges through the use of a surface spline or cam-lock system, as shown in [Figure 1](#). When cam-locks are used to connect panels, the cam-locks are spaced no less than 24 inches (610 mm) on center. All joints shall be sealed in accordance with the SIP manufacturer's installation instructions.

4.2.3 Plates:

The top and bottom plates of the panels shall be dimensional or engineered lumber sized to match the core thickness of the panel. The plates shall be secured using not less than 0.131-inch x 2-1/2-inch (2.9 mm x 63.5 mm) nails, spaced 6 inches (152 mm) on center on both sides of the panel or an approved equivalent fastener. See [Table 5](#) and [Figure 3](#) for more details on plate fasteners.

4.2.4 Cutting and Notching:

No field cutting or routing of the panels shall be permitted except as shown on approved construction documents from a registered design professional.

4.2.5 Protection from Decay:

SIPs that rest on exterior foundation walls shall not be located within 8 inches (204 mm) of exposed earth. SIPs supported by concrete or masonry that is in direct contact with earth shall be protected from the concrete or masonry by a moisture barrier.

4.2.6 Protection from Termites:

In areas subject to damage from termites, SIPs shall be protected from termites using an approved method. Panels shall not be installed below grade or in contact with earth.

4.2.7 Heat-Producing Fixtures:

Heat-producing fixtures shall not be installed in the panels unless protected by a method approved by the code official or documented in test reports. This limitation shall not be interpreted to prohibit heat-producing elements with suitable protection.

4.2.8 Voids and Holes

4.2.8.1 Voids in Core:

In lieu of openings designed in accordance with section 4.1.7, the following voids are permitted. Voids may be provided in the panel core during fabrication at predetermined locations only. Voids parallel to the panel span shall be limited to a single 1-inch (25.4 mm) maximum diameter hole. Such voids shall be spaced a minimum of 4 feet (1219 mm) on center measured perpendicular to the panel span. Two 1/2-inch (12.7 mm) diameter

holes may be substituted for the single 1-inch (25.4 mm) hole provided they are maintained parallel and within 2 inches (51 mm) of each other. Voids perpendicular to the panel span shall be limited to a single 1-inch (25.4 mm) maximum diameter hole placed not closer than 18 inches (457 mm) from the support. Additional voids in the same direction shall be spaced not less than 24 inches (610 mm) on center.

4.2.8.2 Holes in Panels:

Holes may be placed in panels during fabrication at predetermined locations only. Holes shall be limited to 4-inch-by-4-inch (102 mm by 102 mm) square. The minimum distance between holes shall not be less than 4 feet (1219 mm) on center measured perpendicular to the panel span and 24 inches (610 mm) on center measured parallel to the panel span. Not more than three holes shall be permitted in a single line parallel to the panel span. The holes may intersect voids permitted elsewhere in this report.

4.2.9 Panel Cladding

4.2.9.1 Roof Covering:

The roof covering, underlayment and flashing shall comply with the applicable codes. All roofing materials must be installed in accordance with the manufacturer's installation instructions. The use of roof coverings requiring the application of heat during installation shall be reviewed and approved by a registered design professional.

4.2.9.2 Exterior Wall Covering:

Panels shall be covered on the exterior by a water-resistive barrier as required by the applicable code. The water-resistive barrier shall be attached with flashing in such a manner as to provide a continuous water-resistive barrier behind the exterior wall veneer. The exterior facing of the SIP wall shall be covered with weather protection as required by the adopted building code or other approved materials.

4.2.9.3 Interior Finish. The SIP foam plastic core shall be separated from the interior of the building by an approved thermal barrier of ½-inch (12.7 mm) gypsum wallboard or equivalent thermal barrier where required by IBC Section 2603.4.

5.0 CONDITIONS OF USE:

The Murus PUR SIPs described in this report comply with, or are suitable alternative to what is specified in, those codes listed in Section 1.0 of this report, subject to the following conditions:

- 5.1** Installation complies with this report and the approved construction documents.
- 5.2** This report applies only to the panel thicknesses specifically listed herein.
- 5.3** In-use panel heights/spans shall not exceed the values listed herein. Extrapolation beyond the values listed herein is not permitted.
- 5.4** The panels are manufactured in the production facility in Mansfield, Pennsylvania, under a quality control program with inspections by ICC-ES.

6.0 EVIDENCE SUBMITTED

Reports of axial load, transverse load, and in-plane racking shear tests of panels, conducted in accordance with general guidelines of ASTM E72.

7.0 IDENTIFICATION

- 7.1** The ICC-ES mark of conformity, electronic labeling, or the evaluation report number (ICC-ES ESR-4784) along with the name, registered trademark, or registered logo of the report holder must be included on the product label.
- 7.2** In addition, each Murus PUR SIP shall be identified by a stamp or label bearing the name and address of the manufacturer (The Murus Company) and the product or batch number, .
- 7.3** The report holder's contact information is the following:

THE MURUS COMPANY
POST OFFICE BOX 220
MANSFIELD, PENNSYLVANIA 16933
(570) 549-2100
www.murus.com

TABLE 1—BASIC PROPERTIES¹

Property	Strong-Axis Bending
Allowable Tensile Stress, F_t (psi)	495
Allowable Compressive Stress, F_c (psi)	619
Elastic Modulus (Bending), E_b (psi)	1,002,768
Shear Modulus, G (psi)	355
Allowable Core Shear Stress, F_v (psi)	6.5
Core Compressive Modulus, E_c (psi)	340
Reference Depth, h_o (in.)	4.625
Shear Depth Factor Exponent, m	0.977

For SI: 1 inch=25.4 mm; 1 psi= 6894.8 Pa.

¹ All properties are based on a minimum panel width of 24-in.

TABLE 2—SECTION PROPERTIES

Panel Thickness, h (in.)	Core Thickness, c (in.)	Dead Weight, w_d (psf)	Facing Area, A_f (in. ² /ft)	Shear Area, A_v (in. ² /ft)	Moment of Inertia, I (in. ⁴ /ft)	Section Modulus, S (in. ³ /ft)	Radius of Gyration, r (in.)	Centroid-to-Facing Dist., y_c (in.)
4.625	3.75	3.95	10.5	50.3	46.0	19.9	2.09	2.31
5.625	4.75	4.15	10.5	62.3	70.6	25.1	2.59	2.81
6.625	5.75	4.35	10.5	74.3	100.5	30.3	3.09	3.31

For SI: 1 inch= 25.4 mm; 1 foot= 304.8 mm; 1 psf=47.88 Pa; 1 in²/ft= 2116.66 mm²/m; 1 in³=16387.064 mm³; 1in⁴/ft=1365588.67 mm⁴/m

TABLE 3—OSB FACING MINIMUM PROPERTIES (ALONG THE MACHINE-AXIS)

Thickness (in.)	Flatwise Stiffness (lb-in. ² /ft)	Flatwise Strength (lb-in./ft)	Tension (lb/ft)	Density (pcf)
7/16	54,700	950	6,800	35

For SI: 1 inch= 25.4 mm; 1 foot= 304.8 mm; 1lbf=4.48 N; 1 pcf=0.006366 N/m³; 1 lbf-in/ft= 370.833 N-mm/m; 1 lbf/ft=14.59 N/m; 1 lbf-in²/ft=9419.167 N-mm/m

TABLE 4—ALLOWABLE UNIFORM TRANSVERSE LOADS (psf)^{1,3}

Span (ft)	4-5/8-in. thick SIP			5-5/8-in. thick SIP			6-5/8-in. thick SIP		
	Deflection Limit ²			Deflection Limit ²			Deflection Limit ²		
	L/180	L/240	L/360	L/180	L/240	L/360	L/180	L/240	L/360
4	175.5	131.6	87.8	222.6	166.9	111.3	247.6	202.3	134.8
6	105.5	79.1	52.7	134.3	102.2	68.1	141.5	125.4	83.6
8	69.5	52.2	34.8	91.7	68.8	45.8	99.0	85.7	57.1
10	48.1	36.1	24.1	64.8	48.6	32.4	76.2	61.5	41.0
12	34.5	25.8	17.2	47.2	35.4	23.6	60.7	45.5	30.3
14	25.3	19.0	12.7	35.3	26.5	17.6	45.9	34.5	23.0
16	19.0	14.3	9.5	26.9	20.2	13.4	35.4	26.6	17.7
18	14.6	10.9	7.3	20.9	15.6	10.4	27.8	20.8	13.9
20	11.3	8.5	5.7	16.4	12.3	8.2	22.1	16.5	11.0
22	9.0	6.7	4.5	13.1	9.8	6.6	17.8	13.3	8.9
24	7.2	5.4	3.6	10.6	8.0	5.3	14.5	10.8	7.2

For SI: 1 inch=25.4 mm; 1 foot=305 mm; 1 psf=47.88 Pa.

¹ Tabulated values assume a simply supported panel with minimum 1½-inch wide continuous bearing on facing at supports ($C_v = 1.0$) with solid wood plates at bearing locations. Values do not include the dead weight of the panel. For wall panel capacities utilizing a zero bearing configuration (Figure 2), the allowable load shall be determined using $C_v = 0.8$.

² Deflection limit shall be selected by building designer based on the serviceability requirements of the structure and the requirements of adopted building code. Values are based on loads of short duration only and do not consider the effects of creep.

³ Permanent loads, such as dead load, shall not exceed 0.50 times the tabulated load.

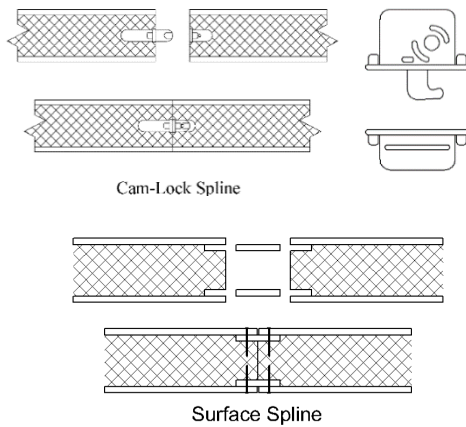

FIGURE 1—SIP SPLINE TYPES

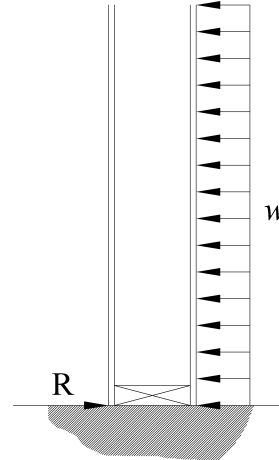

FIGURE 2—ZERO BEARING SUPPORT

TABLE 5—ALLOWABLE IN-PLANE SHEAR STRENGTH (POUNDS PER FOOT) FOR SIP SHEAR WALLS (WIND AND SEISMIC LOADS IN SEISMIC DESIGN CATEGORIES A, B AND C)^{1,2} (See Figure 3)

Spline Type ⁴	Minimum Nominal SIP Thickness (in.)	Minimum Facing Connections ^{2,4}			Shear Strength (plf)
		Chord ²	Plate ²	Spline ³	
Cam-lock	4-5/8 ⁶	0.131-in. x 2-1/2-in. coated nails, 6-in. on center	0.131-in. x 2-1/2-in. coated nails, 3-in. on center	Cam-locks spaced 24-in. on center	150
	4-5/8 ⁵	0.131-in. x 2-1/2-in. coated nails, 6-in. on center	0.131-in. x 2-1/2-in. coated nails, 3-in. on center	Cam-locks spaced 24-in. on center	360
	4-5/8 ⁶	0.131-in. x 2-1/2-in. coated nails, 6-in. on center	0.131-in. x 2-1/2-in. coated nails, 3-in. on center	Cam-locks spaced 24-in. on center Dow Great Stuff Pro® Insulating Foam Sealant (3) lines of 5/8-in. diameter bead at SIP joint	400
	4-5/8 ⁵	0.131-in. x 2-1/2-in. coated nails, 6-in. on center	0.131-in. x 2-1/2-in. coated nails, 3-in. on center	Cam-locks spaced 24-in. on center Dow Great Stuff Pro® Insulating Foam Sealant (3) lines of 5/8-in. diameter bead at SIP joint	475

For SI: 1 inch=25.4; 1 plf=14.6 N/m.

¹ Maximum shear wall dimensions ratio shall not exceed 2:1 (height: width) for resisting wind or seismic loads.
² Chords, hold downs and connections to other structural elements must be designed by a registered design professional in accordance with accepted engineering practice.
³ Spline type at interior panel-to-panel joints only. Solid chord members are required at each end of each shear wall segment.
⁴ Required connections must be made on each side of the panel. Dimensional or engineered lumber shall have an equivalent specific gravity of 0.42 or greater.
⁵ Assembly includes a second embedded bottom plate of 1-1/8-in. minimum thickness dimensional or engineered lumber with a specific gravity of 0.42 secured to the panel facing using 0.131-in. x 2-1/2-in. nails spaced 3-in. on center or an approved equivalent fastener and secured to the first bottom plate using #8 - 9 x 3-in. Wood Screws 6-in. on-center staggered. A second top plate of 1-1/8-in. minimum thickness dimensional or engineered lumber with a specific gravity of 0.42 that is cut to the full thickness of the panel shall be secured to the first top plate using #8 - 9 x 3-in. Wood Screws 6-in. on-center staggered.
⁶ A second top plate of 1-1/8-in. minimum thickness dimensional or engineered lumber with a specific gravity of 0.42 that is cut to the full thickness of the panel shall be secured to the first top plate using 0.162-in. x 3-1/2-in. nails or an approved equivalent fastener.

Section B: Top Cap Plate and Bottom Plate Fastener Details

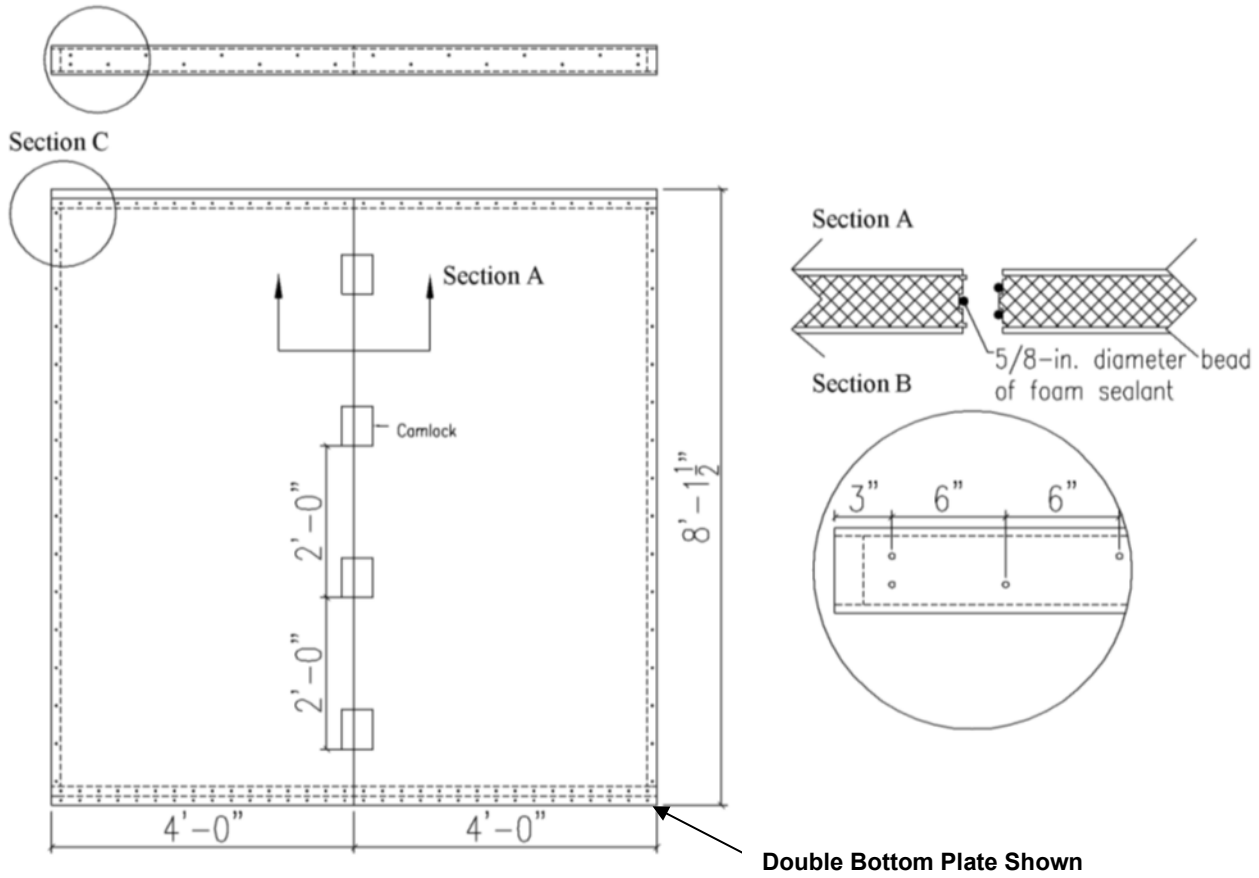

Double Bottom Plate Shown

Section C for Shear Wall with Single Bottom Plate

Section C for Shear Wall with Double Bottom Plate

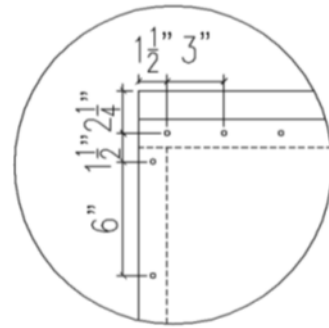
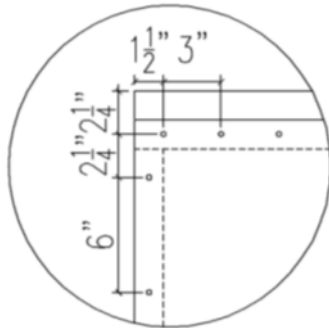

FIGURE 3—SHEAR WALL CONSTRUCTION DRAWING, SINGLE BOTTOM PLATE OR DOUBLE BOTTOM

TABLE 6—ALLOWABLE COMBINED AXIAL AND TRANSVERSE LOADS FOR 4-5/8-IN. THICKNESS SIPs^{1, 2, 3, 4, 5}

Uniform Transverse Load (psf)	Span (ft)								
	8	10	12	14	16	18	20	22	24
	Panel Dead Weight (plf)								
	28.2	35.2	42.3	49.3	56.4	63.4	70.5	77.5	84.6
	Allowable Axial Load (plf)								
0	4050	3640	3140	2690	--	--	--	--	--
10	3450 ^G	2970 ^G	2510 ^G	1980 ^E	--	--	--	--	--
25	2980 ^E	2110 ^D	1180 ^C	--	--	--	--	--	--
30	2760 ^D	1690 ^C	700 ^C	--	--	--	--	--	--
55	1070 ^C	--	--	--	--	--	--	--	--
60	730 ^B	--	--	--	--	--	--	--	--

For SI= 1 inch=25.4 mm; 1 ft= 305 mm; 1 plf=14.6 N/m; 1 psf=47.88 Pa.

¹ Permanent loads, such as dead load, shall not exceed 0.50 times the tabulated load.

² All values are for normal duration and may not be increased for other durations.

³ Axial loads shall be applied concentrically to the top of the panel through repetitive members spaced not more than 24-in. on center. Such members shall be fastened to a rim board or similar member to distribute along the top of the SIP.

⁴ The ends of both facings must bear on the supporting foundation or structure to achieve the tabulated axial loads.

⁵ When noted with the following superscript notes, values exceed the specified deflection ratio: ^AL/120, ^BL/180, ^CL/240, ^DL/360, ^EL/480, ^FL/600, ^GL/720. When the value is presented as a double dash (--), the value either is beyond the scope of the evaluation or exceeds the L/120 deflection ratio.

TABLE 7—ALLOWABLE COMBINED AXIAL AND TRANSVERSE LOADS FOR 5-5/8-IN. THICKNESS SIPs^{1, 2, 3, 4, 5}

Uniform Transverse Load (psf)	Span (ft)								
	8	10	12	14	16	18	20	22	24
	Panel Dead Weight (plf)								
	29.7	37.1	44.5	51.9	59.3	66.7	74.2	81.6	89
	Allowable Axial Load (plf)								
0	4300	4100	3860	3580	3260	--	--	--	--
10	3930 ^G	3560 ^G	3160 ^G	2760 ^G	2380 ^E	--	--	--	--
25	3500 ^F	3000 ^E	2460 ^D	1500 ^C	630 ^B	--	--	--	--
30	3370 ^E	2840 ^D	1980 ^C	950 ^C	--	--	--	--	--
55	2540 ^C	1000 ^B	--	--	--	--	--	--	--
60	2200 ^C	580 ^B	--	--	--	--	--	--	--

See [Table 6](#) for notes.

TABLE 8—ALLOWABLE COMBINED AXIAL AND TRANSVERSE LOADS FOR 6-5/8-IN. THICKNESS SIPs^{1, 2, 3, 4, 5}

Uniform Transverse Load (psf)	Span (ft)								
	8	10	12	14	16	18	20	22	24
	Panel Dead Weight (plf)								
	31.1	38.9	46.7	54.5	62.3	70	77.8	85.6	93.4
	Allowable Axial Load (plf)								
0	4440	4310	4140	3940	3710	3450	--	--	--
10	4170 ^G	3910 ^G	3590 ^G	3250 ^G	2900 ^G	2550 ^F	--	--	--
25	3820 ^G	3410 ^F	2950 ^E	2490 ^D	1760 ^C	860 ^C	--	--	--
30	3710 ^G	3250 ^E	2760 ^D	2190 ^C	1130 ^C	--	--	--	--
55	3210 ^D	2420 ^C	850 ^B	--	--	--	--	--	--
60	3110 ^D	2000 ^C	--	--	--	--	--	--	--

See [Table 6](#) for notes.