



ICC-ES Evaluation Report

ESR-4772

Reissued June 2023

This report is subject to renewal June 2024.

DIVISION: 03 00 00—CONCRETE
Section: 03 41 10—Precast Concrete Design

DIVISION 05 00 00—METALS
Section: 05 12 00—Structural Steel Framing

REPORT HOLDER:

SUPERIOR CONCRETE PRODUCTS

EVALUATION SUBJECT:

SUPERIOR CONCRETE PRODUCTS SCREEN SYSTEM—Superior Brick (SB), Superior Cobblestone (SCS), Superior Ledgestone (SLS), Superior Stucco (SST), Superior Wood Plus (SWP), Superior Board on Board (SBOB), Superior Fence (SF), and Superior Cut Stone (SCST)

1.0 EVALUATION SCOPE

Compliance with the following codes:

- 2021, 2018 and 2015 *International Building Code*® (IBC)
- 2021, 2018 and 2015 *International Residential Code*® (IRC)

For evaluation for compliance with codes adopted by the Los Angeles Department of Building and Safety (LADBS), see the [ESR-4772 LABC and LARC Supplement](#).

Property evaluated:

- Structural

2.0 USES

The Superior Concrete Products Screen System is a free-standing screen and/or partial retaining panel capable of resisting lateral out-of-plane wind, active soil pressure and seismic (generated by self-weight) loads. The Screen System are available in the following panel textures or patterns: Superior Brick (SB), Superior Cobblestone (SCS), Superior Ledgestone (SLS), Superior Stucco (SST), Superior Wood Plus (SWP), Superior Board on Board (SBOB), Superior Fence (SF), and Superior Cut Stone (SCST). See Figure 1 for product patterns and textures.

Under the IRC, an engineered design in accordance with IRC Section R301.1.3 must be submitted to the code official for approval.

3.0 DESCRIPTION

3.1 General:

The Superior Concrete Products Screen System consists of precast concrete stacked panels, posts, and caps. The stacked precast concrete panels are supported by precast concrete posts. Precast concrete panel caps and post caps are located at the top of the screen. The precast concrete panels are reinforced with one layer of galvanized 9-gauge wire mesh as illustrated in Figure 2. The precast concrete posts are reinforced with steel reinforcing and have molded tracks or grooves for the precast concrete panels to fit into as illustrated in Figures 3 and 4. Alternatively, structural steel with wide-flange sections may be used as a column in lieu of precast concrete posts to support stacked panels 20 feet tall and above as illustrated in Figure 5. Steel columns are supplied by others. The posts are embedded in the cast-in place concrete caisson foundations. Applications for drainage under the precast concrete panels is beyond the scope of this report.

For gravity loads, the panels are simply-supported, between the cast-in place concrete caissons. For lateral loads due to wind, seismic or soil pressure, the panels span horizontally out-of-plane between posts. The out-of-plane loads are transferred from the precast concrete panels through bearing to the precast concrete posts, and the posts resist lateral loads as cantilevered columns which are then transferred to the caisson foundation.

The cast-in-place concrete caisson foundations are outside the scope of this report.

3.1.1 Superior Concrete Products Precast Concrete Panels: The Superior Concrete Products precast concrete panels are 1 foot to 2 feet (0.30 m to 0.61 m) tall and 4.7 feet to 8 feet (1.43 m to 2.44 m) long reinforced with wire mesh reinforcing and must be designed in accordance with Section 4.1.2 of this report. The precast panels have textured or patterned finishes on both sides of the panel resembling wood and rock surfaces, stucco, brick masonry façade, etc.

The Superior Concrete Products Screen System is constructed of precast concrete panels stacked horizontally to create a solid privacy fence. Refer to Table 1 for additional information.

See Table 1 for nominal and design panel thicknesses and dimensions.

3.1.2 Superior Concrete Products Posts: The Superior Concrete Products precast concrete posts have solid square sections with molded tracks or grooves. See Table 1 for post dimensions. Posts are reinforced with steel reinforcing and are to be designed in accordance with Section 4.1.2 of this report.

As an alternative, structural steel wide-flange sections may be used in lieu of precast concrete posts. Structural steel angles are welded to the web of the wide-flange column to receive the panel ends. See Figure 3. Steel must be designed in accordance with Section 4.1.2 of this report.

3.1.3 Superior Concrete Products Precast Concrete Panel and Post Caps: Superior Concrete Products precast concrete panel caps are 2.5 inch to 4.625 inch thick (36.5 mm to 117.48 mm) and 4 inch to 6.25 inch wide (101.6 mm to 158.75 mm). The precast concrete panel caps are reinforced with steel reinforcing depending on the length of the element.

Superior Concrete precast post caps are secured to the top of the posts using a polyurethane sealant, per Section 3.2.2.

3.2 Materials:

3.2.1 Concrete: The Superior Concrete Products precast concrete panels and panel caps, and precast concrete posts and post caps are manufactured from normal-weight concrete with a minimum compressive strength of 5,000 psi (35 MPa) at 28-days.

3.2.2 Polyurethane Sealant (not supplied by Superior Concrete Products): Polyurethane sealant be approved for exterior use, must comply with ASTM C920 Type S, Grade NS, Class 25, use M and have a valid listing report.

3.2.3 Structural Steel (not supplied by Superior Concrete Products): Structural steel columns are hot rolled wide-flange W8x, W10x or W12x sections and comply with ASTM A992. Structural steel angles are hot-rolled and comply with ASTM A36.

3.2.4 Steel Reinforcing Bars: The deformed steel reinforcing bars are #4, #5 and #6 bars and must comply with ASTM A615 Grade 60 or ASTM A706 Grade 60.

3.2.5 Wire Mesh: Galvanized 9-gauge wire mesh must comply with ASTM A641 with a minimum yield strength, f_y , of 70,000 psi.

4.0 DESIGN AND INSTALLATION

4.1 Structural Design:

4.1.1 General:

The Superior Concrete Products Screen System must be designed to resist wind, seismic (generated by self-weight) and active soil pressure loads in accordance with the applicable sections of the IBC. Site-specific wind and seismic loads are to be determined in accordance with Section 1609 and 1613 of the IBC, respectively. Seismic loads must consider vertical seismic-induced forces.

The Superior Concrete Products Screen System must be designed by a registered design professional in accordance with Section 4.12.1 of ACI 318 (-19, -14), IBC Section 1807.1, 1901.2 and Section 4.1.2 of this report.

4.1.2 Engineering Design: Structural calculations in accordance with the applicable codes must be submitted to the code official for each screen system installation. Design calculations to be submitted must include the following:

- 1. Superior Concrete Products Precast Concrete Panels:** The precast concrete panels must be designed and detailed in accordance with applicable sections of ACI 318 and must satisfy the minimum reinforcing

required by code. The panel must be designed using strength design, both the ultimate strength and the cracked moment shall be checked for the governing strength. The total dead load of the panel must include the weight of the finish pattern. See Table 1. Refer to Figure 2 for placement of 9-gauge wire mesh. #5 steel reinforcing bars may be used in lieu of 9-gauge wire mesh where required by design.

Specified concrete cover must comply with Section 20.5.1.3 of ACI 318-19 or Section 20.6.1.3 of ACI 318-14.

Screen systems with partial retaining panels are limited to 4 feet (121.9 cm) tall with a maximum vertical surcharge of 50 psf (2394.01 N/m²).

- 2. Superior Concrete Products Posts:** The precast concrete posts must be designed as a cantilevered column to resist the lateral loads transferred from the precast concrete panels. The posts must be designed and detailed with #4 through #6 bars in accordance with applicable sections of ACI 318 and must satisfy the minimum reinforcing required by code. Refer to Figures 3 and 4 for reinforcing details.

Alternatively, when structural steel columns are used in lieu of precast concrete posts, steel columns must be designed as a cantilevered column to resist the lateral loads transferred from the precast concrete panels. The flexural and shear strength capacities must be determined in accordance with AISC 360.

- 3. Superior Concrete Products Precast Concrete Panel to Post Connection:** The lateral loads applied to the precast panels are transferred from the panel to the post through bearing of the end of the panel on a notch created by the molded track or groove in the precast concrete post. The shear capacity of the post notch must be designed and detailed in accordance with applicable sections of ACI 318.

Alternatively, when structural steel columns are used in lieu of precast concrete posts, the lateral loads applied to the precast panels are transferred to the steel column by bearing on the flange of the wide-flange beam in one direction and the leg of the steel angle in the other As illustrated in Figure 5. The connection must be designed and detailed in accordance with AISC 360.

- 4. Superior Concrete Products Post to Concrete Caisson Foundation Connection:** The post must be designed to transfer loads to the concrete caisson through embedment and is outside the scope of this report.

- 5. Concrete Caisson Foundations:** Concrete caissons and their reinforcing are beyond the scope of this report.

4.2 Installation:

4.2.1 General: Superior Concrete Products must be installed in accordance with the applicable code, this report, manufacturer's published installation instructions and the approved construction documents prepared by a registered design professional. A copy of the manufacturer's published installation instructions and the approved drawings must be available at all times on the jobsite during installation.

4.2.2 Precast Concrete Panel to Post Installation: Superior Concrete Products precast concrete panels are installed by sliding them down into molded tracks located in the precast concrete posts, creating a bearing connection between the panels and the posts. Panels may be dry stacked within the molded tracks of the precast concrete posts.

Gaps between the panel ends and the molded track or grooves in the precast concrete posts greater than $\frac{1}{16}$ inch (1.5 mm), must be filled polyurethane sealant in accordance with Section 3.2.2 of this report.

Alternatively, when precast concrete panels are supported by structural steel columns, the panels are slid down into the track between the steel column flange and the leg of the steel angle, creating a bearing connection between the panels and the steel.

4.2.3 Precast Concrete Post to Foundation Installation:

Precast concrete posts are to be embedded in the concrete caissons, per Section 4.1.2 of this report. The precast concrete post is set with a form and bolt clamp system. See Figure 6.

4.3 Special Inspection:

4.3.1 IBC: Special inspection, if required by the registered design engineer and must be in accordance with IBC Chapter 17.

4.3.2 IRC: For screens designed in accordance with the IBC for use under the IRC, special inspection in accordance with Section 4.3.1 is required.

5.0 CONDITIONS OF USE

The Superior Concrete Products Screen System described in this report complies with the codes listed in Section 1.0 of this report, subject to the following conditions:

5.1 The panels and posts must be installed in accordance with this report and the building plans approved by the code official.

5.2 Special inspection is required and must be in accordance with Section 4.3 of this report.

5.3 In areas where repeated freezing and thawing under saturated conditions occur, the registered design professional must verify the mix design is acceptable for freeze-thaw applications.

5.4 The Superior Concrete Products Screen System is manufactured under a quality control program with inspections by ICC-ES.

6.0 EVIDENCE SUBMITTED

6.1 Design calculations in accordance with ACI 318-19.

6.2 Quality documentation in accordance with ICC-ES Acceptance Criteria for Quality Documentation (AC10), dated January 2019.

7.0 IDENTIFICATION

7.1 Each Superior Concrete Products Screen System precast concrete panel and precast concrete post must be identified with the manufacturer's name, address, product type and evaluation report number (ESR-4772).

7.2 The report holder's contact information is the following:

SUPERIOR CONCRETE PRODUCTS

1203 RAIDER DRIVE

EULESS, TEXAS 76040

www.concretefence.com



Superior Brick



Superior Cobblestone

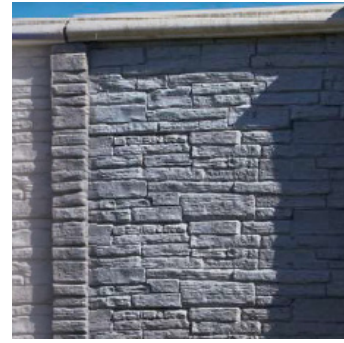

Superior LedgeStone

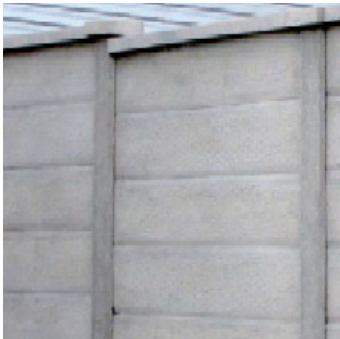

Superior Stucco



Superior Wood Plus

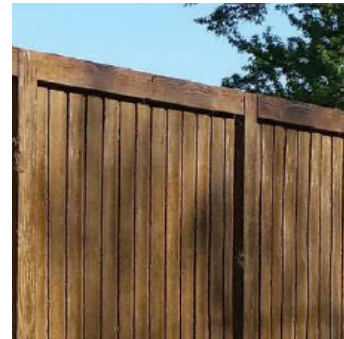

Superior Board on Board

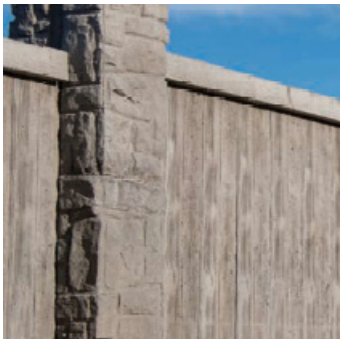

Superior Fence

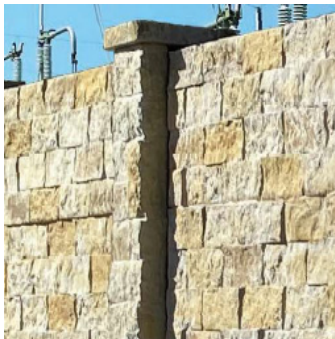

Superior Cut Stone

Figure 1: Product Types

Table 1: PANEL AND POST AVAILABLE DIMENSIONS

Product Name	PANEL					POST	
	Individual Panel Height	Individual Panel Length	Maximum Panel Thickness	Design Panel Thickness	Design Panel Weight	Max. Post Spacing ¹	Post Size
	(in)	(in)	(in)	(in)	(psf)	(ft)	(in x in)
Superior Brick (SB)	12	56.75	1.75	1.50	18.75	5.17	5x5 6.5x7
Superior Cobblestone (SCS)	12	56.75	1.75	1.41	17.63	5.17	5x5 7x7
Superior Ledgerstone (SLS)	12	56.75	1.75	1.49	18.63	5.17	5x5 7x7
Superior Stucco (SST)	12	56.75	1.75	1.75	21.88	5.17	5x5 7x7
Superior Wood Plus (SWP)	12	56.75	1.75	1.49	18.63	5.17	6x5.75
Superior Board on Board (SBOB)	12.5	66 or 90	2	1.77	22.13	7.33	6.25x6.125
Superior Fence (SF)	11.25	88.5	2	1.88	23.5	7.75	6.25x6.125
Superior Cut Stone (SCST)	24	88	6	5	62.5	8	12x14

FOR SI: 1 inch = 25.4 mm

¹ For fence systems with partial retaining walls, max post spacing must be reduced by 1/2.

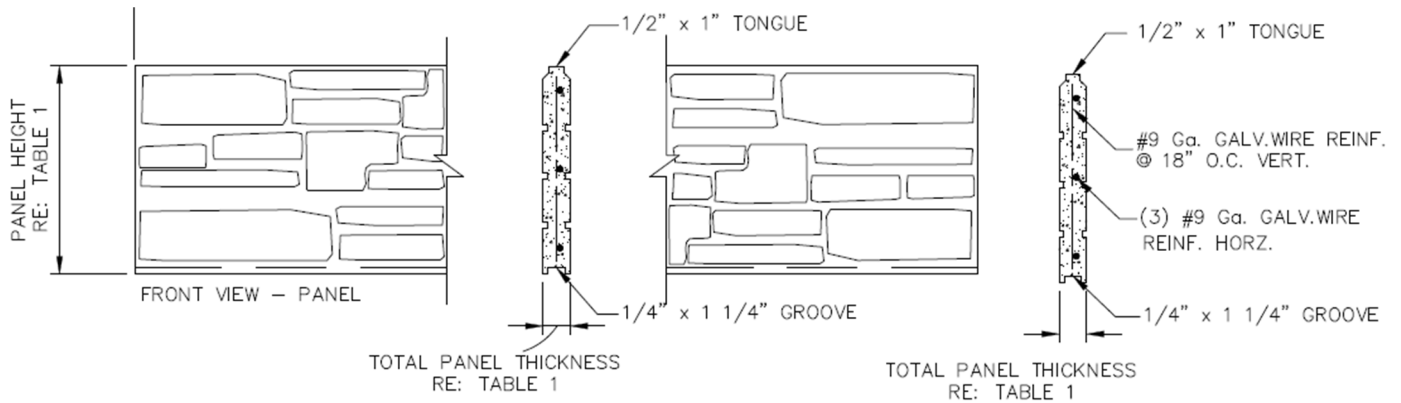

Figure 2: Typical Precast Panel Detail

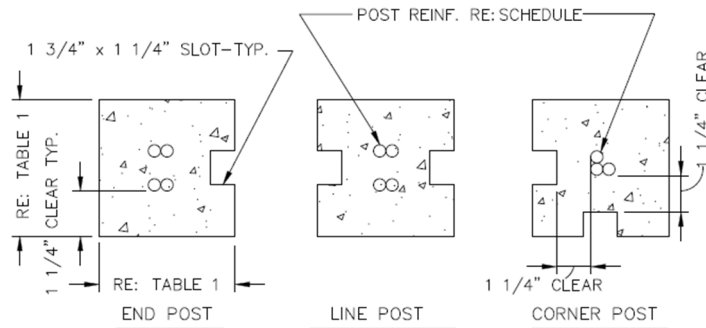

Figure 3: Typical Precast Post Detail

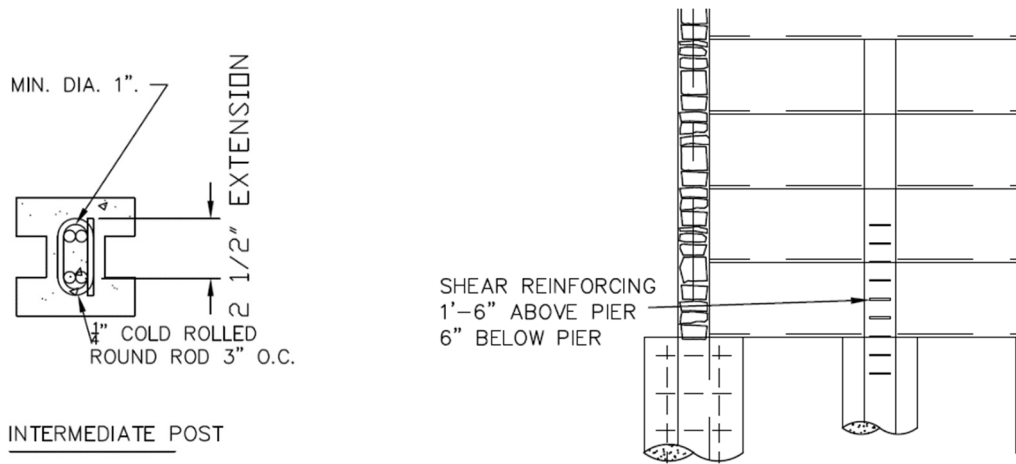
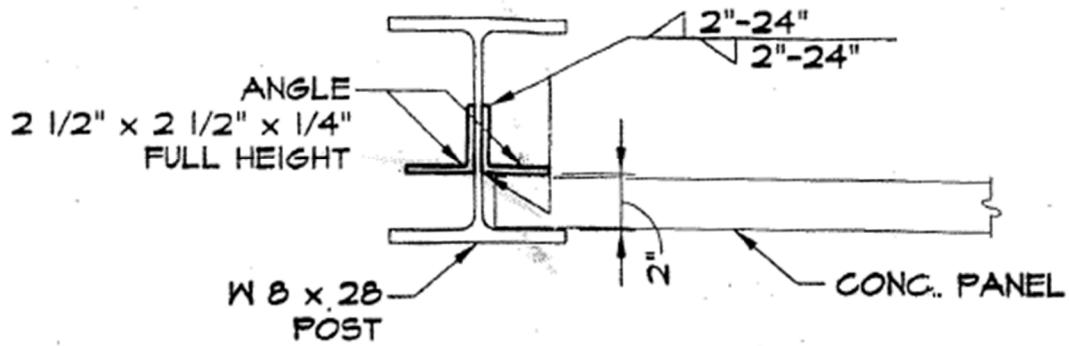

Figure 4: Typical Precast Post with Shear Reinforcing Detail and Elevation



NOTE: STRUCTURAL STEEL MEMBER SIZES SUBJECT TO CHANGE DEPENDING ON HEIGHT OF FENCE AND WIND/SEISMIC DEMAND.

Figure 5: Typical Precast Panel to Steel Column Detail - Plan View



Figure 6: Post to Foundation

DIVISION: 03 00 00—CONCRETE

Section: 03 41 10—Precast Concrete Design

DIVISION 05 00 00—METALS

Section: 05 12 00—Structural Steel Framing

REPORT HOLDER:

SUPERIOR CONCRETE PRODUCTS

EVALUATION SUBJECT:

SUPERIOR CONCRETE PRODUCTS SCREEN SYSTEM— Superior Brick (SB), Superior Cobblestone (SCS), Superior Ledgestone (SLS), Superior Stucco (SST), Superior Wood Plus (SWP), Superior Board on Board (SBOB), Superior Fence (SF), and Superior Cut Stone (SCST)

1.0 REPORT PURPOSE AND SCOPE**Purpose:**

The purpose of this evaluation report supplement is to indicate that Superior Concrete Products Wall System, described in ICC-ES evaluation report [ESR-4772](#), has also been evaluated for compliance with the codes noted below as adopted by the Los Angeles Department of Building and Safety (LADBS).

Applicable code editions:

- 2020 *City of Los Angeles Building Code* (LABC)
- 2020 *City of Los Angeles Residential Code* (LARC)

2.0 CONCLUSIONS

The Superior Concrete Products Wall System, described in Sections 2.0 through 7.0 of the evaluation report [ESR-4772](#), complies with the LABC Chapter 19 and 22, and the LARC, and is subject to the conditions of use described in this supplement.

3.0 CONDITIONS OF USE

The Superior Concrete Products Wall System described in this evaluation report supplement must comply with all of the following conditions:

- All applicable sections in the evaluation report [ESR-4772](#).
- The design, installation, conditions of use and identification of the Superior Concrete Products Wall System are in accordance with the 2018 *International Building Code*® (IBC) provisions noted in the evaluation report [ESR-4772](#).
- The design, installation and inspection are in accordance with additional requirements of LABC Chapters 16, 17 19 and 22, as applicable.
- Under the LARC, an engineered design in accordance with LARC Section R301.1.3 must be submitted.

This supplement expires concurrently with the evaluation report, reissued June 2023.

DIVISION: 03 00 00—CONCRETE

Section: 03 41 10—Precast Concrete Design

DIVISION 05 00 00—METALS

Section: 05 12 00—Structural Steel Framing

REPORT HOLDER:

SUPERIOR CONCRETE PRODUCTS

EVALUATION SUBJECT:

SUPERIOR CONCRETE PRODUCTS SCREEN SYSTEM— Superior Brick (SB), Superior Cobblestone (SCS), Superior Ledgestone (SLS), Superior Stucco (SST), Superior Wood Plus (SWP), Superior Board on Board (SBOB), Superior Fence (SF), and Superior Cut Stone (SCST)

1.0 REPORT PURPOSE AND SCOPE**Purpose:**

The purpose of this evaluation report supplement is to indicate that the Superior Concrete Products Wall System, described in ICC-ES evaluation report ESR-4772, has also been evaluated for compliance with the code(s) noted below.

Applicable code edition(s):

- 2019 *California Building Code* (CBC)

For evaluation of applicable chapters adopted by the California Office of Statewide Health Planning and Development (OSHPD) AKA: California Department of Health Care and Information (HCAI) and the Division of State Architect (DSA), see Sections 2.1.1 and 2.1.2 below.

- 2019 *California Residential Code* (CRC)

2.0 CONCLUSIONS**2.1 CBC:**

The Superior Concrete Products Wall System, described in Sections 2.0 through 7.0 of the evaluation report ESR-4772, complies with CBC Chapters 19 and 22, provided the design and installation are in accordance with the 2018 *International Building Code*® (IBC) provisions noted in the evaluation report and the additional requirements of Chapter 16 and 17, as applicable.

2.1.1 OSHPD: The applicable OSHPD Chapters and Sections of the CBC are beyond the scope of this supplement.

2.1.2 DSA: The applicable DSA Chapters and Sections of the CBC are beyond the scope of this supplement.

2.2 CRC:

The Superior Concrete Products Wall System, described in Sections 2.0 through 7.0 of the evaluation report ESR-4772, complies with the CRC, provided the design and installation are in accordance with the 2018 *International Residential Code*® (IRC) provisions noted in the evaluation report.

This supplement expires concurrently with the evaluation report, reissued June 2023.

DIVISION: 03 00 00—CONCRETE

Section: 03 41 10—Precast Concrete Design

DIVISION 05 00 00—METALS

Section: 05 12 00—Structural Steel Framing

REPORT HOLDER:

SUPERIOR CONCRETE PRODUCTS

EVALUATION SUBJECT:

SUPERIOR CONCRETE PRODUCTS SCREEN SYSTEM— Superior Brick (SB), Superior Cobblestone (SCS), Superior Ledgestone (SLS), Superior Stucco (SST), Superior Wood Plus (SWP), Superior Board on Board (SBOB), Superior Fence (SF), and Superior Cut Stone (SCST)

1.0 REPORT PURPOSE AND SCOPE**Purpose:**

The purpose of this evaluation report supplement is to indicate that the Superior Concrete Products Wall System, described in ICC-ES evaluation report ESR-4772, has also been evaluated for compliance with the codes noted below.

Applicable code editions:

- 2020 Florida Building Code—Building
- 2020 Florida Building Code—Residential

2.0 CONCLUSIONS

The Superior Concrete Products Wall System, described in Sections 2.0 through 7.0 of ICC-ES evaluation report ESR-4772, complies with the *Florida Building Code—Building* and the *Florida Building Code—Residential*, provided the design requirements are in accordance with the *Florida Building Code—Building* or the *Florida Building Code—Residential*, as applicable. The installation requirements noted in ICC-ES evaluation report ESR-4772 for the 2018 *International Building Code*® meet the requirements of the *Florida Building Code—Building* or the *Florida Building Code—Residential*.

Use of the Superior Concrete Products Wall System for compliance with the High-Velocity Hurricane Zone provisions of the *Florida Building Code—Building* or the *Florida Building Code—Residential* has not been evaluated, and is outside the scope of this supplemental report.

For products falling under Florida Rule 61G20-3, verification that the report holder's quality assurance program is audited by a quality assurance entity approved by the Florida Building Commission for the type of inspections being conducted is the responsibility of an approved validation entity (or the code official when the report holder does not possess an approval by the Commission).

This supplement expires concurrently with the evaluation report, reissued June 2023.