

ICC-ES Evaluation Report

ESR-4735

Reissued October 2024

This report also contains:

- CA Supplement

Subject to renewal October 2026

- FL Supplement

ICC-ES Evaluation Reports are not to be construed as representing aesthetics or any other attributes not specifically addressed, nor are they to be construed as an endorsement of the subject of the report or a recommendation for its use. There is no warranty by ICC Evaluation Service, LLC, express or implied, as to any finding or other matter in this report, or as to any product covered by the report.

Copyright © 2024 ICC Evaluation Service, LLC. All rights reserved.

<p>DIVISION: 31 00 00— EARTHWORK</p> <p>Section: 31 63 00— Bored Piles</p>	<p>REPORT HOLDER:</p> <p>PIEUX VISTECH/POSTECH SCREW PILES, INC</p>	<p>EVALUATION SUBJECT:</p> <p>POSTECH SCREW PILE FOUNDATION SYSTEM</p>	
--	---	--	---

1.0 EVALUATION SCOPE

Compliance with the following codes:

- 2021, 2018, 2015, 2012, and 2009 [International Building Code® \(IBC\)](#)
- 2021, 2018, 2015, 2012, and 2009 [International Residential Code® \(IRC\)](#)

Properties evaluated:

- Structural
- Geotechnical

2.0 USES

2.1 IBC:

Under the IBC, the Postech Screw Pile foundation system are used either to underpin foundations of existing structures or to form deep foundations for new structures; and are designed to transfer axial compression, axial tension, and lateral loads from the supported structures to suitable soil-bearing strata.

2.2 IRC:

Under the IRC, Postech Screw Pile foundation system may be used as an alternate foundation system supporting light-frame construction, exterior porch deck, elevated walkway and stairway construction and accessory structures.

3.0 DESCRIPTION

3.1 General:

The Postech Screw Pile foundation system consists of a helical pile and a bracket that allows for attachment to the supported structures. Each helical pile, consisting of a lead section and one or more extension sections (optional), is screwed into the ground, by application of torsion, to a depth that conforms to project requirements for avoidance of unsatisfactory subsurface conditions and that ensures a suitable soil- or bedrock-bearing stratum has been reached. The bracket is then installed to connect the pile to the supported structure.

3.2 System Components:

3.2.1 Lead and Extension Shafts (P312): The Postech lead sections consist of single helical-shaped circular steel plates (helix plates) welded to a central steel shaft. The depth of the helical piles in soil is typically extended by adding one or more steel shaft extensions that are mechanically connected together by welded steel couplings, to form one continuous steel pile. The extensions do not include helical bearing plates. Both

the lead section and the extension sections are round hollow structural steel sections, HSS3.500x0.216, measuring from 3-to-10 feet (0.91 to 3.05 m) long and having a 3¹/₂-inch (88.9 mm) outside diameter and a 0.216-inch (5.5 mm) nominal wall thickness. The leading end of a lead section is cut to a 45° angle from the shaft longitudinal axis. [Figures 1](#) and [2](#) illustrate a typical helical pile lead section and an extension, respectively.

3.2.2 Helix Plates: Each circular, helical, steel bearing plate (helix) is split from the center to the outside edge with spiral edge geometry. Each helix is formed to a clockwise downward spiral with all radial sections normal to the shaft's central longitudinal axis and with a 3.5-inch (89 mm) pitch. The pitch is the distance between the leading and the trailing edge. The helix plates are factory-welded and have an outer diameter of 10, 12, 14, 16 and 18 inches (254, 305, 356, 406 and 457 mm). The helical plates are made from ³/₈-and-¹/₂-inch (10 and 12.7 mm) thick steel. See [Figure 1](#) for helical pile configurations.

3.2.3 Couplings: The coupling is factory-welded to the bottom end of an extension section. The coupling consists of a round HSS4.000x0.226, with an outside diameter of 4.0 inches (101.6 mm), and a 0.226-inch (5.74 mm) nominal wall thickness. Two holes are drilled in the coupling and these holes are aligned with the two holes drilled in the lead section or extension to receive two (2) through ³/₄-inch-diameter (19 mm) bolts.

3.2.4 Brackets: The Postech brackets are either Type A (repair) or Type B (direct load) brackets as defined in Sections 3.10.1 and 3.10.2 of AC358, respectively.

3.2.4.1 Underpinning (Repair) Bracket (Type A bracket): The underpinning bracket assembly is designed for use with the P312 helical shaft and is used to transfer axial compressive loading from existing concrete foundations to the P312 helical piles. The bracket assembly consists of a bracket, a steel tube, and two threaded rods and matching nuts. (See [Figure 3](#)).

3.2.4.2 Type B (direct load) Brackets:

3.2.4.2.1 Concrete Fixed Head Brackets: These brackets are used to support new concrete foundations, and are for attaching to helical piles that support axial compression, axial tension and lateral loads. Each bracket consists of one steel cap plate and one steel tube sleeve, which are factory-welded together to form the bracket. The cap plates come in 6-inch-square (152 mm-square) and 8-inch-square (203 mm-square) dimensions, ⁵/₁₆ inch (7.9 mm) thick. The tubular sleeves of the brackets are round HSS2.875x0.203, measuring 3.5 inches (89 mm) in length and having a 2.875-inch (73 mm) outside diameter and a 0.203-inch (5.2 mm) nominal wall thickness. The steel sleeve has one (1) ¹³/₁₆-inch-diameter (20.6 mm) hole, allowing the sleeve and the top of the helical shaft section to be through-bolted together using ³/₄-inch-diameter (19 mm) bolt during the field installation. [Figure 5](#) provides bracket dimensions. [Tables 6A](#) and [6B](#) provide bracket allowable capacities and requirements for the attached concrete foundations. The concrete covers, including dimensions and concrete strength, must comply with what is prescribed in [Table 6C](#).

3.2.4.2.2 U-Shape Fixed Head Bracket: These brackets are used to support wood beams and wood columns or posts in new or existing construction, and are for helical piles that support axial compression and axial tension loads. The brackets are U-shaped steel bent plates that are factory-welded to the top of a steel sleeve. Each bracket comes with two drilled holes, on each vertical plate (side plate), to allow the attachment of supported wood beam or column using through bolts. The U-shaped fixed head are made from ¹/₄-inch (6.4 mm) thick steel and comes in several lengths from 4⁵/₈ to 8¹/₈ inches (117 to 206 mm) long, with the bracket length measured in the beam length direction. The steel sleeve is round HSS4.000x0.226, with an outside diameter of 4.0 inches (101.6 mm), and a 0.226-inch nominal wall thickness. The steel sleeve comes with drilled holes used to connect the bracket to the top of the helical shaft using bolts. See [Figure 4](#) for bracket configurations and construction.

3.3 Material Specifications:

3.3.1 Lead and Extension Shafts: The shaft lead and extension sections are carbon steel round HSS conforming to ASTM A500, Grade C, except having a minimum yield strength of 50 ksi (345 MPa) and a minimum tensile strength of 65 ksi (448 MPa). The shaft finish is either plain steel or hot-dip galvanized in accordance with ASTM A123.

3.3.2 Helix Plates: The helix plates are carbon steel conforming to CSA G40-21-50W, having a minimum yield strength of 50 ksi (345 MPa) and a minimum tensile strength of 65 ksi (448 MPa). The helix plates and the shafts to which they are factory-welded are either plain finish or hot-dipped galvanized as assemblies in accordance with ASTM A123.

3.3.3 Couplings: The coupling, reinforced coupling and expanded coupling are carbon steel round HSS sections conforming to ASTM A500, Grade C, except having a minimum yield strength of 50 ksi (345 MPa) and a minimum tensile strength of 65 ksi (448 MPa). The coupling finish is either plain steel or hot-dipped galvanized in accordance with ASTM A123.

3.3.4 Underpinning (Repair) Bracket: The bracket plates and steel tubing made from carbon steel conforming to CSA G40-21-50W, having a minimum yield strength of 50 ksi (345 MPa) and a minimum tensile strength of 65 ksi (448 MPa). Threaded rods comply with ASTM A307 with matching nuts complying with ASTM A563. The brackets finish is either plain finish or hot-dipped galvanized in accordance with ASTM A123.

3.3.4.1 Underpinning (Repair) Bracket Anchor Bolts: The adjustable head support bracket must be installed by connecting the bracket to the concrete foundation using two $\frac{3}{4}$ -inch-diameter (19 mm) by $5\frac{1}{2}$ -inch-long (140 mm) Hilti Kwik Bolt TZ ([ESR-1917](#)) or equivalent as determined by registered design professional.

3.3.5 U-Shape Fixed Head Brackets: The cap plates of the fixed-head brackets cap and bent plates, are carbon steel conforming to CSA G40-21-50W, except having a minimum yield strength of 50 ksi (345 MPa) and a minimum tensile strength of 65 ksi (448 MPa). The tubular sleeves of the fixed head brackets are carbon steel round HSS conforming to ASTM A500, Grade C, except having a minimum yield strength of 50 ksi (345 MPa) and a minimum tensile strength of 65 ksi (448 MPa). For the through-bolted connection between a bracket sleeve and a pile shaft as required for the brackets, the bolt must comply with SAE J429 Grade 5 or ASTM F3125 Grade A325, with a minimum tensile strength of 120 ksi (827 MPa); the nut must comply with SAE J995, Grade 5 or ASTM A563, Type DH3;. The finish of the bolt and nut must be plain steel or hot-dipped galvanized coating complying with ASTM A153. The bracket finish is either plain steel or hot-dipped galvanized in accordance with ASTM A123.

4.0 DESIGN AND INSTALLATION

4.1 Design:

4.1.1 General: Engineering calculations (analysis and design) and drawings, prepared by a registered design professional, must be submitted to and approved by the code official for each project, and must be based on accepted engineering principles as described in IBC Section 1604.4, and must conform to Section 1810 of the IBC. Under the IRC, the registered design professional must design the helical pile system and devices, including the bracket, used as a foundation element. The applied loads must not exceed the published capacities shown in this report for the helical pile system and devices. The registered design professional may determine the design forces in accordance with IRC Section R301 or, as an alternate, in accordance with IBC provisions. The engineering analysis must address helical foundation system performance related to structural and geotechnical requirements. The calculations must address the ability (considering strength and stiffness) of the supported foundation and structure to transmit the applied loads to the helical foundation system and the ability of the helical piles and surrounding soils to support the loads applied by the supported foundation and structure. The design method for the steel components is Allowable Strength Design (ASD), described in AISC 360 Section B3. The design method for the concrete components is Strength Design (also called LRFD) as described in ACI 318, and must comply with Section 3.7.1.2 of AC308 in order to utilize the ASD capacities described in this evaluation report. The design method for soils is ASD as prescribed in IBC Sections 1801.2.

The structural analysis must consider all applicable internal forces (axial forces, shears, bending moments and torsional moments, if applicable) due to applied loads; eccentricity between applied loads and reactions acting on the pile-supported structure; the loading exerted on the supported structure by the connection brackets; and the design span(s) between helical foundations. The loading exerted on the supported structure by the connection bracket is equal in magnitude and opposite in direction to the force in the pile. A small lateral force is developed at the supported structure if the pile shaft is not perfectly plumb but within the permitted inclination from vertical of $\pm 1^\circ$. The lateral force is equal to 0.0175 times the axial force in the pile, and must be resisted by the supported structure or other structures that are connected to the supported structure. The result of this analysis and the structural capacities must be used to select a helical foundation system.

The minimum pile embedment into soil for various loading conditions must be determined based on the most stringent requirements of the following: engineering analysis; tested conditions and specified minimum pile embedment described in this report; the site-specific geotechnical investigation report; and site-specific load tests, if applicable.

For helical foundation systems subject to combined lateral and axial (compression or tension) loads, the allowable strength of the shaft under combined loads must be determined using the interaction prescribed in Chapter H of AISC 360.

The geotechnical analysis must address the suitability of the helical foundation system for the specific project. It must also address the center-to-center spacing of the helical pile, considering both effects on the supported foundation and structure and group effects on the pile-soil capacity. The analysis must include estimates of the axial tension, axial compression and lateral capacities of the helical piles, whatever is relevant for the project, and the expected total and differential foundation movements due to single pile or pile group, as applicable.

A written report of the geotechnical investigation must be submitted to the code official as part of the required submittal documents, prescribed in IBC Section 107, at the time of the permit application. Under the IRC, a site-specific soil investigation report is not required if the helical pile system described in the evaluation report is being installed to support IRC structures defined in Section 2.2 of this report and the soil capacity of the helical pile is established in accordance with Equation 3 in Section 4.1.5 of this report. The geotechnical report must include, but not be limited to, the following information:

1. A plot showing the location of the soil investigation.
2. A complete record of the soil boring and penetration test logs and soil samples.
3. A record of the soil profile.
4. Information on groundwater table, frost depth and corrosion-related parameters, as described in Section 5.0 of this report.
5. Soil design parameters, such as shear strength, soil bearing pressure, unit weight of soil, deformation characteristics and other parameters affecting pile-support conditions as defined in IBC Section 1810.2.1.
6. Confirmation of the suitability of helical foundation systems for the specific project.
7. Recommendations for design criteria, including but not limited to, mitigation of effects of differential settlement and varying soil strength; and effects of adjacent loads.
8. Recommended center-to-center spacing of helical pile foundations, if different from spacing noted in Section 5.0 of this report; and reduction of allowable loads due to the group action, if necessary.
9. Field inspection and reporting procedures (to include procedures for verification of the installed bearing capacity, when required).
10. Load test requirements.
11. Any questionable soil characteristics and special design provisions, as necessary.
12. Expected total and differential settlement.
13. The axial compression, axial tension and lateral load soil capacities if values cannot be determined from this evaluation report.

There are four primary structural/geotechnical elements associated with the helical foundation system: bracket capacity, pile shaft capacity, helix plate capacity and soil capacity, which are described in Sections 4.1.2, 4.1.3, 4.1.4, and 4.1.5, respectively. The allowable capacity of overall helical foundation system is described in Section 4.1.6.

4.1.2 Bracket Capacity:

The supported structural elements connecting the bracket to the helical pile shaft must be designed and justified to the satisfaction of the code official. Only localized limit states related to interaction of the bracket and supported structural element have been evaluated for this evaluation report. For brackets resisting axial tension (uplift) loading, the connection between wood screws and wood beam must be designed and detailed to provide additional mechanical reinforcement capable of transmitting all of the stresses that would otherwise need to be transmitted through tension perpendicular to grain within the wood members. Other limit states are outside the scope of this report. Under Seismic Design Categories D, E and F, the bracket must be designed in accordance with IBC Section 1810.3.11.2. Refer to [Tables 4, 5A](#) through [5E](#) and [6A](#) through [6B](#) for bracket allowable axial compression, axial tension and lateral load capacities, as applicable.

4.1.3 Shaft Capacity: The top of the shafts must be braced, as prescribed in IBC Section 1810.2.2, and the supported structures such as concrete footings and wood beams are assumed to be adequately braced such that the supported structures provide lateral stability for the pile systems. In accordance with IBC Section 1810.2.1, any soil other than fluid soil must be deemed to afford sufficient lateral support to prevent buckling of the systems that are braced, and the unbraced length is defined as the length of piles standing in air, water, or in fluid soils plus an additional 5 feet (1524 mm) when embedment is into firm soil, or an additional 10 feet (3048 mm) when embedment is into soft soil. Firm soils are defined as soils with a Standard Penetration Test (SPT) blow count of five or greater. Soft soils are defined as soils with an SPT blow count greater than zero and less than five. Fluid soils are defined as soils with an SPT blow count of zero [weight of hammer (WOH) or weight of rods (WOR)]. Standard Penetration Test blow count must be determined in accordance with ASTM D1586. Under the IRC, when helical pile shafts are fully embedded into soil conditions defined in IRC Table R401.4.1 the helical pile shafts are deemed adequately supported to prevent buckling. The shaft capacity of the helical foundation systems is reported in [Table 7](#) of this report. For shaft capacities not reported in [Table 7](#), these capacities must be determined by registered design professional.

The elastic shortening/lengthening of the pile shaft will be controlled by the strength and section properties of the 3.5-inch-diameter (89 mm) shaft sections and the coupler(s), as applicable. The elastic deflection of the piling will be limited to the following:

- For Plain Steel:
 - 0.000241 inch per lineal foot of shaft length per kip of axial load (0.00451 mm per lineal meter of shaft length per kN of axial load) plus 0.000189 inch per coupler per kips of axial load (0.00479 mm per coupler per kN of axial load).
 - 0.161 inch (4.09 mm) per coupler slip
- For Galvanized Steel:
 - 0.000199 inch per lineal foot of shaft length per kip of axial load (0.00372 mm per lineal meter of shaft length per kN of axial load) plus 0.000154 inch per coupler per kips of axial load (0.00392 mm per coupler per kN of axial load).
 - 0.132 inch (3.35 mm) per coupler slip

The mechanical properties of the shaft sections are shown in [Table 3](#) and can be used to calculate the anticipated settlements due to elastic shortening/lengthening of the pile shaft.

4.1.4 Helix Plate Capacity: The helix plate allowable axial compression and tension capacities are listed in [Table 8](#).

4.1.5 Soil Capacity: The design axial compressive and tensile load capacities of helical piles based on soil resistance must be determined by a registered design professional in accordance with a site-specific geotechnical report, as described in Section 4.1.1, combined with the individual helix bearing method (Method 1), or from field loading tests conducted under the supervision of a registered design professional, as applicable (Method 2). For either Method 1 or Method 2, the predicted axial load capacities must be confirmed during the site-specific production installation, such that the allowable axial load capacities predicted by the torque correlation method must be equal to or greater than that predicted by Method 1 or 2, described above.

With the individual helix bearing method, the nominal axial load capacity of the helical pile is determined as the area of the helical bearing plate times the ultimate bearing capacity of the soil or rock bearing strata for the plate. Under the 2021 IBC, the axial capacity is equal to the sum of the areas of the helical bearing plates times the ultimate bearing capacity of the soil or rock comprising the bearing stratum plus the shaft resistance. The shaft resistance is equal to the area of the shaft above the uppermost helical bearing plate times the ultimate skin resistance.

The design allowable axial load must be determined by dividing the ultimate axial load capacity predicted by either Method 1 or 2, above, by a safety factor of at least 2.

Under the IRC, if the helical pile system is being installed to support structures governed by the IRC as defined in Section 2.2 of this report, and a site-specific geotechnical report is not available, a FOS of 2.5 must be used with the torque correlation method in lieu of Method 1 or 2 to determine allowable soil capacity of the pile (Equation 3).

With the torque correlation method, the ultimate and allowable axial load capacities of the helical pile are predicted as follows:

$$Q_{ult} = K_t T \quad (\text{Eq. 1})$$

$$Q_{all} = 0.5 Q_{ult} \quad (\text{Eq. 2})$$

$$Q_{all} = 0.4 Q_{ult} \quad (\text{Eq. 3})$$

where:

Q_{ult} = Ultimate axial tensile or compressive capacity (lbf or N) of the helical pile.

Q_{all} = Allowable axial tensile or compressive capacity (lbf or N) of the helical pile.

K_t = Torque correlation factor of 7 ft^{-1} (23.0 m^{-1}) in compression and of 7 ft^{-1} (19.7 m^{-1}) in tension for the $3\frac{1}{2}$ -inch-outside-diameter (88.9 mm) round shaft.

T = Final installation torque in ft-lbf or N-m, which must not exceed the maximum installation torque prescribed in [Tables 1](#) and [2](#).

The maximum ultimate and maximum allowable axial compression and tension capacities predicted by the torque-correlation method are less than or equal to those axial verification test results. The smaller of the torque-correlation predicted maximum axial capacities (ultimate and allowable) and the axial verification test results are provided in [Tables 1](#) and [2](#), on soil capacities.

The lateral capacity of the pile referenced in [Table 9](#) of this report is based on field testing of the helical pile with a 10-inch-diameter (254 mm) single helix plate installed in a very stiff clay soil with a minimum SPT blow count of 26 at a minimum embedment of 15 feet (4.6 m). For soil conditions other than very stiff clay, the lateral capacity of the pile must be determined by a registered design professional.

4.1.6 Helical Pile Foundation System: The overall allowable axial capacity of the Postech Screw Pile foundation system (in axial tension and axial compression) depends upon the analysis of interaction of brackets, shafts, helical plates and soils, and must be the lowest value of those for bracket capacity, shaft capacity, helical bearing plate capacity and allowable soil capacity. The overall allowable lateral capacity of the Postech helical foundation system depends upon the analysis of interaction of brackets, shafts, and soils, and must be the lowest value of those for bracket capacity, shaft capacity, and allowable soil capacity.

4.1.7 Foundation System: The additional requirements noted in this section (Section 4.1.7) must be satisfied. For all design methods permitted under Section 4.1.1 of this report, the allowable axial compressive and tensile load of the helical pile system must be based on the least of the following conditions in accordance with IBC Section 1810.3.3.1.9:

- Allowable load predicted by the individual helix bearing method (or Method 1) described in Section 4.1.5 of this report.
- Allowable load predicted by the torque correlation method described in Section 4.1.5 of this report.
- Allowable load predicted by dividing the ultimate capacity determined from load tests (Method 2 described in Section 4.1.5) by a safety factor of at least 2.0. This allowable load will be determined by a registered design professional for each site-specific condition. Under the 2021 IBC, the load tests must comply with 2021 IBC Section 1810.3.3.1.2.
- Allowable capacities of the shaft and shaft couplings. See Section 4.1.3 of this report.
- Allowable axial load capacity of the bracket. See Section 4.1.2 of this report.

4.2 Installation:

4.2.1 General: The Postech Screw Pile foundation system must be installed in accordance with this section (Section 4.2) IBC Section 1810.4.11, the site-specific approved construction documents (engineering plans and specifications), and the manufacturer's written installation instructions. In case of a conflict, the most stringent governs. The Postech Screw Pile foundation system must be installed only by Postech Screw Pile, Inc. trained and certified installers.

The bolts used to connect the coupler to extension and bracket sleeve to the pile shaft must be tightened to achieve a snug-tight condition as defined in Section J3 of AISC 360.

4.3 Special Inspections:

4.3.1 IBC:

Special inspection in accordance with Section 1705.9 of the 2021, 2018, 2015 and 2012 IBC (Section 1704.10 for the 2009 IBC) must be performed continuously during the installation of the Postech screw pile foundation systems (piles and brackets). Where on-site welding is required, inspection in accordance with IBC Section 1705.2 of the 2021, 2018, 2015 and 2012 IBC (Section 1704.3 for the 2009 IBC) is also required. Items to be recorded and confirmed by the special inspector include, but are not limited to, the following:

1. Verification of the product manufacturer and the manufacturer's certification of installers.
2. Product configuration and identification (including catalog numbers) for lead sections, extension sections, and brackets.
3. Installation equipment used.
4. Written installation procedures.
5. Bolts, nuts and washers as specified in the approved construction documents and this evaluation report.
6. Fielding cutting, bolting and welding as specified in the approved construction documents and this evaluation report.
7. Inclination and position of helical piles.
8. Tip elevations, installation torque and depth of helical piles.
9. Compliance of the installation with the approved construction documents and this evaluation report, including conditions and limitations described in the footnotes to the tables in this report.

5.0 CONDITIONS OF USE:

The Postech Screw Pile foundation system described in this report comply with, or is a suitable alternatives to what is specified in, those codes noted in Section 1.0 of this report, subject to the following conditions:

- 5.1** The Postech Screw Pile foundation system is manufactured, identified and installed in accordance with this report, the approved construction documents (engineering drawings and specifications), and the manufacturer's written installation instructions, which must be available at the jobsite at all times during installation. In case of a conflict, the most stringent requirement governs.
- 5.2** The Postech Screw Pile foundation system has been evaluated for support of structures assigned to Seismic Design Categories (SDCs) A through F in accordance with IBC; and SDCs A through C, D through D2 and E in accordance with the IRC. Anchorage of brackets to foundation or supported structural supported element must be designed by a registered design professional for each project in accordance with Section 5.3 of this report and subject to approval by the code official.
- 5.3** When installed in Seismic Design Categories D, E and F under the IBC; and D through D2 and E under the IRC, the following conditions must be considered:
 - a. The strength of the top bracket connection to the shaft and to the foundation of the structure shall comply with IBC Section 1810.3.11.2, and must not exceed the published capacities noted in Section 4.1.1 of this report.
 - b. The shaft seismic flexural length must be determined by a registered design professional in accordance with applicable code sections of the IBC. The shaft seismic flexural length is defined as the length of the shaft equal to 120 percent of the shaft flexural length.
 - c. The shaft couplers shall be limited to the shaft capacity reported in Section 4.1.3 of this report and must comply with the requirements in IBC Section 1810.3.6.1.
 - d. The analysis of the seismic forces imparted on the bracket, bracket connection to foundation or beam and pile must be prepared by a registered design professional taking into account soil characteristics such as liquefiable zone, length of pile in air or length of fluid conditions per the appropriate code.
- 5.4** All brackets must be used only to support structures that are laterally braced as defined in Section IBC Section 1810.2.2. Shaft couplings must be located within firm or soft soil as defined in Section 4.1.3.
- 5.5** Use of the helical foundation system in exposure conditions that are indicative of potential pile deterioration or corrosion situations as defined by the following: (1) soil resistivity less than 1,000 ohm-cm; (2) soil pH less than 5.5; (3) soils with high organic content; (4) soil sulfate concentrations greater than 1,000 ppm; (5) soils located in a landfill, or (6) soil containing mine waste is beyond the scope of the evaluation report.
- 5.6** Zinc-coated steel and plain steel components must not be combined in the same system, except that plain steel components can be used with zinc-coated steel components provided the properties of the plain steel are used in the design of the helical foundation system. All helical foundation components must be galvanically isolated from concrete reinforcing steel, building structural steel, or any other metal building components.
- 5.7** The helical piles must be installed vertically into the ground with a maximum allowable angle of inclination of ± 1 degree.
- 5.8** To comply with requirements found in IBC Section 1810.3.1.3, the superstructure must be designed to resist the effects of helical pile eccentricity.
- 5.9** Special inspection is provided in accordance with Section 4.3 of this report.
- 5.10** Engineering calculations and drawings, in accordance with recognized engineering principles as described in IBC Section 1604.4, and complying with Section 4.1 of this report, are prepared by a registered design professional and approved by the code official.
- 5.11** The adequacy of the supported structures that are connected to the brackets must be verified by a registered design professional in accordance with applicable code provisions, and subjected to the approval of the code official.
- 5.12** A geotechnical investigation report for each project site must be provided to the code official for approval in accordance with Section 4.1.1 of this report.
- 5.13** When using the alternative basic load combinations prescribed in 2021 IBC Section 1605.2 (2018, 2015, 2012 and 2009 IBC Section 1605.3.2), the allowable stress increases permitted by material chapters of the IBC (including Chapter 18) or the referenced standards are prohibited.

- 5.14** For lateral load, the minimum center-to-center spacing of helical piles in the direction of lateral force must be at least eight times the pile shaft outside diameter; and the spacing between helical plates must not be less than 3D, where D is the diameter of the largest helical plate measured from the edge of the helical plate to the edge of the adjacent helical pile plate, and 4D, where the spacing is measured from the center to the center of the adjacent helical pile plates. For axial load, the minimum center-to-center spacing of helical piles must not be less than three times the diameter of largest helix plate at the depth of bearing. For piles with closer spacing, the pile allowable load reductions due to pile group effects must be included in the geotechnical report described in Section 4.1.1 of this report, and must be considered in the pile design by a registered design professional. Load reductions are subject to the approval of the code official.
- 5.15** In tension applications, the helical pile must be installed such that the minimum depth from the ground surface to the helix is 12D, where D is the diameter of the helix.
- 5.16** Settlement of helical piles is beyond the scope of this evaluation report and must be determined by a registered design professional as required in IBC Section 1810.2.3 upon consultation with the report holder.
- 5.17** The applied loads must not exceed the allowable capacities described in Section 4.1 of this report.
- 5.18** Evaluation of compliance with Section IBC Sections 1810.3.11.1 and 1810.3.11.2 for buildings assigned to Seismic Design Category (SDC) C through F must be addressed by a registered design professional.
- 5.19** The Postech Screw pile foundation system is manufactured under a quality control program with inspections by ICC-ES.

6.0 EVIDENCE SUBMITTED

Data in accordance with the [ICC-ES Acceptance Criteria for Helical Pile Systems and Devices \(AC358\)](#), dated June 2020 (editorially revised March 2021).

7.0 IDENTIFICATION

- 7.1** Every helical pile, extension and bracket of the Postech Screw Pile foundation system described in this report is identified with a label indicating the manufacturer's name (Pieux Vistech/Postech Screw Piles, Inc.) and the ICC-ES evaluation report number (ESR-4735).
- 7.2** The report holder's contact information is the following:

PIEUX VISTECH/POSTECH SCREW PILES, INC.
10260 BOULEVARD BOURQUE
SHERBROOKE, QUEBEC J1N 0G2
CANADA
(819) 843-3003
www.pieuvistech.com
rba@pieuvistech.com

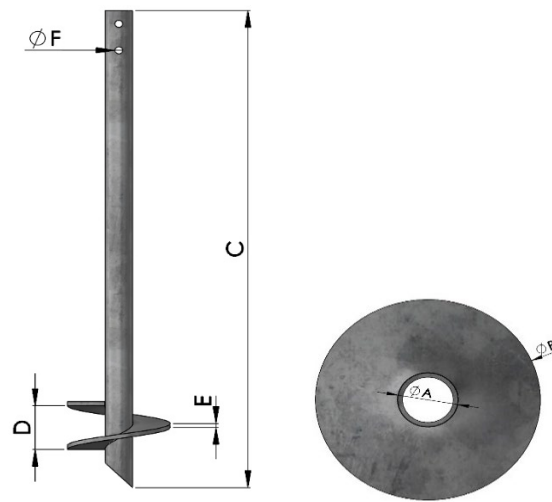

Products Name	A (in.)	B (in.)	C (in.)	D (in.)	E (in.)	F (in.)
P312L7-10	$\phi 3 \frac{1}{2}$ "	$\phi 10$ "	84"	3 1/2"	3/8"	$\phi 13/16$ "
P312L7-12	$\phi 3 \frac{1}{2}$ "	$\phi 12$ "	84"	3 1/2"	3/8"	$\phi 13/16$ "
P312L7-14	$\phi 3 \frac{1}{2}$ "	$\phi 14$ "	84"	4"	3/8"	$\phi 13/16$ "
P312L7-16	$\phi 3 \frac{1}{2}$ "	$\phi 16$ "	84"	4"	1/2"	$\phi 13/16$ "
P312L7-18	$\phi 3 \frac{1}{2}$ "	$\phi 18$ "	84"	4"	1/2"	$\phi 13/16$ "
P312L10-10	$\phi 3 \frac{1}{2}$ "	$\phi 10$ "	120"	3 1/2"	3/8"	$\phi 13/16$ "
P312L10-12	$\phi 3 \frac{1}{2}$ "	$\phi 12$ "	120"	3 1/2"	3/8"	$\phi 13/16$ "
P312L10-14	$\phi 3 \frac{1}{2}$ "	$\phi 14$ "	120"	4"	3/8"	$\phi 13/16$ "
P312L10-16	$\phi 3 \frac{1}{2}$ "	$\phi 16$ "	120"	4"	1/2"	$\phi 13/16$ "
P312L10-18	$\phi 3 \frac{1}{2}$ "	$\phi 18$ "	120"	4"	1/2"	$\phi 13/16$ "

For SI: 1 inch = 25.4 mm

FIGURE 1—HELICAL PILE LEAD SECTIONS (SINGLE HELIX)

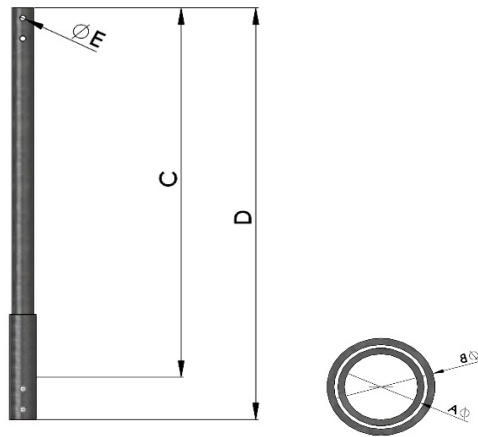

Products Name	A (in.)(1)	B (in.)(2)	C (in.)	D (in.)	E (in.)
EX312L3E	Ø3 1/2"	Ø4"	36"	41 1/8"	Ø13/16"
EX312L5E	Ø3 1/2"	Ø4"	60"	65 1/8"	Ø13/16"
EX312L7E	Ø3 1/2"	Ø4"	84"	89 1/8"	Ø13/16"
EX312L10E	Ø3 1/2"	Ø4"	120"	125 1/8"	Ø13/16"

For SI: 1 inch = 25.4 mm

FIGURE 2—EXTENSION SECTIONS

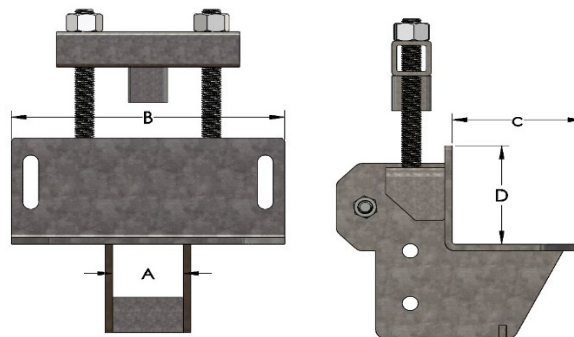

Products Name	A (in.)	B (in.)	C (in.)	D (in.)
TAL-U-312	3 5/8"	14"	6 5/8"	6 5/8"

For SI: 1 inch = 25.4 mm

FIGURE 3—UNDERPINNING (REPAIR) BRACKET

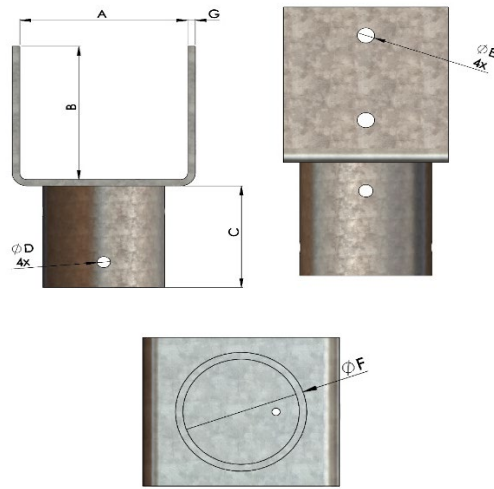

Product Name	A (in.)	B (in.)	C (in.)	D(in.)	E(in.)	F (in.)	G (in.)
TFU5-312E	4 5/8"	4 1/4"	4"	Ø1/2"	Ø17/32"	Ø4"	1/4"
TFU6-312E	5 1/2"	5 1/4"	4"	Ø1/2"	Ø17/32"	Ø4"	1/4"
TFU6+-312E	6 1/8"	5 7/16"	4"	Ø1/2"	Ø17/32"	Ø4"	1/4"
TFU8-312E	7 1/2"	8"	4"	Ø1/2"	Ø17/32"	Ø4"	1/4"
TFU8+-312E	8 1/8"	7 1/2"	4"	Ø1/2"	Ø17/32"	Ø4"	1/4"

For SI: 1 inch = 25.4 mm

FIGURE 4—"U" FIXED HEAD BRACKETS

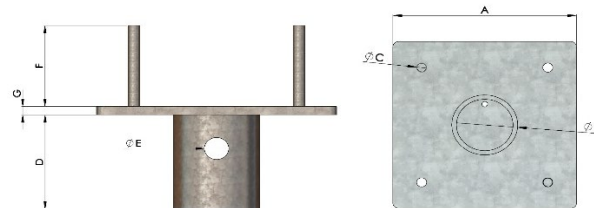

Products Name	A (in.)	B (in.)	C (in.)(1)	D (in.)	E (in.)	F (in.)	G (in.)
TFC6238E312i	6"	Ø2 7/8"	Ø7/16"	3 1/2"	Ø13/16"	3"	5/16"
TFC8238E312i	8"	Ø2 7/8"	Ø7/16"	3 1/2"	Ø13/16"	3"	5/16"

For SI: 1 inch = 25.4 mm

FIGURE 5—CONCRETE FIXED HEAD BRACKETS

TABLE 1—DESCRIPTION AND AXIAL SOIL CAPACITY OF PILE LEAD SECTIONS^{1,2}

Load Direction	Product No.	Length, (feet)	Helical Plate Diameter, (inch)	K _t , (ft ⁻¹)	Max. Installation Torque, (ft-lb)	Max. Ultimate Capacity, (lbf)	Max. Allowable Capacity, (lbf)
Compression	P312L7-10	7	10	7	8135	56,945	28,472
	P312L7-12	7	12	7	8135	56,945	28,472
	P312L7-14	7	14	7	8135	56,945	28,472
	P312L7-16	7	16	7	8135	56,945	28,472
	P312L7-18	7	18	7	8135	56,945	28,472
Tension	P312L7-10	7	10	7	8135	56,945	28,472
	P312L7-12	7	12	7	8135	56,945	28,472
	P312L7-14	7	14	7	8135	56,945	28,472
	P312L7-16	7	16	7	8135	56,945	28,472
	P312L7-18	7	18	7	8135	56,945	28,472

For SI: 1 inch = 25.4 mm, 1 foot = 304.8 mm, 1000 lbf = 4.448 N, 1lbf-ft = 1.356 N-m, 1 ft⁻¹ = 3.2808 m⁻¹.

¹Refer to Figure 1 for typical helical lead configuration.

²The ultimate and allowable soil capacities listed in this table are the smaller of the torque-correlation predicted maximum axial capacities and the axial verification test results.

TABLE 2—DESCRIPTION AND AXIAL SOIL CAPACITY OF PILE EXTENSIONS^{1,2}

Load Direction	Product No.	Length, (feet)	K _t , (ft ⁻¹)	Max. Installation Torque, (ft-lb)	Max. Ultimate Capacity, (lbf)	Max. Allowable Capacity, (lbf)
Compression	EX312L3E	3	7	8135	56,945	28,472
	EX312L5E	5	7	8135	56,945	28,472
	EX312L7E	7	7	8135	56,945	28,472
	EX312L10E	10	7	8135	56,945	28,472
Tension	EX312L3E	3	7	8135	56,945	28,472
	EX312L5E	5	7	8135	56,945	28,472
	EX312L7E	7	7	8135	56,945	28,472
	EX312L10E	10	7	8135	56,945	28,472

For SI: 1 foot = 305 mm, 1lbf = 4.448 N, 1lbf-ft = 1.356 N-m, 1 ft⁻¹ = 3.2808 m⁻¹.

¹Refer to Figure 1 for typical helical lead configuration.

²The ultimate and allowable soil capacities listed in this table are the smaller of the torque-correlation predicted maximum axial capacities and the axial verification test results.

TABLE 3—MECHANICAL PROPERTIES OF 3.5 INCH DIAMETER HELICAL SHAFT (HSS3.500X0.216)

Mechanical Properties	After Corrosion Loss (Plain Steel)	After Corrosion Loss (Galvanized Steel)
Steel Yield Strength, F_y	50 ksi	
Steel Ultimate Strength, F_u	65 ksi	
Modulus of Elasticity, E	29,000 ksi	
Nominal Wall Thickness	0.216 in	
Design Wall Thickness	0.165 in	0.194 in
Outside Diameter	3.464 in	3.493 in
Inside Diameter	3.134 in	3.105 in
Cross Sectional Area	1.71 in ²	2.01 in ²
Moment of Inertia, I	2.33 in ⁴	2.74 in ⁴
Radius of Gyration, r	1.17 in	1.17 in
Section Modulus, S	1.35 in ³	1.57 in ³
Plastic Section Modulus, Z	1.72 in ³	2.03 in ³

For SI: 1 in= 25.4 mm, 1 in²= 645 mm², 1 in³= 16387 mm³, 1 in⁴= 416231 mm⁴, 1 ksi= 6.9 MPa.

TABLE 4—ALLOWABLE AXIAL COMPRESSIVE STRENGTH OF UNDERPINNING (REPAIR) BRACKET^{1,2}

Concrete Foundation Compressive Strength ³ , psi	Allowable Axial Compressive Strength, kips
2500	19.15
3500	26.12

For SI: 1 psi= 6.9 kPa, 1 kip= 4.45 kN.

¹ Load capacity is based on full scale load tests per AC358 with an installed 5 foot unbraced pile length having a maximum of one coupling per IBC Section 1810.2.1. Load capacity assumes the structure is sidesway braced per IBC Section 1810.2.5. Side load bracket must be concentrically loaded. Side load bracket plate must be fully engaged with bottom of concrete foundation. Only localized limit states such as mechanical strength of steel components and concrete bearing have been evaluated. The repair bracket was attached to the face of the foundation using two (2) anchor bolts described in Section 3.3.4.1 of this report.

² When tension or lateral load capacities are required for the repair brackets, the capacities must be determined by a registered design professional in accordance with IBC Chapter 18.

³ Concrete strength is the specified compressive strength at 28 days.

TABLE 5A—U SHAPE FIXED HEAD STEEL BRACKET MECHANICAL ALLOWABLE CAPACITIES^{1,2}

U-Shape Fixed Head Bracket	Allowable Compression, kips		Allowable Tension, kips		Allowable Shear, kips	
	plain steel	galvanized steel	plain steel	galvanized steel	plain steel	galvanized steel
5 inch	51.20	60.20	6.16	7.03	18.40	21.58
6 inch	51.20	60.20	3.74	5.00	18.40	21.58
6 inch plus	51.20	60.20	2.78	3.69	18.40	21.58
8 inch	51.20	60.20	2.25	2.95	18.40	21.58
8 inch plus	51.20	60.20	1.99	2.61	18.40	21.58

For SI: 1 kip= 4.48 kN.

¹ Capacities include allowance for corrosion over a 50-year service life in accordance with Section 3.9 of AC358 and presume the supported structure is braced in accordance with IBC Section 1810.2.2. Load capacity assumes the bracket is concentrically loaded. Only localized limit states such as mechanical strength of steel components have been evaluated. For connection of bracket to wood members, the tabulated capacities reported in Tables 5B through 5D may be considered.

² Load capacity assumes bracket is connected to helical shaft using one ½-inch-diameter bolts as described in Section 3.3.5 per side for a total of two bolts.

TABLE 5B—U SHAPE FIXED HEAD STEEL BRACKET CONNECTED TO WOOD BEAM (FORCE PERPENDICULAR TO GRAIN)^(1,2)

F_{cL} ³ , psi	U-Shape Fixed Head Plain Steel Bracket Allowable Compressive Capacity ^{4,5} , kips									
	5-inch		6-inch		6-inch Plus		8-inch		8-inch Plus	
	Wet Service	Dry Service	Wet Service	Dry Service	Wet Service	Dry Service	Wet Service	Dry Service	Wet Service	Dry Service
200	3.22	4.81	3.85	5.74	4.29	6.41	7.25	10.83	8.94	13.34
250	4.02	6.01	4.81	7.17	5.37	8.01	9.07	13.53	11.17	16.68
300	4.83	7.21	5.77	8.61	6.44	9.61	10.88	16.24	13.41	20.01
350	5.63	8.41	6.73	10.04	7.51	11.21	12.69	18.94	15.64	23.35
400	6.44	9.61	7.69	11.48	8.59	12.81	14.51	21.65	17.88	26.68
450	7.24	10.81	8.65	12.91	9.66	14.42	16.32	24.36	20.11	30.02
500	8.05	12.01	9.61	14.35	10.73	16.02	18.13	27.06	22.35	33.36
550	8.85	13.21	10.57	15.78	11.80	17.62	19.95	29.77	24.58	36.69
600	9.66	14.42	11.54	17.22	12.88	19.22	21.76	32.48	26.82	40.03
650	10.46	15.62	12.50	18.65	13.95	20.82	23.57	35.18	29.05	43.36
700	11.27	16.82	13.46	20.09	15.02	22.42	25.38	37.89	31.29	46.70
750	12.07	18.02	14.42	21.52	16.10	24.03	27.20	40.59	33.52	50.03
800	12.88	19.22	15.38	22.96	17.17	25.63	29.01	43.30	35.76	53.37
850	13.68	20.42	16.34	24.39	18.24	27.23	30.82	46.01	37.99	56.71
900	14.49	21.62	17.30	25.83	19.32	28.83	32.64	48.71	40.23	60.04
F_{cL} ³ , psi	U-Shape Fixed Head Galvanized Steel Bracket Allowable Compressive Capacity ^{4,5} , kips									
	5-inch		6-inch		6-inch Plus		8-inch		8-inch Plus	
	Wet Service	Dry Service	Wet Service	Dry Service	Wet Service	Dry Service	Wet Service	Dry Service	Wet Service	Dry Service
200	3.24	4.83	3.87	5.77	4.32	6.44	7.28	10.87	8.97	13.39
250	4.05	6.04	4.83	7.21	5.39	8.05	9.10	13.58	11.21	16.74
300	4.86	7.25	5.80	8.66	6.47	9.66	10.92	16.30	13.46	20.08
350	5.66	8.45	6.77	10.10	7.55	11.27	12.74	19.02	15.70	23.43
400	6.47	9.66	7.73	11.54	8.63	12.88	14.56	21.74	17.94	26.78
450	7.28	10.87	8.70	12.98	9.71	14.49	16.38	24.45	20.18	30.12
500	8.09	12.08	9.67	14.43	10.79	16.10	18.20	27.17	22.43	33.47
550	8.90	13.29	10.63	15.87	11.87	17.71	20.02	29.89	24.67	36.82
600	9.71	14.49	11.60	17.31	12.95	19.32	21.84	32.60	26.91	40.17
650	10.52	15.70	12.57	18.75	14.03	20.94	23.66	35.32	29.15	43.51
700	11.33	16.91	13.53	20.20	15.11	22.55	25.48	38.04	31.40	46.86
750	12.14	18.12	14.50	21.64	16.18	24.16	27.31	40.75	33.64	50.21
800	12.95	19.32	15.47	23.08	17.26	25.77	29.13	43.47	35.88	53.56
850	13.76	20.53	16.43	24.53	18.34	27.38	30.95	46.19	38.12	56.90
900	14.57	21.74	17.40	25.97	19.42	28.99	32.77	48.91	40.37	60.25

For SI: 1 kip = 4.448 kN, 1 psi = 6.895 kPa.

¹Linear interpolation between wood compression perpendicular to grain values is permitted for the same bracket.

²Capacities include allowance for corrosion over a 50-year service life in accordance with Section 3.9 of AC308. ³Reference design value of wood is compression perpendicular to grain.

⁴The allowable compressive capacities are based on the following end-use conditions and limitations:

- Actual lumber widths are the following: 4.5 inches for 5-inch bracket; 5.375 inches for the 6-inch bracket; 6 inches for the 6-inch plus bracket; 7.375 inches for the 8-inch bracket; 8 inches for the 8-inch plus bracket.
- The wood beam is located at center of the bracket with respect to the bracket width dimension.
- A wet service factor of 0.67 is assumed.
- Wood will not experience sustained exposure to elevated temperatures such that the temperature factor is 1.0.
- Lumber is not incised such that the incising factor for the lumber is 1.0.
- A load duration factor of 1.0 is assumed for calculating the connection capacity.
- The bearing length measured parallel to grain is 5 inches, when calculating the bearing area factor prescribed in NDS equation (3.10-2).
- Fasteners in contact with preservative-treated wood must be hot-dipped zinc-coated galvanized steel in accordance with IBC Section 2304.10.6.

⁵If any one of the conditions described in footnote 4, above, is not satisfied, the connection capacity must be revised based on calculations provided by a registered design professional, and the revised capacities must be subjected to the approval of the code official.

TABLE 5C—U SHAPE FIXED HEAD STEEL BRACKET CONNECTED TO WOOD COLUMN OR POST (FORCE PARALLEL TO GRAIN)^{1,2}

F_{cl} ³ , psi	U-Shape Fixed Head Plain Steel Bracket Allowable Compressive Capacity ^{4,5} , kips									
	5-inch		6-inch		6-inch Plus		8-inch		8-inch Plus	
	Wet Service	Dry Service	Wet Service	Dry Service	Wet Service	Dry Service	Wet Service	Dry Service	Wet Service	Dry Service
300	6.70	6.70	8.00	8.00	8.94	8.94	15.41	15.41	19.11	19.11
350	7.82	7.82	9.34	9.34	10.42	10.42	17.98	17.98	22.30	22.30
400	8.94	8.94	10.67	10.67	11.91	11.91	20.54	20.54	25.48	25.48
450	10.05	10.05	12.01	12.01	13.40	13.40	23.11	23.11	28.67	28.67
500	11.17	11.17	13.34	13.34	14.89	14.89	25.68	25.68	31.86	31.86
550	12.29	12.29	14.67	14.67	16.38	16.38	28.25	28.25	35.04	35.04
600	13.40	13.40	16.01	16.01	17.87	17.87	30.82	30.82	38.23	38.23
650	14.52	14.52	17.34	17.34	19.36	19.36	33.38	33.38	41.41	41.41
700	15.64	15.64	18.68	18.68	20.85	20.85	35.95	35.95	44.60	44.60
750	16.75	16.75	20.01	20.01	22.34	22.34	38.52	38.52	47.78	47.78
800	14.30	17.87	17.08	21.35	19.06	23.83	32.87	41.09	40.78	50.97
900	16.08	20.10	19.21	24.01	21.44	26.81	36.98	46.22	45.87	51.20
1000	17.87	22.34	21.35	26.68	23.83	29.78	41.09	51.20	50.97	51.20
1100	19.66	24.57	23.48	29.35	26.21	32.76	45.20	51.20	51.20	51.20
1200	21.44	26.81	25.61	32.02	28.59	35.74	49.31	51.20	51.20	51.20
1300	23.23	29.04	27.75	34.69	30.98	38.72	51.20	51.20	51.20	51.20
1400	25.02	31.27	29.88	37.35	33.36	41.70	51.20	51.20	51.20	51.20
1500	26.81	33.51	32.02	40.02	35.74	44.68	51.20	51.20	51.20	51.20
1600	28.59	35.74	34.15	42.69	38.12	47.65	51.20	51.20	51.20	51.20
1700	30.38	37.97	36.29	45.36	40.51	50.63	51.20	51.20	51.20	51.20
1800	32.17	40.21	38.42	48.03	42.89	51.20	51.20	51.20	51.20	51.20
1900	33.95	42.44	40.56	50.69	45.27	51.20	51.20	51.20	51.20	51.20
2000	35.74	44.68	42.69	51.20	47.65	51.20	51.20	51.20	51.20	51.20
2100	37.53	46.91	44.82	51.20	50.04	51.20	51.20	51.20	51.20	51.20
U-Shape Fixed Head Galvanized Steel Bracket Allowable Compressive Capacity ^{4,5} , kips										
300	6.74	6.74	8.05	8.05	8.99	8.99	15.47	15.47	19.18	19.18
350	7.86	7.86	9.39	9.39	10.49	10.49	18.05	18.05	22.38	22.38
400	8.99	8.99	10.73	10.73	11.98	11.98	20.63	20.63	25.58	25.58
450	10.11	10.11	12.08	12.08	13.48	13.48	23.21	23.21	28.77	28.77
500	11.23	11.23	13.42	13.42	14.98	14.98	25.79	25.79	31.97	31.97
550	12.36	12.36	14.76	14.76	16.48	16.48	28.37	28.37	35.17	35.17
600	13.48	13.48	16.10	16.10	17.97	17.97	30.94	30.94	38.37	38.37
650	14.60	14.60	17.44	17.44	19.47	19.47	33.52	33.52	41.56	41.56
700	15.73	15.73	18.79	18.79	20.97	20.97	36.10	36.10	44.76	44.76
750	16.85	16.85	20.13	20.13	22.47	22.47	38.68	38.68	47.96	47.96
800	14.38	17.97	17.18	21.47	19.17	23.97	33.01	41.26	40.92	51.16
900	16.18	20.22	19.32	24.15	21.57	26.96	37.13	46.42	46.04	57.55
1000	17.97	22.47	21.47	26.84	23.97	29.96	41.26	51.57	51.16	60.20
1100	19.77	24.72	23.62	29.52	26.36	32.95	45.38	56.73	56.27	60.20
1200	21.57	26.96	25.76	32.20	28.76	35.95	49.51	60.20	60.20	60.20
1300	23.37	29.21	27.91	34.89	31.16	38.95	53.64	60.20	60.20	60.20
1400	25.16	31.46	30.06	37.57	33.55	41.94	57.76	60.20	60.20	60.20
1500	26.96	33.70	32.20	40.26	35.95	44.94	60.20	60.20	60.20	60.20
1600	28.76	35.95	34.35	42.94	38.35	47.93	60.20	60.20	60.20	60.20
1700	30.56	38.20	36.50	45.62	40.74	50.93	60.20	60.20	60.20	60.20
1800	32.35	40.44	38.65	48.31	43.14	53.92	60.20	60.20	60.20	60.20
1900	34.15	42.69	40.79	50.99	45.54	56.92	60.20	60.20	60.20	60.20
2000	35.95	44.94	42.94	53.67	47.93	59.92	60.20	60.20	60.20	60.20
2100	37.75	47.18	45.09	56.36	50.33	60.20	60.20	60.20	60.20	60.20

For SI: 1 kip = 4.448 kN, 1 psi = 6.895 kPa.

¹Linear interpolation between wood compression parallel to grain values is permitted for the same bracket.

²Capacities include allowance for corrosion over a 50-year service life in accordance with Section 3.9 of AC308. ³Reference design value of wood is compression parallel to grain.

⁴The allowable compressive capacities are based on the following end-use conditions and limitations:

- Actual lumber widths are the following: 4.5 inches for 5-inch bracket; 5.375 inches for the 6-inch bracket; 6 inches for the 6-inch plus bracket; 7.375 inches for the 8-inch bracket; 8 inches for the 8-inch plus bracket.
- The wood column is located at center of the bracket with respect to the bracket width dimension.
- A wet service factor of 1.0 is assumed, except a wet service factor of 0.8 is assumed where $F_{cl} \leq 750 \text{ psi}$.
- Wood will not experience sustained exposure to elevated temperatures such that the temperature factor is 1.0.
- Lumber is not incised such that the incising factor for the lumber is 1.0.
- A load duration factor of 1.0 is assumed for calculating the connection capacity.
- A size factor, C_F , of 1.0 is assumed.
- A column stability factor, C_p , of 1.0 is assumed.
- Fasteners in contact with preservative-treated wood must be hot-dipped zinc-coated galvanized steel in accordance with IBC Section 2304.10.6.

⁵If any one of the conditions described in footnote 4, above, is not satisfied, the connection capacity must be revised based on calculations provided by a registered design professional, and the revised capacities must be subjected to the approval of the code official.

TABLE 5D—U SHAPE FIXED HEAD STEEL BRACKET CONNECTED TO WOOD BEAM (FORCE PERPENDICULAR TO GRAIN)^{1,2}

G ³	U-Shape Fixed Head Plain Steel Bracket Allowable Tension Capacity ^{4,5} , lbf									
	5-inch		6-inch		6-inch Plus		8-inch		8-inch Plus	
	Wet Service	Dry Service	Wet Service	Dry Service	Wet Service	Dry Service	Wet Service	Dry Service	Wet Service	Dry Service
0.31	1613	2304	1737	2482	1737	2482	1737	2254	1789	1993
0.32	1663	2376	1762	2517	1762	2517	1762	2254	1814	1993
0.33	1764	2520	1809	2584	1809	2584	1809	2254	1864	1993
0.34	1814	2592	1832	2617	1832	2617	1832	2254	1889	1993
0.35	1876	2681	1876	2681	1876	2681	1876	2254	1937	1993
0.36	1898	2712	1898	2712	1898	2712	1898	2254	1960	1993
0.37	1941	2773	1941	2773	1941	2773	1941	2254	1993	1993
0.38	1962	2802	1962	2802	1962	2781	1962	2254	1993	1993
0.39	2002	2861	2002	2861	2002	2781	2002	2254	1993	1993
0.40	2042	2917	2042	2917	2042	2781	2042	2254	1993	1993
0.41	2061	2945	2061	2945	2061	2781	2061	2254	1993	1993
0.42	2099	2999	2099	2999	2099	2781	2099	2254	1993	1993
0.43	2136	3052	2136	3052	2136	2781	2136	2254	1993	1993
0.44	2155	3078	2155	3078	2155	2781	2155	2254	1993	1993
0.45	2190	3129	2190	3129	2190	2781	2190	2254	1993	1993
0.46	2225	3179	2225	3179	2225	2781	2225	2254	1993	1993
0.47	2259	3227	2259	3227	2259	2781	2254	2254	1993	1993
0.48	2292	3275	2292	3275	2292	2781	2254	2254	1993	1993
0.49	2309	3298	2309	3298	2309	2781	2254	2254	1993	1993
0.50	2341	3344	2341	3344	2341	2781	2254	2254	1993	1993
0.51	2373	3389	2373	3389	2373	2781	2254	2254	1993	1993
0.52	2404	3434	2404	3434	2404	2781	2254	2254	1993	1993
0.53	2434	3477	2434	3477	2434	2781	2254	2254	1993	1993
0.54	2464	3519	2464	3519	2464	2781	2254	2254	1993	1993
0.55	2493	3561	2493	3561	2493	2781	2254	2254	1993	1993
0.56	2507	3582	2507	3582	2507	2781	2254	2254	1993	1993
0.57	2536	3622	2536	3622	2536	2781	2254	2254	1993	1993
0.58	2564	3662	2564	3701	2564	2781	2254	2254	1993	1993
0.59	2591	3701	2591	3736	2591	2781	2254	2254	1993	1993
0.60	2618	3740	2618	3736	2618	2781	2254	2254	1993	1993
0.61	2645	3778	2645	3736	2645	2781	2254	2254	1993	1993
0.62	2671	3815	2671	3736	2671	2781	2254	2254	1993	1993
0.63	2696	3852	2696	3736	2696	2781	2254	2254	1993	1993
0.64	2722	3888	2722	3736	2722	2781	2254	2254	1993	1993
0.65	2747	3924	2747	3736	2747	2781	2254	2254	1993	1993
0.66	2771	3959	2771	3736	2771	2781	2254	2254	1993	1993
0.67	2807	4010	2807	3736	2781	2781	2254	2254	1993	1993
0.68	2831	4044	2831	3736	2781	2781	2254	2254	1993	1993
0.69	2854	4077	2854	3736	2781	2781	2254	2254	1993	1993
0.70	2877	4110	2877	3736	2781	2781	2254	2254	1993	1993
0.71	2900	4143	2900	3736	2781	2781	2254	2254	1993	1993
0.72	2922	4175	2922	3736	2781	2781	2254	2254	1993	1993
0.73	2944	4206	2944	3736	2781	2781	2254	2254	1993	1993

TABLE 5D—U SHAPE FIXED HEAD STEEL BRACKET CONNECTED TO WOOD BEAM (FORCE PERPENDICULAR TO GRAIN)^{1,2}
(CONTINUED)

G ³	5-inch		6-inch		6-inch Plus		8-inch		8-inch Plus	
	Wet Services	Dry Service	Wet Service	Dry Service	Wet Service	Dry Service	Wet Service	Dry Service	Wet Service	Dry Service
U-Shape Fixed Head Galvanized Steel Bracket Allowable Tension Capacity^{4,5}, lbf										
0.31	1613	2304	1869	2671	1869	2671	1869	2671	1924	2605
0.32	1663	2376	1897	2710	1897	2710	1897	2710	1953	2605
0.33	1764	2520	1951	2788	1951	2788	1951	2788	2011	2605
0.34	1814	2592	1978	2825	1978	2825	1978	2825	2039	2605
0.35	1915	2736	2029	2899	2029	2899	2029	2899	2093	2605
0.36	1966	2808	2055	2935	2055	2935	2055	2935	2118	2605
0.37	2066	2952	2103	3004	2103	3004	2103	2951	2168	2605
0.38	2117	3024	2125	3036	2125	3036	2125	2951	2193	2605
0.39	2170	3100	2170	3100	2170	3100	2170	2951	2241	2605
0.40	2214	3163	2214	3163	2214	3163	2214	2951	2287	2605
0.41	2235	3193	2235	3193	2235	3193	2235	2951	2310	2605
0.42	2277	3253	2277	3253	2277	3253	2277	2951	2355	2605
0.43	2318	3312	2318	3312	2318	3312	2318	2951	2399	2605
0.44	2338	3340	2338	3340	2338	3340	2338	2951	2420	2605
0.45	2378	3397	2378	3397	2378	3397	2378	2951	2463	2605
0.46	2416	3452	2416	3452	2416	3452	2416	2951	2504	2605
0.47	2454	3505	2454	3505	2454	3505	2454	2951	2545	2605
0.48	2491	3558	2491	3558	2491	3558	2491	2951	2585	2605
0.49	2509	3584	2509	3584	2509	3584	2509	2951	2604	2605
0.50	2544	3635	2544	3635	2544	3635	2544	2951	2605	2605
0.51	2579	3685	2579	3685	2579	3685	2579	2951	2605	2605
0.52	2614	3734	2614	3734	2614	3695	2614	2951	2605	2605
0.53	2647	3782	2647	3782	2647	3695	2647	2951	2605	2605
0.54	2680	3829	2680	3829	2680	3695	2680	2951	2605	2605
0.55	2713	3876	2713	3876	2713	3695	2713	2951	2605	2605
0.56	2729	3898	2729	3898	2729	3695	2729	2951	2605	2605
U-Shape Fixed Head Plain Steel Bracket Allowable Tension Capacity^{4,5}, lbf										
0.57	2761	3944	2761	3944	2761	3695	2761	2951	2605	2605
0.58	2792	3988	2792	3988	2792	3695	2792	2951	2605	2605
0.59	2822	4032	2822	4032	2822	3695	2822	2951	2605	2605
0.60	2852	4075	2852	4075	2852	3695	2852	2951	2605	2605
0.61	2882	4117	2882	4117	2882	3695	2882	2951	2605	2605
0.62	2911	4158	2911	4158	2911	3695	2911	2951	2605	2605
0.63	2940	4199	2940	4199	2940	3695	2940	2951	2605	2605
0.64	2968	4240	2968	4240	2968	3695	2951	2951	2605	2605
0.65	2996	4279	2996	4279	2996	3695	2951	2951	2605	2605
0.66	3023	4319	3023	4319	3023	3695	2951	2951	2605	2605
0.67	3063	4376	3063	4376	3063	3695	2951	2951	2605	2605
0.68	3090	4414	3090	4414	3090	3695	2951	2951	2605	2605
0.69	3116	4451	3116	4451	3116	3695	2951	2951	2605	2605
0.70	3142	4488	3142	4488	3142	3695	2951	2951	2605	2605
0.71	3167	4525	3167	4525	3167	3695	2951	2951	2605	2605
0.72	3192	4560	3192	4560	3192	3695	2951	2951	2605	2605
0.73	3217	4596	3217	4596	3217	3695	2951	2951	2605	2605

For SI: 1 kip = 4.448 kN, 1 psi = 6.895 kPa.

¹Linear interpolation between force applied perpendicular to grain values is permitted for the same bracket.

²Capacities include allowance for corrosion over a 50-year service life in accordance with Section 3.9 of AC308.

³G is the specific gravity of sawn lumber or equivalent specific gravity of engineered wood beams.

⁴The allowable tension capacities are based on the following end-use conditions and limitations:

- Actual lumber widths are the following: 4.5 inches for 5-inch bracket; 5.375 inches for the 6-inch bracket; 6 inches for the 6-inch plus bracket; 7.375 inches for the 8-inch bracket; 8 inches for the 8-inch plus bracket.
- The wood beam is located at center of the bracket with respect to the bracket width dimension.
- For wet service conditions, a wet service factor of 0.7 is assumed. Otherwise a wet service factor of 1.0 is assumed.
- Wood will not experience sustained exposure to elevated temperatures such that the temperature factor is 1.0.
- Lumber is not incised such that the incising factor for the lumber is 1.0.
- A load duration factor of 1.6 is assumed for calculating the connection capacity.
- Two (2)- 1/2-inch-diameter through bolts complying with ASTM A307 must be used to connect wood beam to bracket.
- Fasteners in contact with preservative-treated wood must be hot-dipped zinc-coated galvanized steel in accordance with IBC Section 2304.10.6.
- Mechanical reinforcement sufficient to resist tension stresses perpendicular to grain must be considered.

⁵If any one of the conditions described in footnote 4, above, is not satisfied, the connection capacity must be revised based on calculations provided by a registered design professional, and the revised capacities must be subjected to the approval of the code official.

TABLE 5E—U SHAPE FIXED HEAD STEEL BRACKET CONNECTED TO WOOD POST OR COLUMN (FORCE PARALLEL TO GRAIN)^{1,2}

G ³	U-Shape Fixed Head Plain Steel Bracket Allowable Tension Capacity ^{4,5} , lbf									
	5-inch		6-inch		6-inch Plus		8-inch		8-inch Plus	
	Wet Service	Dry Service	Wet Service	Dry Service	Wet Service	Dry Service	Wet Service	Dry Service	Wet Service	Dry Service
0.31	2016	2880	2172	3103	2172	2781	2172	2254	1993	1993
0.32	2079	2970	2202	3146	2202	2781	2202	2254	1993	1993
0.33	2205	3150	2261	3230	2261	2781	2254	2254	1993	1993
0.34	2268	3240	2290	3271	2290	2781	2254	2254	1993	1993
0.35	2345	3351	2345	3351	2345	2781	2254	2254	1993	1993
0.36	2373	3390	2373	3390	2373	2781	2254	2254	1993	1993
0.37	2426	3466	2426	3466	2426	2781	2254	2254	1993	1993
0.38	2452	3503	2452	3503	2452	2781	2254	2254	1993	1993
0.39	2503	3576	2503	3576	2503	2781	2254	2254	1993	1993
0.40	2552	3646	2552	3646	2552	2781	2254	2254	1993	1993
0.41	2577	3681	2577	3681	2577	2781	2254	2254	1993	1993
0.42	2624	3749	2624	3736	2624	2781	2254	2254	1993	1993
0.43	2670	3815	2670	3736	2670	2781	2254	2254	1993	1993
0.44	2693	3847	2693	3736	2693	2781	2254	2254	1993	1993
0.45	2738	3911	2738	3736	2738	2781	2254	2254	1993	1993
0.46	2781	3973	2781	3736	2781	2781	2254	2254	1993	1993
0.47	2824	4034	2824	3736	2781	2781	2254	2254	1993	1993
0.48	2866	4094	2866	3736	2781	2781	2254	2254	1993	1993
0.49	2886	4123	2886	3736	2781	2781	2254	2254	1993	1993
0.50	2926	4180	2926	3736	2781	2781	2254	2254	1993	1993
0.51	2966	4237	2966	3736	2781	2781	2254	2254	1993	1993
0.52	3004	4292	3004	3736	2781	2781	2254	2254	1993	1993
0.53	3042	4346	3042	3736	2781	2781	2254	2254	1993	1993
0.54	3080	4399	3080	3736	2781	2781	2254	2254	1993	1993
0.55	3116	4452	3116	3736	2781	2781	2254	2254	1993	1993
0.56	3134	4477	3134	3736	2781	2781	2254	2254	1993	1993
	U-Shape Fixed Head Plain Steel Bracket Allowable Tension Capacity^{4,5}, lbf									
0.57	3170	4528	3170	3736	2781	2781	2254	2254	1993	1993
0.58	3204	4578	3204	3736	2781	2781	2254	2254	1993	1993
0.59	3239	4627	3239	3736	2781	2781	2254	2254	1993	1993
0.60	3272	4675	3272	3736	2781	2781	2254	2254	1993	1993
0.61	3306	4722	3306	3736	2781	2781	2254	2254	1993	1993
0.62	3338	4769	3338	3736	2781	2781	2254	2254	1993	1993
0.63	3370	4815	3370	3736	2781	2781	2254	2254	1993	1993
0.64	3402	4860	3402	3736	2781	2781	2254	2254	1993	1993
0.65	3433	4905	3433	3736	2781	2781	2254	2254	1993	1993
0.66	3464	4948	3464	3736	2781	2781	2254	2254	1993	1993
0.67	3509	5013	3509	3736	2781	2781	2254	2254	1993	1993
0.68	3539	5055	3539	3736	2781	2781	2254	2254	1993	1993
0.69	3568	5097	3568	3736	2781	2781	2254	2254	1993	1993
0.70	3597	5138	3597	3736	2781	2781	2254	2254	1993	1993
0.71	3625	5178	3625	3736	2781	2781	2254	2254	1993	1993
0.72	3653	5218	3653	3736	2781	2781	2254	2254	1993	1993
0.73	3681	5258	3681	3736	2781	2781	2254	2254	1993	1993

**TABLE 5E—U SHAPE FIXED HEAD STEEL BRACKET CONNECTED TO WOOD POST OR COLUMN (FORCE PARALLEL TO GRAIN)^{1,2}
(CONTINUED)**

G ³	5-inch		6-inch		6-inch Plus		8 -inch		8-inch Plus	
	Wet Service	Dry Service	Wet service	Dry Service	Wet Service	Dry Service	Wet Service	Dry Service	Wet Service	Dry Service
U-Shape Fixed Head Galvanized Steel Bracket Allowable Tension Capacity^{4,5}, lbf										
0.31	2016	2880	2337	3338	2337	3338	2337	2951	2405	2605
0.32	2079	2970	2371	3388	2371	3388	2371	2951	2442	2605
0.33	2205	3150	2439	3484	2439	3484	2439	2951	2513	2605
0.34	2268	3240	2472	3532	2472	3532	2472	2951	2549	2605
0.35	2394	3420	2537	3624	2537	3624	2537	2951	2605	2605
0.36	2457	3510	2568	3669	2568	3669	2568	2951	2605	2605
0.37	2583	3690	2628	3755	2628	3695	2628	2951	2605	2605
0.38	2646	3780	2657	3795	2657	3695	2657	2951	2605	2605
0.39	2713	3876	2713	3876	2713	3695	2713	2951	2605	2605
0.40	2767	3953	2767	3953	2767	3695	2767	2951	2605	2605
0.41	2794	3992	2794	3992	2794	3695	2794	2951	2605	2605
0.42	2847	4066	2847	4066	2847	3695	2847	2951	2605	2605
0.43	2898	4139	2898	4139	2898	3695	2898	2951	2605	2605
0.44	2923	4175	2923	4175	2923	3695	2923	2951	2605	2605
0.45	2972	4246	2972	4246	2972	3695	2951	2951	2605	2605
0.46	3020	4314	3020	4314	3020	3695	2951	2951	2605	2605
0.47	3067	4382	3067	4382	3067	3695	2951	2951	2605	2605
0.48	3113	4448	3113	4448	3113	3695	2951	2951	2605	2605
0.49	3136	4480	3136	4480	3136	3695	2951	2951	2605	2605
0.50	3181	4544	3181	4544	3181	3695	2951	2951	2605	2605
0.51	3224	4606	3224	4606	3224	3695	2951	2951	2605	2605
0.52	3267	4667	3267	4667	3267	3695	2951	2951	2605	2605
0.53	3309	4728	3309	4728	3309	3695	2951	2951	2605	2605
0.54	3351	4787	3351	4787	3351	3695	2951	2951	2605	2605
0.55	3391	4845	3391	4845	3391	3695	2951	2951	2605	2605
0.56	3411	4873	3411	4873	3411	3695	2951	2951	2605	2605
0.57	3451	4930	3451	4930	3451	3695	2951	2951	2605	2605
0.58	3490	4985	3490	4985	3490	3695	2951	2951	2605	2605
0.59	3528	5040	3528	5004	3528	3695	2951	2951	2605	2605
0.60	3565	5093	3565	5004	3565	3695	2951	2951	2605	2605
0.61	3602	5146	3602	5004	3602	3695	2951	2951	2605	2605
0.62	3639	5198	3639	5004	3639	3695	2951	2951	2605	2605
0.63	3674	5249	3674	5004	3674	3695	2951	2951	2605	2605
0.64	3710	5300	3710	5004	3695	3695	2951	2951	2605	2605
0.65	3745	5349	3745	5004	3695	3695	2951	2951	2605	2605
0.66	3779	5398	3779	5004	3695	3695	2951	2951	2605	2605
0.67	3829	5470	3829	5004	3695	3695	2951	2951	2605	2605
0.68	3862	5518	3862	5004	3695	3695	2951	2951	2605	2605
0.69	3895	5564	3895	5004	3695	3695	2951	2951	2605	2605
0.70	3927	5610	3927	5004	3695	3695	2951	2951	2605	2605
0.71	3959	5656	3959	5004	3695	3695	2951	2951	2605	2605
0.72	3990	5701	3990	5004	3695	3695	2951	2951	2605	2605
0.73	4021	5745	4021	5004	3695	3695	2951	2951	2605	2605

For SI: 1 lbf = 4.448 N, 1 inch = 25.4 mm.

¹Linear interpolation between force applied parallel to grain values is permitted for the same bracket.

²Capacities include allowance for corrosion over a 50-year service life in accordance with Section 3.9 of AC308.

³G is the specific gravity of sawn lumber or equivalent specific gravity of engineered wood beams.

⁴The allowable tension capacities are based on the following end-use conditions and limitations:

- Actual lumber widths are the following: 4.5 inches for 5-inch bracket; 5.375 inches for the 6-inch bracket; 6 inches for the 6-inch plus bracket; 7.375 inches for the 8-inch bracket; 8 inches for the 8-inch plus bracket.
- The wood column or post is located at center of the bracket with respect to the bracket width dimension.
- For wet service conditions, a wet service factor of 0.7 is assumed. Otherwise a wet service factor of 1.0 is assumed.
- Wood will not experience sustained exposure to elevated temperatures such that the temperature factor is 1.0.
- Lumber is not incised such that the incising factor for the lumber is 1.0.
- A load duration factor of 1.6 is assumed for calculating the connection capacity.
- Two (2)- 1/2-inch-diameter through bolts complying with ASTM A307 must be used to connect wood beam to bracket.
- Fasteners in contact with preservative-treated wood must be hot-dipped zinc-coated galvanized steel in accordance with IBC Section 2304.10.6.

⁵If any one of the conditions described in footnote 4, above, is not satisfied, the connection capacity must be revised based on calculations provided by a registered design professional, and the revised capacities must be subjected to the approval of the code official.

TABLE 6A—CONCRETE FIXED HEAD BRACKET ALLOWABLE CAPACITIES SEISMIC DESIGN CATEGORIES A AND B¹

Concrete Fixed Head Bracket	Steel Finish	Concrete Compressive Strength ⁴ , psi	Axial Compression		Axial Tension		Lateral Load	
			Min. Concrete Cover ²	Full Concrete Cover ³	Min. Concrete Cover ²	Full Concrete Cover ³	Min Concrete Cover ²	Full Concrete Cover ³
			(kips)	(kips)	(kips)	(kips)	(kips)	(kips)
6 inch	Plain	3500	10.54	23.55	1.84	9.82	1.5	4.17
		4000	11.26	26.92	1.97	9.82	1.6	4.46
	Galvanized	3500	10.57	23.95	1.85	11.64	1.5	5.31
		4000	11.30	27.37	1.98	11.64	1.6	5.67
8 inch	Plain	3500	8.96	23.55	2.37	8.96	1.8	4.75
		4000	8.96	26.92	2.53	8.96	1.9	3.86
	Galvanized	3500	10.99	23.95	2.38	10.99	1.8	4.75
		4000	10.99	27.37	2.54	10.99	1.9	5.07

For SI: 1 inch = 25.4 mm, 1 kip = 4.448 kN, 1 psi=.

¹Capacities include allowance for corrosion over a 50-year service life in accordance with Section 3.9 of AC308.

²Refer to Figure 6C and Table 6C for the code-prescribed minimum concrete cover dimensions.

³Refer to Figure 6C and Table 6C for the required full concrete cover dimensions such that concrete related limit states do not govern the bracket capacity.

⁴Concrete strength is the specified compressive strength at 28 days.

TABLE 6B—CONCRETE FIXED HEAD BRACKET ALLOWABLE CAPACITIES SEISMIC DESIGN CATEGORIES C, D, E AND F¹

Concrete Fixed Head Bracket	Steel Finish	Concrete Compressive Strength ⁴ , psi	Axial Compression		Axial Tension		Lateral Load	
			Min. Concrete Cover ⁽²⁾	Full Concrete Cover ⁽³⁾	Min. Concrete Cover ⁽²⁾	Full Concrete Cover ⁽³⁾	Min Concrete Cover ⁽⁴⁾	Full Concrete Cover
			(kips)	(kips)	(kips)	(kips)	(kips)	(kips)
6 inch	Plain	3500	10.54	23.55	1.37	7.36	1.1	2.98
		4000	11.26	26.92	1.48	7.36	1.2	3.18
	Galvanized	3500	10.57	23.95	1.39	8.73	1.1	3.79
		4000	11.30	27.37	1.48	8.73	1.2	4.05
8 inch	Plain	3500	8.96	23.55	1.78	6.72	1.3	3.39
		4000	8.96	26.92	1.90	6.72	1.4	2.76
	Galvanized	3500	10.99	23.95	1.78	8.25	1.3	3.39
		4000	10.99	27.37	1.91	8.25	1.4	3.62

For SI: 1 inch = 25.4 mm, 1 kip = 4.448 kN, 1 psi=.

¹Capacities include allowance for corrosion over a 50-year service life in accordance with Section 3.9 of AC308.

²Refer to Figure 6C and Table 6C for the code-prescribed minimum concrete cover dimensions.

³Refer to Figure 6C and Table 6C for the required full concrete cover dimensions such that concrete related limit states do not govern the bracket capacity.

⁴Concrete strength is the specified compressive strength at 28 days.

TABLE 6C—CONCRETE FIXED HEAD BRACKET CONCRETE COVERS^{1,5}

Concrete Fixed Head Bracket	Steel Finish	Concrete Specified Compressive Strength ⁴	Minimum Concrete Covers ² , inches			Full Concrete Covers ³ , inches									
						For Axial Compression			For Axial Tension ⁶			For Lateral			
			C ^{5,6}	B	X1	X2	B	X1	X2	B	X1	X2	B	X1	X2
6 inch	Plain	3500	4	14	3	4	19.8	3	7	18	6	4	18	6	4
		4000	4	14	3	4	20.4	3	7.5	18	6	4	18	6	4
	Galv	3500	4	14	3	4	20	3	7	19	7	4	20	7	4
		4000	4	14	3	4	20.6	3	7.5	19	7	4	20	7	4
8 inch	Plain	3500	4	16	3	4	20.5	3	6.5	19	6	4	20	6	4
		4000	4	16	3	4	21.1	3	7	18	5	4	18	5	4
	Galv	3500	4	16	3	4	20.7	3	6.3	20	6	4	20	6	4
		4000	4	16	3	4	21.2	3	7	19	6	4	20	6	4

For SI: 1 inch = 25.4 mm, 1 psi = 6.895 kPa, 1 kip= 4.48 kN.

¹See Figure 6C for concrete cover designations.

²Minimum concrete covers are prescribed in IBC Section 1810.3.11.

³Full concrete covers are determined to ensure that concrete related limit states do not govern the bracket capacities.

⁴Concrete strength is the specified compressive strength at 28 days.

⁵Dimensions B and C apply to both bracket width and length directions.

⁶For dimension X1 determination, in accordance with Section 14.5.1.7 of ACI 318-19 under the 2021 IBC, Section 14.5.1.7 of ACI 318-14 under the 2018 and 2015 IBC and Section 22.4.7 of ACI 318-11 and ACI 318-08 under the 2012 and 2009 IBC, concrete is assumed cast against soil, and a 2-inch extra concrete thickness is included in X1.

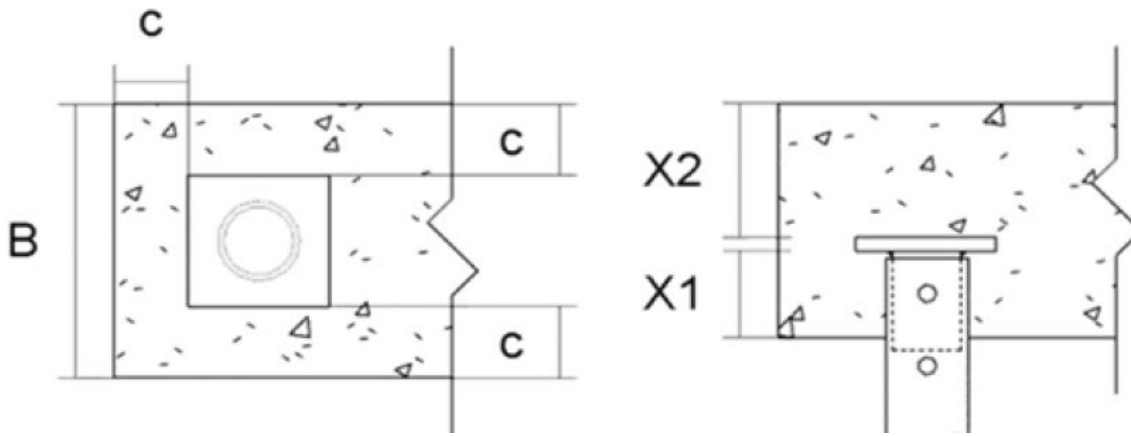

FIGURE 6C—CONCRETE FIXED HEAD BRACKET CONCRETE COVERS DIAGRAM

TABLE 7—SHAFT ALLOWABLE CAPACITY⁽¹⁾ (kips)

Steel	Allowable Compression, kips					Allowable Tension, kips	Allowable Bending, kip-ft	Allowable Shear, kips	Maximum Installation Torque, ft-lb	
Plain	No. Of Couplers ⁵	Shaft Effective Unbraced Length (kLu) ^{2,3,4} , ft								
				0	5	10	15	20	21.2	4.3
	0	51.2	24.9	14.7	8.8	5.6				
	1	51.2	15.5	10.8	7.3	5.0				
	2	51.2	9.7	7.6	5.7	4.2				
Galvanized	No. Of Couplers ⁵	Shaft Effective Unbraced Length (kLu) ^{2,3,4} , ft					25.9	5.07	16.3	8135
			0	5	10	15				
	0	60.2	29.3	17.3	10.4	6.6				
	1	60.2	18.3	12.7	8.6	5.8				
	2	60.2	11.5	9.0	6.7	4.9				

For SI: 1 inch = 25.4 mm, 1 foot = 304.8 mm, 1 kip = 4.448 kN.

¹Capacities include allowance for corrosion over a 50-year service life in accordance with Section 3.9 of AC358 and presume the supported structure is braced in accordance with IBC Section 1810.2.2. Additionally, capacities account for bending stresses caused by a maximum inclination from vertical of 1 degree.

²Lu = total pile unbraced length in accordance with IBC Section 1810.2.1, including the length in air, water or in fluid soils, and the embedment length into firm or soft soil (non-fluid soil).

³K = effective length factor for shaft compression buckling consideration.

⁴kLu = Total effective unbraced length of the pile, where kLu = 0 represents a fully braced condition in that the total pile length is fully embedded in firm or soft soil and the supported structure is braced as noted in footnote 1, above.

⁵Total number of couplers within the total pile length.

TABLE 8—HELIX ALLOWABLE CAPACITY FOR AXIAL TENSION AND AXIAL COMPRESSION⁽¹⁾

Helical Plate Diameter, inches	Thickness, inch	Plain Steel Allowable Axial Tension and Axial Compression Capacity, kips	Galvanized Steel Allowable Axial Tension and Axial Compression Capacity, kips
10	0.375	47.39	54.05
12	0.375	52.13	59.46
14	0.375	51.50	58.75
16	0.5	52.84	58.24
18	0.5	53.59	59.07

For SI: 1 inch = 25.4 mm, 1 kip = 4.448 kN.

¹Capacities include allowance for corrosion over a 50-year service life.

TABLE 9—HELICAL PILE ALLOWABLE LATERAL SOIL CAPACITY^(1,2,3)

PILE MODEL	ALLOWABLE LATERAL CAPACITY	MINIMUM INSTALLATION DEPTH
	(lbs)	(ft)
Helical Pile with 10-inch helical plate diameter	1867	15

For SI: 1 lbs= 4.48 N, 1 ft= 305 mm.

¹Installation must be in accordance with Sections 4.1.5 and 4.2 of this report.

²Installation is limited to piles in very stiff clay with a minimum SPT of 26.

³For soil conditions other than very stiff clay, the lateral capacity of the pile must be determined by a registered design professional.

DIVISION: 31 00 00—EARTHWORK

Section: 31 63 00—Bored Piles

REPORT HOLDER:

PIEUX VISTECH/POSTECH SCREW PILES, INC.

EVALUATION SUBJECT:

POSTECH SCREW PILE FOUNDATION SYSTEM

1.0 REPORT PURPOSE AND SCOPE

Purpose:

The purpose of this evaluation report supplement is to indicate that the Postech Screw Pile foundation system, described in ICC-ES evaluation report ESR-4735, has also been evaluated for compliance with the codes noted below.

Applicable code editions:

- 2019 *California Building Code* (CBC)

For evaluation of applicable chapters adopted by the California Office of Statewide Health Planning and Development (OSHPD) AKA: California Department of Health Care Access and Information (HCAI) and the Division of State Architect (DSA), see Sections 2.1.1 and 2.1.2 below.

- 2019 *California Residential Code* (CRC)

2.0 CONCLUSIONS

2.1 CBC:

The Postech Screw Pile foundation system, described in Sections 2.0 through 7.0 of the evaluation report ESR-4735, complies with CBC Chapter 18, provided the design and installation are in accordance with the 2018 *International Building Code*® (IBC) provisions noted in the evaluation report and the additional requirements of CBC Chapters 16, 17 and 18, as applicable.

2.1.1 OSHPD: The applicable OSHPD Sections and Chapters of the CBC are beyond the scope of this supplement.

2.1.2 DSA: The applicable DSA Sections of the CBC and Chapters are beyond the scope of this supplement.

2.2 CRC:

The Postech Screw Pile foundation system, described in Sections 2.0 through 7.0 of the evaluation report ESR-4735, complies with CRC Chapter 3, provided the design and installation are in accordance with the 2018 *International Residential Code*® (IRC) provisions noted in the evaluation report.

This supplement expires concurrently with the evaluation report, reissued October 2024.

DIVISION: 31 00 00—EARTHWORK

Section: 31 63 00—Bored Piles

REPORT HOLDER:

PIEUX VISTECH/POSTECH SCREW PILES, INC.

EVALUATION SUBJECT:

POSTECH SCREW PILE FOUNDATION SYSTEM

1.0 REPORT PURPOSE AND SCOPE

Purpose:

The purpose of this evaluation report supplement is to indicate that the Postech Screw Pile foundation system, described in ICC-ES evaluation report ESR-4735, has also been evaluated for compliance with the codes noted below.

Applicable code editions:

- 2020 Florida Building Code—Building
- 2020 Florida Building Code—Residential

2.0 CONCLUSIONS

The Postech Screw Pile foundation system, described in Sections 2.0 through 7.0 of ICC-ES evaluation report ESR-4735, complies with the *Florida Building Code—Building* or the *Florida Building Code—Residential*, as applicable, provided the design requirements are determined in accordance with the *Florida Building Code—Building* or the *Florida Building Code—Residential*, as applicable. The installation requirements noted in ICC-ES evaluation report ESR-4735 for the 2018 *International Building Code*® meet the requirements of the *Florida Building Code—Building* or the *Florida Building Code—Residential*, as applicable.

Use of the Postech Screw Pile foundation system for compliance with the High-Velocity Hurricane Zone provisions of the *Florida Building Code—Building* or the *Florida Building Code—Residential* has not been evaluated and is outside the scope of this supplemental report.

For products falling under Florida Rule 61G20-3, verification that the report holder's quality assurance program is audited by a quality assurance entity approved by the Florida Building Commission for the type of inspections being conducted is the responsibility of an approved validation entity (or the code official when the report holder does not possess an approval by the Commission).

This supplement expires concurrently with the evaluation report, reissued October 2024.