

ICC-ES Evaluation Report

ESR-4639

Reissued February 2024

This report also contains:

- LABC Supplement

Subject to renewal February 2025

ICC-ES Evaluation Reports are not to be construed as representing aesthetics or any other attributes not specifically addressed, nor are they to be construed as an endorsement of the subject of the report or a recommendation for its use. There is no warranty by ICC Evaluation Service, LLC, express or implied, as to any finding or other matter in this report, or as to any product covered by the report.

Copyright © 2024 ICC Evaluation Service, LLC. All rights reserved.

<p>DIVISION: 05 00 00—METALS</p> <p>Section: 05 52 00—Metal Railings</p> <p>Section: 05 73 13—Glazed Decorative Metal Railings</p> <p>DIVISION: 08 00 00—OPENINGS</p> <p>Section: 08 81 00—Glass Glazing</p> <p>Section: 08 88 00—Special Function Glazing</p>	<p>REPORT HOLDER:</p> <p>GLASS VICE USA LLC</p>	<p>EVALUATION SUBJECT:</p> <p>GLASS VICE CLEARLINE® GLASS PANEL RAILING AND GLASS BALUSTER SYSTEMS</p>	
--	---	--	---

1.0 EVALUATION SCOPE

Compliance with the following codes:

- 2018, 2015, 2012 and 2009 [International Building Code® \(IBC\)](#)
- 2018, 2015, 2012 and 2009 [International Residential Code® \(IRC\)](#)
- 2018 [International Swimming Pool and Spa Code® \(ISPSC\)](#)

For evaluation for compliance with codes adopted by Los Angeles Department of Building and Safety (LADBS), see [ESR-4639 LABC and LARC Supplement](#).

Properties evaluated:

- Structural
- Durability

2.0 USES

The Glass Vice Clearline® Glass Panel Railing and Glass Baluster Systems described in this report are intended for interior and exterior use in residential, commercial and industrial applications for guards along balconies, porches, mezzanines, stairs and similar locations, except where vehicle impact resistance is required. The system may also be used as a pool or spa barrier. The system is compatible with all construction types. Use in Wind-borne Debris Regions is outside the scope of this report.

The Glass Vice Clearline® Glass Panel Railing and Glass Baluster Systems described in this report must be constructed using monolithic tempered or laminated tempered glass within the limitations specified in this report. See Section 4.1.5.1 in this report for limitations on the installation of laminated tempered glass.

The system may be installed up to the lesser of a total height of 46 inches (117 cm) or as shown on [Table 2](#) without a top rail or handrail when 9/16-inch thick (14.3 mm), 5/8-inch thick (15.5 mm) or 11/16-inch thick

(17.5 mm) laminated tempered glass panels with an interlayer meeting the requirements of Section 3.2.1 are used. Installation without a top rail complies with the Exceptions noted in IBC Section 2407.1.2 and 2018 IRC Section R308.4.4.1.

The system may also be installed without a top rail or handrail with monolithic or laminated glass panels when used as a spa or pool barrier and installed in accordance with Section 4.2.6. This use is limited to configurations in which the system is not required to function as a guard or handrail.

3.0 DESCRIPTION

3.1 General:

The Glass Vice Clearline® Glass Panel Railing and Glass Baluster Systems allow for the construction of frameless glass balustrade guards, wind breaks and pool barriers. The systems include the monolithic tempered glass (to be provided by others) or laminated tempered glass (to be provided by others), the railing, the glass clamp, the glass bracket and the fastening into the substrate. The Glass Vice Clearline® system uses a proprietary glass clamp ([Figure 1](#)) cast from Duplex 2205 (UNS S32205) complying with ASTM A890/A890M, to anchor and fully support 1/2-inch (12.7 mm) or 5/8-inch (15.5 mm) monolithic tempered glass or, 9/16-inch (14.3 mm), 5/8-inch (15.5 mm) or 11/16-inch (17.5 mm) laminated tempered glass balustrades. Installations may have a stainless steel handrail located between 34 and 42 inches (864 and 1067 mm) above floor surface as appropriate for the installation. A handrail or top rail must be installed when the monolithic tempered glass balustrade is required for fall protection to comply with IBC 2407.1. The balustrade system must be anchored into wood, concrete or steel substrates with a Clearline® clamp and appropriate fasteners as shown on [Figures 2](#) through [5](#) in this report based on the substrate and location of attachment. The clamps are supplied without the fasteners to the substrate for installations to steel or concrete. The Clearline® clamps are the same for all glass thicknesses and will accept glass with a true thickness between 0.355 inches and 0.72 inches.

3.2 Material:

The glass must be fully tempered glass complying with ASTM C1048, ANSI Z97.1 and CPSC 16 CFR 1201 (procured separately). The minimum thickness of the tempered glass for each guard system is as required for the loading conditions; refer to [Tables 1](#) and [2](#) of this report.

The handrail is manufactured out of stainless steel material and is 1½-inch by 1-inch (38.1 mm by 25.4 mm) tube. The handrail must be connected to the glass balustrade with a proprietary bracket made from 316 stainless steel supplied by Glass Vice per ESR-3563.

The Glass Vice Clearline® glass clamp is composed of an adjustable clamping system which is made up of duplex 2205, 6 adjustable set screws, 50 mm by 95 mm by 3mm thick Polyethylene plastic strips, bonded to two duplex shims x 6mm thick with tapered ends. The clamp is 55/16 inches (135.1 mm) in height x 4 3/4 inches (121mm) wide.

Connection to structural steel uses four M10 stainless steel (SS) threaded rods, ISO 3506-1 Class A4 secured into either tapped holes or with nuts and washers as illustrated on [Figure 2](#), fasteners not by Glass Vice.

Connection to concrete substrate uses four M10 stainless steel (SS) threaded rods, ISO 3506-1 Class A4, which must be installed into the concrete substrate with Hilti HIT-RE 500 V3 adhesive ([ESR-3814](#)). See [Figure 3](#), in this report. Installation of the rods must comply with the installation details noted in ESR-3814. Adhesive and fasteners are not supplied by Glass Vice.

For installation into wood, four M10 hanger screws are used per [Figure 4](#) or four M10 lag screws with 1 inch (25.4mm) diameter spacers per [Figure 5](#).

3.2.1 Laminated Tempered Glass: The laminated tempered glass must be fully tempered laminated glass complying with ASTM C1172, ANSI Z97.1 and CPSC 16 CFR 1201 (glass procured separately--not supplied by Glass Vice). The fully laminated tempered glass used in the fabrication must comply with ASTM C1048. The ionoplast interlayer must be 0.06-inch (1.54 mm) thick, and must have a minimum shear modulus of 1640 psi (11.3 MPa) for $T \leq 122^{\circ}\text{F}$ (50°C) and a minimum ultimate tensile strength of 5000 psi (34.5 MPa) for $T \leq 122^{\circ}\text{F}$ (50°C). The minimum glass thicknesses specified in ASTM C1036 and C1300 are modified as specified in this report. All glass edges must be polished.

3.2.1.1 The 9/16-inch (14.3mm) laminated tempered glass must be made from 1/4-inch (6 mm) nominal tempered glass. The overall true thickness of the laminated tempered glass must be between 0.50-inch (12.7 mm) minimum. Evidence of compliance with these requirements must be submitted to the code official.

3.2.1.2 The $\frac{5}{8}$ -inch (15.5 mm) laminated tempered glass must be made from one ply of $\frac{1}{4}$ -inch (6 mm) nominal tempered glass with a minimum true thickness of 0.219 inch (5.56 mm) and $\frac{5}{16}$ -inch (8 mm) nominal tempered glass. The overall true thickness of the laminated tempered glass must be 0.558 inch (14.17 mm) minimum. Evidence of compliance with these requirements must be submitted to the code official.

3.2.1.3 The $\frac{11}{16}$ -inch (17.5 mm) laminated tempered glass must be made from plies of $\frac{5}{16}$ -inch (8 mm) nominal tempered glass. The overall true thickness of the laminated tempered glass must be between 0.618 inch (14.17 mm) minimum and 0.71 inch (18.0mm) maximum. Evidence of compliance with these requirements must be submitted to the code official.

3.3 Durability:

The materials incorporated in the system described in this report are inherently corrosion-resistant. The material type specified must be appropriate for the environment of the installation. Information verifying the durability must be submitted to the code official, when requested.

4.0 DESIGN AND INSTALLATION

4.1 Design:

4.1.1 Loading: The applicable project-specific loads must be identified. Minimum required loads are the following:

- 50 plf (0.73kN/m) live load on the top rail or handrail in any direction except where exempted based on occupancy
- 200 lb (0.89kN) live load on the top rail or handrail in any direction
- 50 lb (0.22kN) live load on one square foot at any location perpendicular to the glass balustrade

Deflection of the top rail when subjected to a 200-pound (0.89kN) concentrated live load is less than 1 inch (25.4 mm) for the following system configurations:

- System height of 36 inches (91.4 cm) with total glass height of 40 inches (101.6 cm) or less for $\frac{9}{16}$ -inch-thick (13.5 mm) laminate glass panels or $\frac{1}{2}$ " (12mm) monolithic tempered glass panels and continuous top rail.
- System height of 42-inches (106.7 cm) with total glass height of 46 inches (116.8 cm) or less for $\frac{5}{8}$ -inch thick (15.5 mm) laminate glass panels and continuous top rail.
- System height of 46 inches (116.8 cm) with total glass height of 50 inches (127.0 cm) or less for $\frac{11}{16}$ -inch thick (17.5 mm) laminate glass panels or $\frac{5}{8}$ " (16mm) monolithic tempered glass panels.

Deflection of the top rail when subjected to a 50 plf (0.73kN/m) live load is less than 1 inch (25.4mm) for the glass types and configurations shown in [Table 2](#).

Glass panel heights are limited to the maximum allowable heights listed in [Table 2](#) when consideration of the 50 plf (0.73KMN/m) live load is required.

The required wind load must be determined by a qualified design professional based on the project-specific conditions, taking into account the balustrade location on the structure, and must not exceed the values shown in [Table 1](#) of this report, as applicable. For installations in accordance with the IRC, the 50 plf (0.73 kN/m) top rail load is not applicable.

4.1.2 Monolithic Tempered Glass Balustrade System: The glass thickness, panel size and system height for the $\frac{1}{2}$ -inch (12 mm) and $\frac{5}{8}$ -inch (16 mm) monolithic tempered glass must be designed for the loading conditions, see [Tables 1](#) and [2](#) in this report. The required spacing between the glass lites must be $\frac{25}{32}$ -inch (20 mm) minimum to $\frac{13}{16}$ -inch (30 mm) maximum for installation of the handrail brackets. A handrail or top rail must be installed with the monolithic tempered glass balustrade system unless installed as noted in Section 4.2.6 of this report.

4.1.3 Glass Vice Clearline®: The Glass Vice Glass Clamp and fasteners that are required for each mounting option are shown in [Figures 1](#) through [5](#) of this report. The Glass Vice Clearline® Clamp must be installed in accordance with the manufacturer's published installation instructions and this report.

4.1.4 Holes and Notches for Monolithic Tempered Glass: Holes and notches must not be located within the first third of the balustrade height from the base. Holes and notches must conform to ASTM C1048. Holes or notches located within the first third of the balustrade height from the base shoe are outside the scope of this report.

4.1.5 Laminated Tempered Glass:

4.1.5.1 Laminated Tempered Glass Loading: Installation of the laminated tempered glass is allowed for locations where the design loading condition is either wind load alone or 200-pound (0.89 kN) concentrated load, and/or the 50 plf (0.73 kN/m) handrail load is applicable. Maximum allowable wind loads are as indicated in [Table 1](#) of this report. Installation of laminated tempered glass with the handrail brackets is permitted.

4.1.5.2 Laminated Glass Baluster System: The glass thickness, panel size and system height must be as indicated in [Tables 1](#) and [2](#) of this report. The required spacing between the glass lites is $^{25}/_{32}$ inch (20 mm) minimum to $^{13}/_{16}$ inch (30 mm) maximum for installation of the H-bracket per ESR-3563. When required to support the 200 lb (0.89 kN) concentrated load, the adjacent lites must be connected together with the supplied H-bracket installed within 4 inches (102 mm) from the top edge of the glass unless a top rail is installed, or the joint is butt glazed full height with structural silicone. Corner lites must be connected together with the Glass Vice corner H-bracket, top rail or structural silicone. The end lites must be attached to a supporting structure or post capable of supporting 200 pounds (0.89kN) using an acceptable connection detail. The connection between glass lites is not required when designed for wind load only and a 2-inch (51 mm) minimum gap between lites is maintained.

4.1.5.3 Mixed Panel Widths: Glass panels of different widths are permitted with the allowable wind load based on the longest glass panel or for the specific wind load on each panel.

4.1.5.4 Holes and Notches: Holes and notches in the laminated tempered glass are outside the scope of this report.

4.2 Installation:

4.2.1 General: Installation of the Glass Vice glass panel railing and guards must comply with the manufacturer's published instructions, this report and 2018 and 2015 IBC Sections 1015 and 1607.8.1; 2012 IBC Sections 1013 and 1607.8.1; or 2009 IBC Sections 1013 and 1607.7.1, as applicable. Handrails must comply with 2018 and 2015 IBC Section 1014; 2012 and 2009 IBC Section 1012; or 2018, 2015, 2012 and 2009 IRC Section R311.7.8, as applicable. Glass lite dimensions for the glass must be within the limits shown in [Figures 6](#) of this report for residential and other installations exempt from the 50 plf live load, [Figure 7](#) of this report for all installations subject to the 50 plf live load, or [Figure 8](#) for pool/spa enclosures and wind screens.

4.2.2 Installation of Glass Vice Clearline® to Concrete:

4.2.2.1 Concrete strength, condition and minimum dimensions must be as indicated in [Figure 3](#).

4.2.2.2 Four holes must be drilled into concrete for the installation of the Clearline® clamps. The center line of each hole must not be closer than 2.5 inches (63.5 mm) from the bottom edge and 2 inches (50 mm) from the top edge of the slab and no less than 5 inches (127 mm) from the slab end. The holes must be between 12 mm ($^{15}/_{32}$ inch) and 20 mm ($^{25}/_{32}$ inch) in diameter and drilled to the minimum depth of 3-9/16 inches (90 mm). After cleaning the holes, each hole must be filled with Hilti-HIT-RE 500 V3 adhesive. Installation must be into dry holes only and for use in temperature range A (130°F short-term maximum and 110°F maximum long-term temperature). Hole cleaning and adhesive installation must comply with the manufacturer's published installation instructions and [ESR-3814](#). Special inspection is required for installation of adhesive anchors, as noted in [ESR-3814](#).

4.2.3 Installation of Glass Vice Clamp to Wood: Wood may have a moisture content over 19 percent at the time of fabrication and in service and must be a species and grade with specific gravity greater than 0.46. Supporting wood structure must be constructed to support the imposed moments from the Glass Vice Clamps. The Clearline® clamp must be attached as shown on [Figures 4](#) or [5](#) or designed for the specific project conditions.

4.2.4 Installation of Glass Vice Clamp to Steel: Supporting steel member must be constructed to support the imposed moments from the Glass Vice Clamps. The Clearline® clamp must be attached as shown on [Figure 2](#) or designed for the specific project conditions.

4.2.5 Handrail Installation: Where required to provide fall protection, along stairs or other locations requiring an installed handrail, the handrail must be installed at the required height using the brackets and handrail from [ESR-3563](#).

4.2.5.1 Handrails must be installed from the finish floor to the top of the handrail no less than 34 inches to 38 inches (863.6 to 965.2 mm) maximum.

4.2.5.2 Handrail brackets are designed for use with a square, rectangular or flat bottom cross section with minimum $^{15}/_{8}$ -inch (38 mm) width complying with the dimensional and structural requirements of 2018 and 2015 IBC Section 1014 (2012 and 2009 IBC Section 1012), IRC R311.7.8.3.

4.2.6 Pool or Spa Barrier Applications: When installed as a pool or spa barrier in compliance with 2018 ISPC Section 305 and 2015, 2012, and 2009 IBC Section 3109.4.1, the top of glass must be a minimum of 48 inches (1219 mm) above grade on the side facing away from the pool. Minimum glass thickness shall be as required for the design wind loads per [Table 1](#) for the combination of glass panel height and length, monolithic or laminated, tempered glass. Maximum lite width must comply with the allowable width shown in [Figure 8](#) of this report and for the design wind loads per [Table 1](#) of this report, as applicable. When installed without a top rail the glass joints must be connected together with glass H brackets at 42 inches (1067 mm) above the walking surface or butt glazed full height with structural silicone. Refer to [Figure 8](#) of this report.

4.2.7 Wind Screen or Divider Applications: When installed to act as a wind screen, divider or similar use not intended to provide fall protection the installation must be as detailed in section 4.2.6 except there is no minimum height requirement.

For installations with a handrail, system deflection for a 50 plf (0.73KN/m) live load applied to the handrail is less than 1 inch (25.4 mm) for the glass type and handrail height shown on [Table 2](#).

5.0 CONDITIONS OF USE:

The Glass Vice Clearline® Glass Panel Railing and Glass Baluster Systems described in this report complies with, or is a suitable alternative to what is specified in, those codes listed in Section 1.0 of this report, subject to the following conditions:

- 5.1 The product is limited to installation where it is not subjected to vehicle impacts.
- 5.2 Installation must comply with this report and the manufacturer's published installation instructions. When the manufacturer's instructions are in conflict with this report, this report shall govern.
- 5.3 The systems described in this report must not be used in Wind-borne Debris Regions. Use of The Glass Vice Clearline® glass panel railing and glass baluster systems in Wind-borne Debris Regions is outside the scope of this report.
- 5.4 All glass must be fully tempered, fabricated, and inspected in accordance with ASTM C1048. Laminated tempered glass must also comply with ASTM C1172. The glass fabricator must provide certification of compliance with Section 2407.1 of the IBC and ASTM C1048. Glass must be procured directly from a qualified glass fabricator and is not produced or supplied by Glass Vice Holdings USA LLC.
- 5.5 The supporting structure must be designed and constructed to support the loads imposed by the glass balustrade system in accordance with the applicable code. The anchorage of the Clearline® panel railing and glass baluster system to the supporting structure must be as specified in this report. Drawings and design details for the Glass Vice Clearline® system must be included on the construction plans submitted to the code official for approval. The drawings and details must be prepared by a registered design professional where required by the statutes of the jurisdiction in which the project is constructed.
- 5.6 Monolithic fully tempered glass is permitted to be used in handrails and guardrails where there is not a walking surface beneath them or the walking surface is permanently protected from the risk of falling glass, as noted under the exception in Section 2407.1 of the 2018 and 2015 IBC.
- 5.7 The Glass Vice Clearline® Panel Railing and Balustrade Systems excluding anchorage components and the glass are supplied by Glass Vice Holdings USA LLC.

6.0 EVIDENCE SUBMITTED

Data in accordance with the [ICC-ES Acceptance Criteria for Glass Railing and Balustrade Systems \(AC439\)](#), approved April 2019.

7.0 IDENTIFICATION

- 7.1 The Glass Vice Panel Railing and Glass Baluster Systems described in this report are identified by a stamp on the packaging bearing the manufacturer's name (Glass Vice) product description or part number, and the ICC-ES evaluation report number (ESR-4639).
- 7.2 The report holder's contact information is the following:

GLASS VICE HOLDINGS USA LLC
14045 KIRKHAM WAY, SUITE 106
POWAY, CALIFORNIA 92064
(858) 539-6520
www.glassvice.com

TABLE 1—(ASD) ALLOWABLE WIND LOAD FOR TEMPERED GLASS PANELS^{1,2,3}

Glass Panel Width (inches)		74.8	60	48	36	30	24
Stress concentration factor, C		2.51	2.09	1.76	1.45	1.39	1.42
Glass thickness nominal	t _{eff} inch	Allowable wind load (W _{table}) in psf for 46 inches total glass height. H = 42.5 inches					
1/2 inch monolithic	0.469	22.5	27.0	32.0	38.9	40.5	39.7
9/16 inch nom. laminated	0.472	22.7	27.3	32.4	39.4	41.1	40.2
5/8 inch nom. laminated	0.484	23.9	28.7	34.1	41.4	43.2	42.3
5/8 inch monolithic	0.595	36.1	43.4	51.5	62.6	65.3	63.9
11/16 inch nom. laminated	0.60	36.7	44.1	52.4	63.6	66.4	65.0
2 Clamp adjustment factor ⁴ , C ₂		1.77	1.47	1.24	1.02	1.00	1.00

SI: 1 inch = 25.4 mm; 1 psf = 0.0479 kN/m²

1. Linear interpolation for glass panel widths between those shown is permitted.
2. Wind load for glass panel height H other than 42.5 inches projected height (46 inches total glass height): $W' = W_{table} * (42.5^2/H^2)$
Where H = total glass height - 3.5 inches
3. W = ASD allowable wind load (psf) . For LRFD strength design multiply allowable wind load by 1.67.
4. 3 clamps for 74.8 ≥ L ≥ 30. If Panels ≥ 30" are installed with two clamps, divide allowable wind load by C₂

TABLE 2—MAXIMUM PANEL HEIGHT ABOVE TOP OF CLAMP FOR LIVE LOAD OF 50 PLF^{1,3}

Glass Panel Width (inches)		74.8	60	48	36	30	24
Deflection Amplification factor, C_{Δ} =		1.58	1.49	1.36	1.14	1.11	1.12
Glass thickness nominal	t_{eff} inch	Maximum glass or handrail height for deflection = 1 inch					
1/2 inch monolithic	0.469	25.4	26.9	29.5	35.2	36.1	35.8
9/16 inch nom. laminated	0.472	25.5	27.1	29.7	35.4	36.3	36.0
5/8 inch nom. laminated	0.484	26.2	27.8	30.4	36.3	37.3	36.9
5/8 inch nom. laminated interior ²	0.552	29.9	31.7	34.7	41.4	42.5	42.1
5/8 inch monolithic	0.595	32.2	34.1	37.4	44.6	45.8	45.4
1 1/16 inch nom. laminated	0.60	32.4	34.4	37.7	45.0	46.2	45.8

SI: 1 inch = 25.4mm; 1 ft = 305mm; 1 lb = 4.45N;

1. Linear interpolation for glass panel widths between those shown is permitted.
2. Locations where temperature is maintained below 80°F.
3. 3 clamps for 74.8 ≥ L ≥ 30.

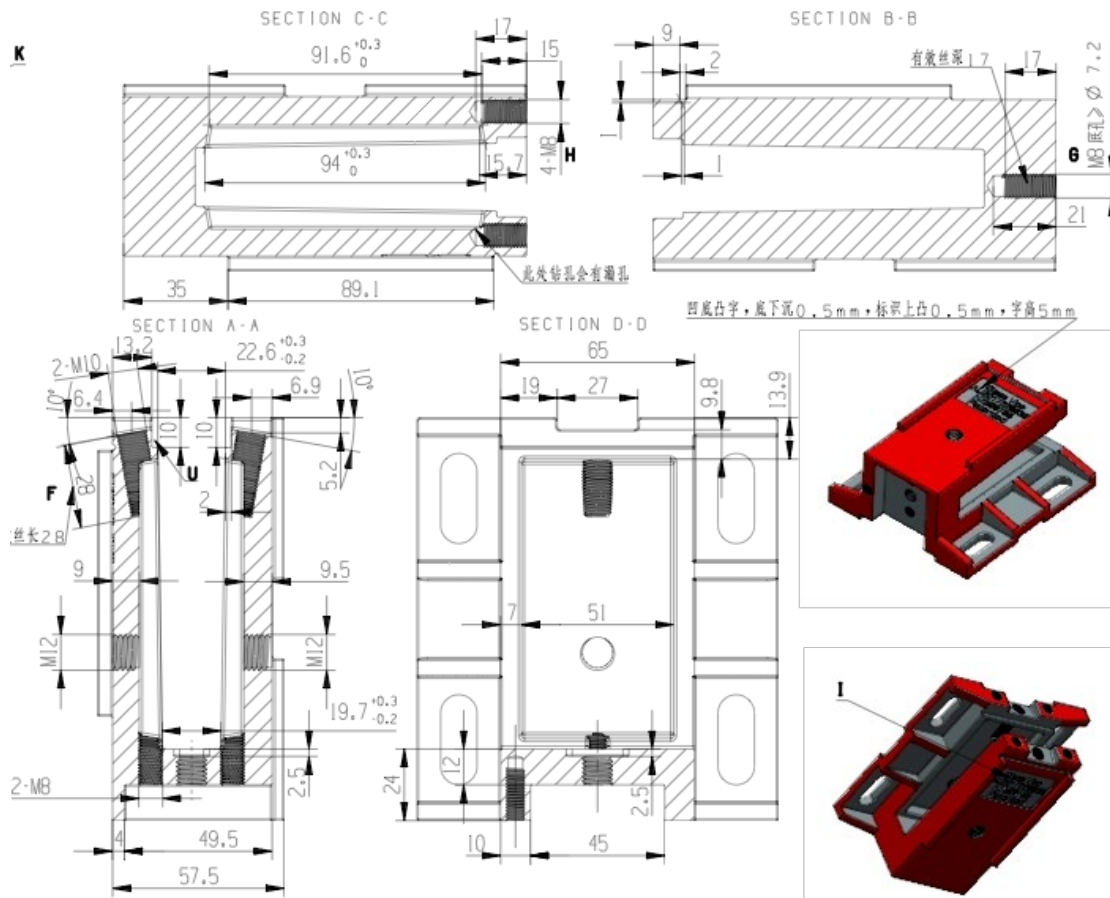

FIGURE 1—Clearline® CLAMP

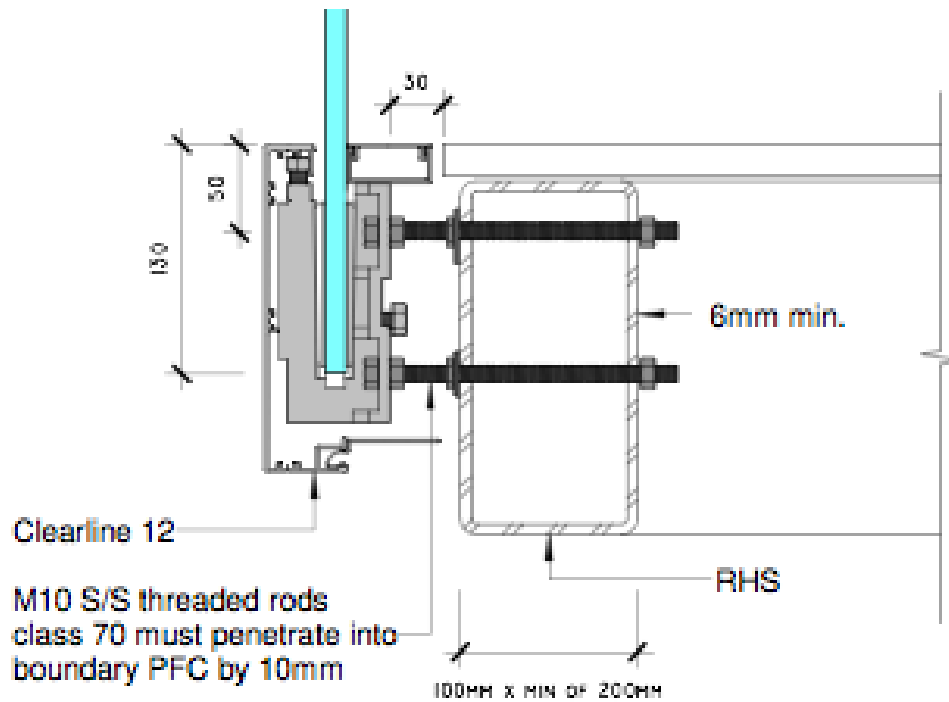
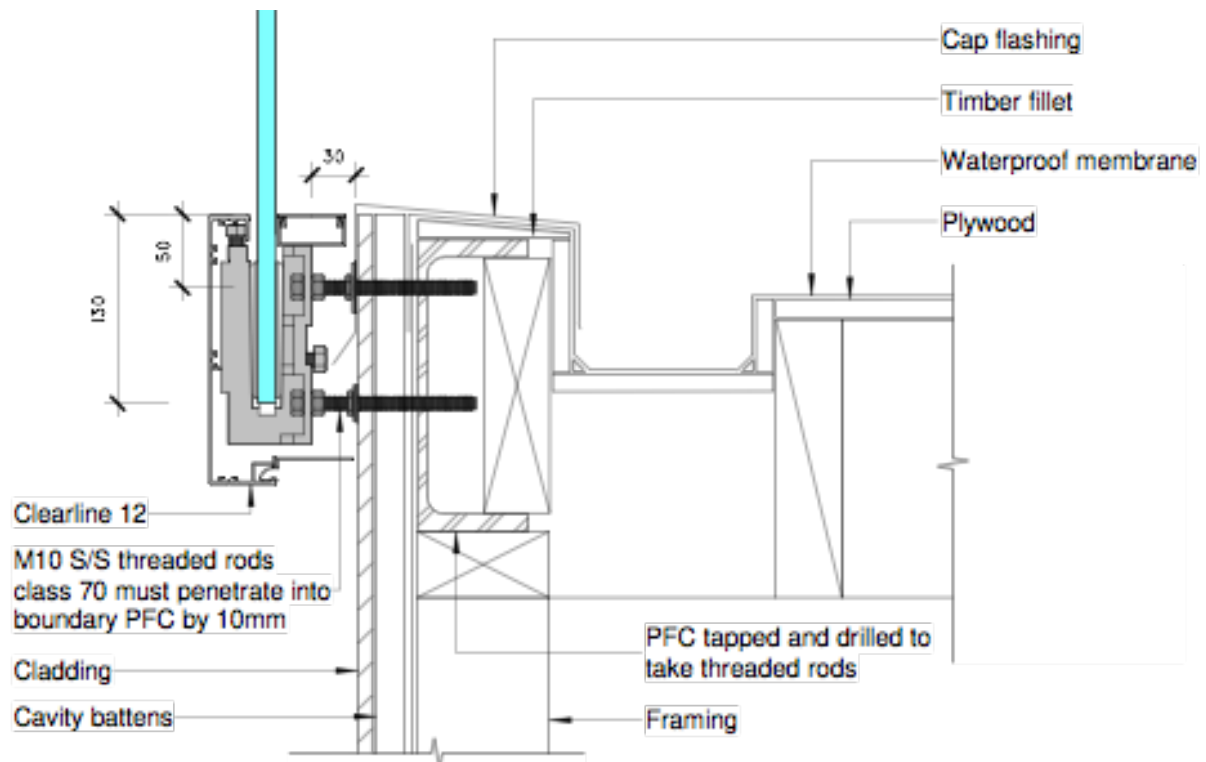
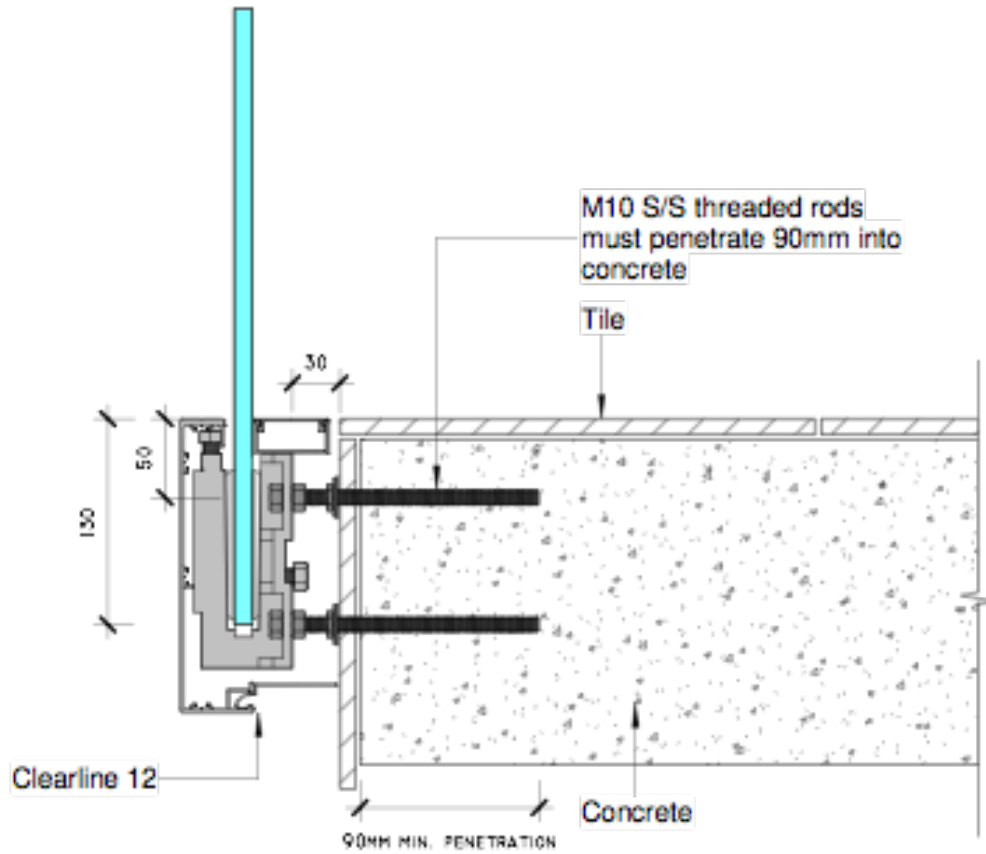

FIGURE 2—ANCHORAGE TO STRUCTURAL STEEL



Typical top edge distance is 2 inches to centerline of top anchor.
 Typical installation to concrete:
 10mm stainless steel threaded rod set with Hilti-HIT-RE 500 V3 adhesive.
 Embedment 3 9/16 inches minimum.
 For the standard installations covered in this report (50 plf top live load)
 Minimum loads: 2,420 lbs. tension live load on anchor pair (top 2 or bottom 2)
 75 lbs. shear (dead load) on anchor group.
 Loads are unfactored

Cast-in-Place anchors: 10mm rod with head or nut with 3-9/16 inches minimum embedment.

Alternative embedment and adhesive may be designed based on project specific conditions by a qualified licensed design professional.

FIGURE 3—ANCHORAGE TO CONCRETE

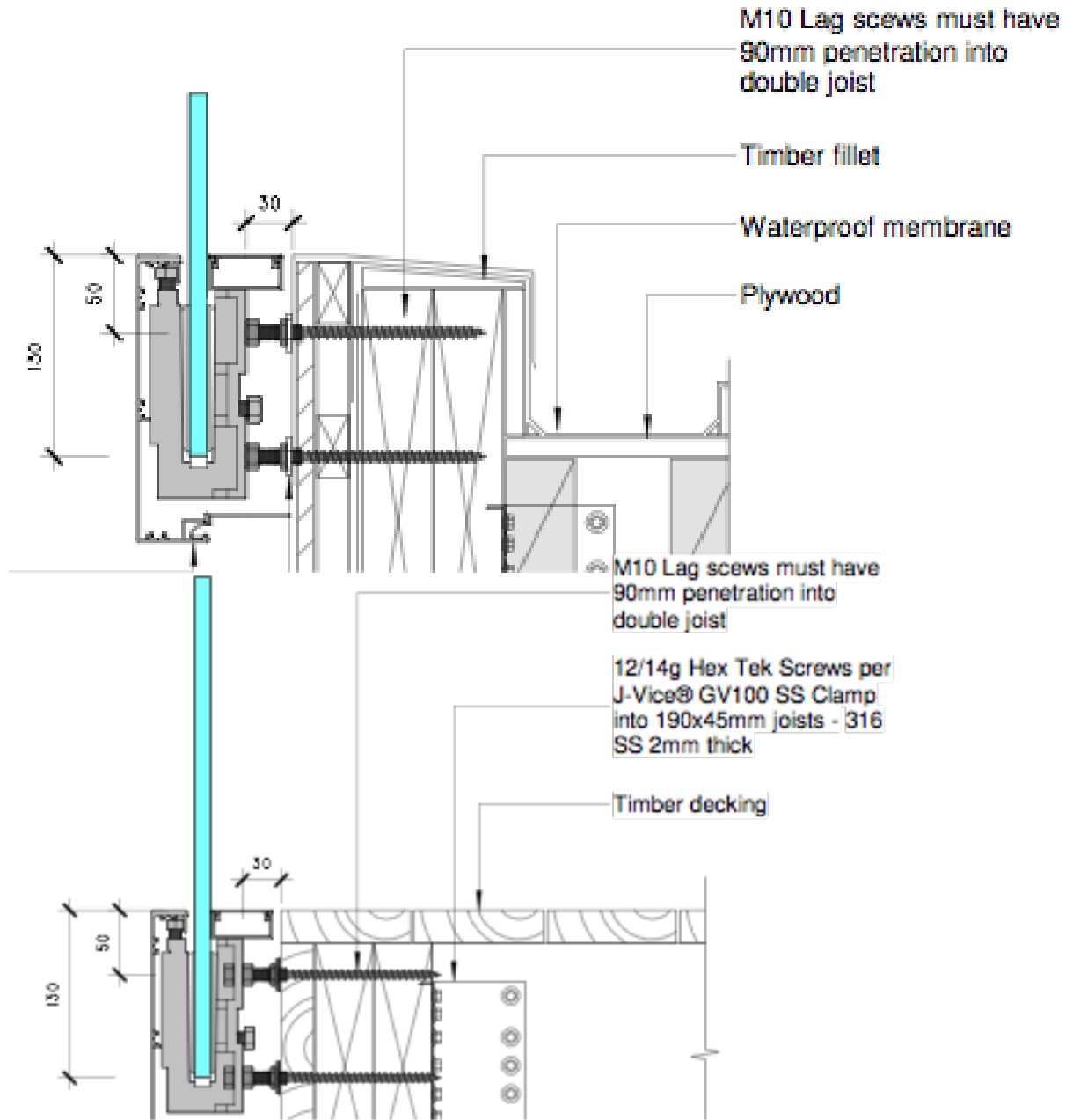

10mm or 3/8 inch Stainless steel hanger screw with minimum
 Use double nut on the standard threaded stud portion of hanger screw to secure the bracket.
 Minimum lag screw thread embedment into solid wood = 3.54 inches, 3 11/16 inches nominal with tip.
 If wood is subject to wetting, then the lag embedment length must be increased to 5 1/4 inches with tip.

FIGURE 4—ANCHORAGE TO WOOD

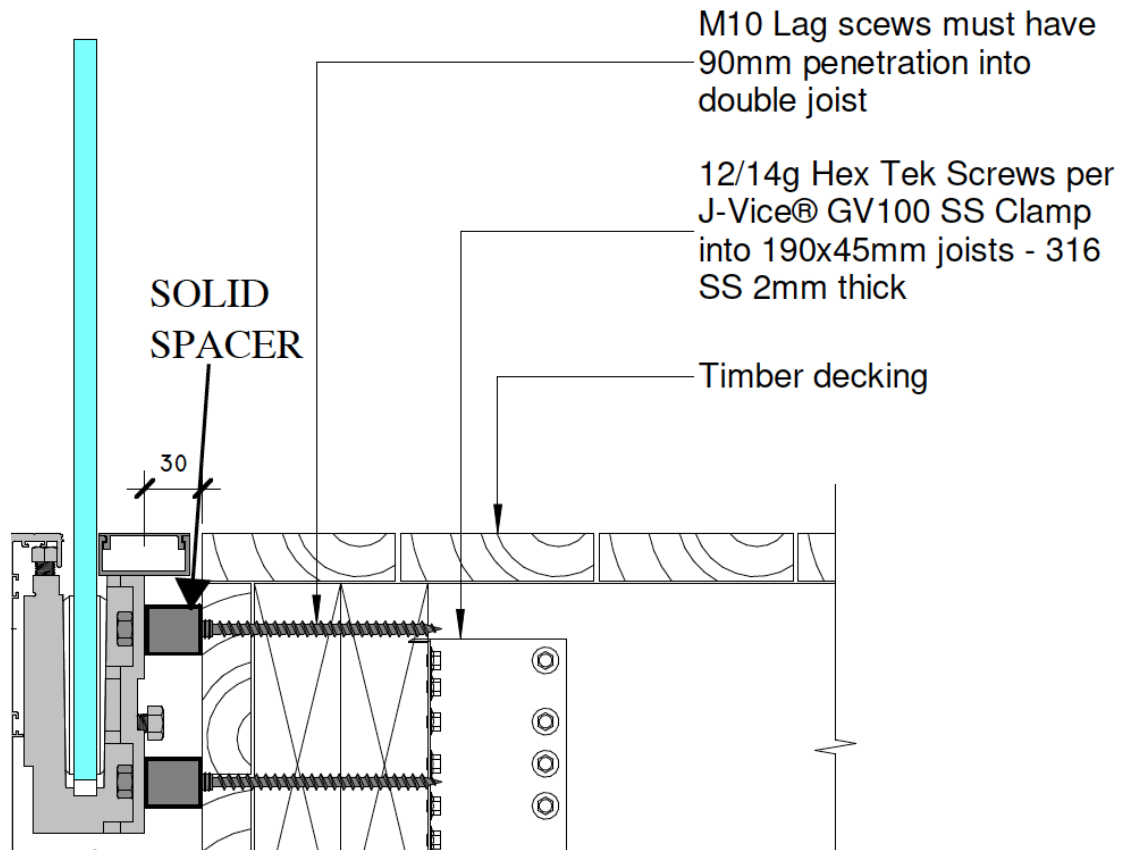

Use lag screw of sufficient length to achieve the required embedment, 3.54 inches (3 11/16 inches with tip). Typically, this will require a minimum length of at least 5 inches. If wood is subject to wetting, then the lag embedment length must be increased to 5 1/4 inches with tip.

Lag screw to be installed through 7/16 inch diameter hole in spacer. Spacer may be round or square minimum 1 inch diameter and $9/16 \text{ inch} \leq \text{length} \leq 3 \text{ inches}$.

The lag screw is secured to the clamp body so that the compression reaction is resisted by compression in the lag screw rather than by compression against the wood surface.

The spacer may also be used with the connection to steel or concrete.

The J-Vice® GV100 is shown for illustrative purposes to demonstrate the need to connect the framing to resist the loads and isn't part of this report.

FIGURE 5—ANCHORAGE TO WOOD: LAG SCREW WITH SPACER

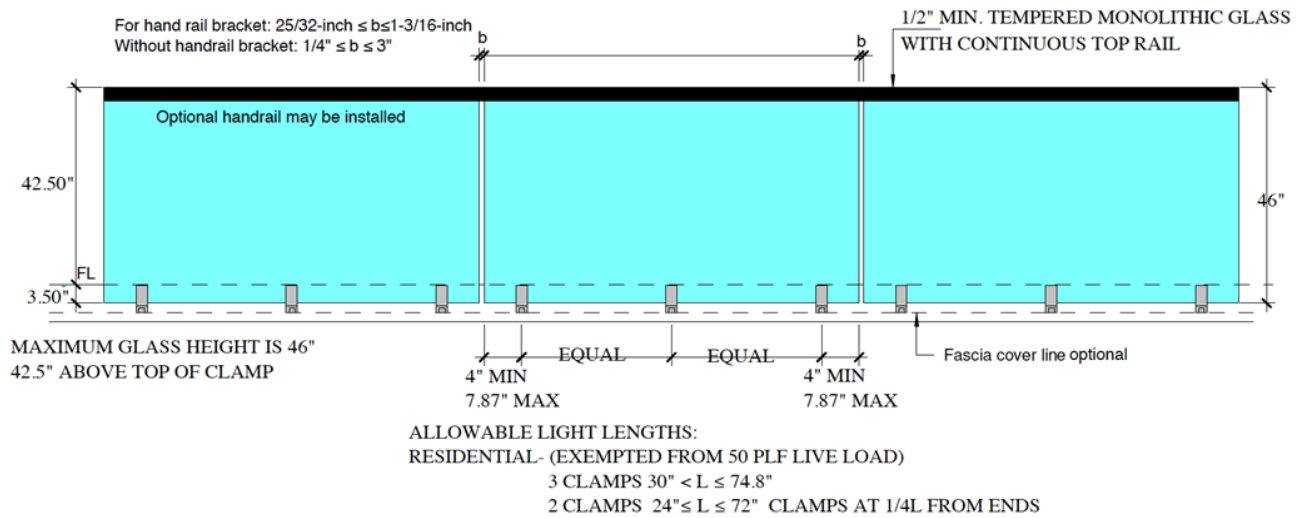

LAMINATED GLASS INSTALLATION

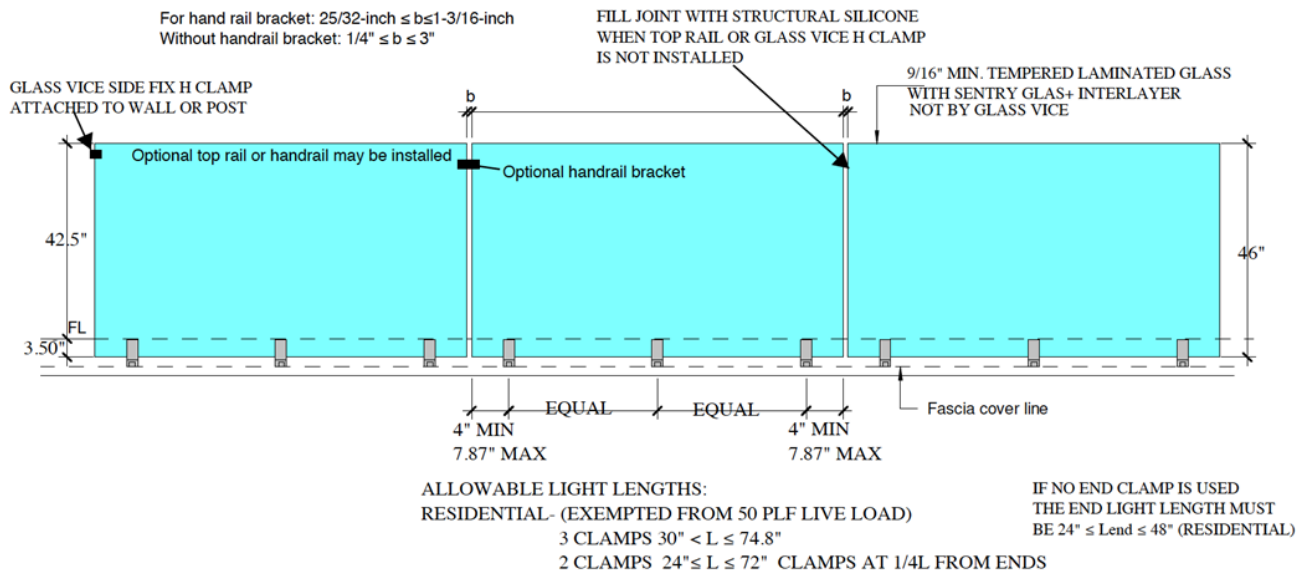

Installations exempt from the 50 plf top rail load case.

Maximum glass light size:

Residential: $24 \text{ inches} \leq L \leq 74.8 \text{ inches}$ x $h \leq 46 \text{ inches}$ or per [Table 1](#) Glass height must be adequate for the required minimum guard height above finish floor, typically 42½ inches with the 46 inches height.

For all glass thicknesses covered in this report two clamps per light may be used up to 72 inches panel length for R3 occupancies.

Bracket standoff distance: The typical installation is to install the bracket at 1 3/16 inches standoff from the fascia face. This may be increased to 3 inches maximum. Standoff distance may be reduced to a minimum of 9/16 inch.

Fascia Cladding: The cladding is non-structural and is optional. Omission of the cladding doesn't impact any other aspects of the system installation or performance.

FIGURE 6—TYPICAL INSTALLATION CONFIGURATION: RESIDENTIAL

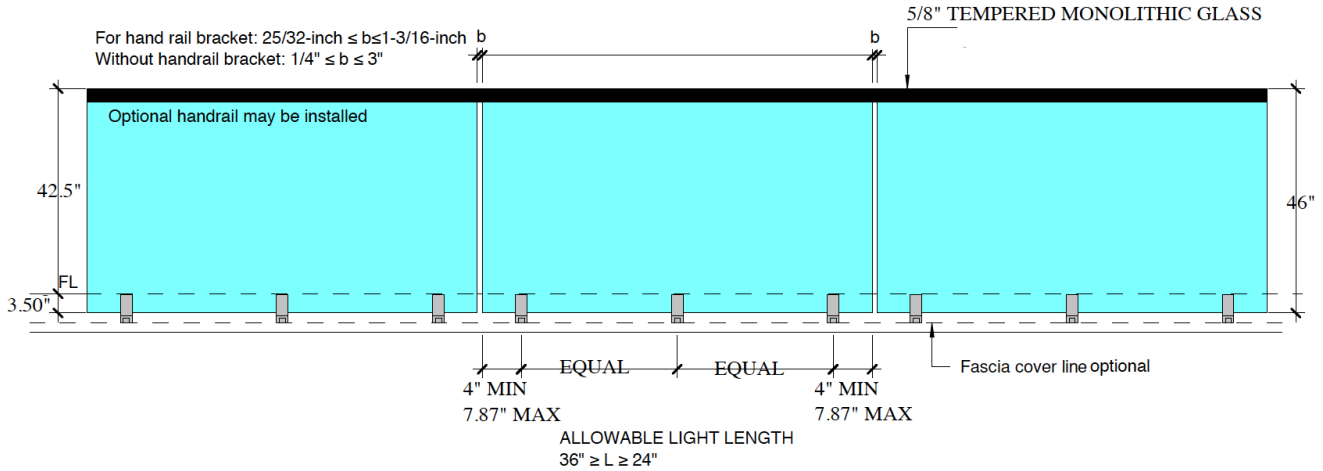

LAMINATED GLASS INSTALLATION

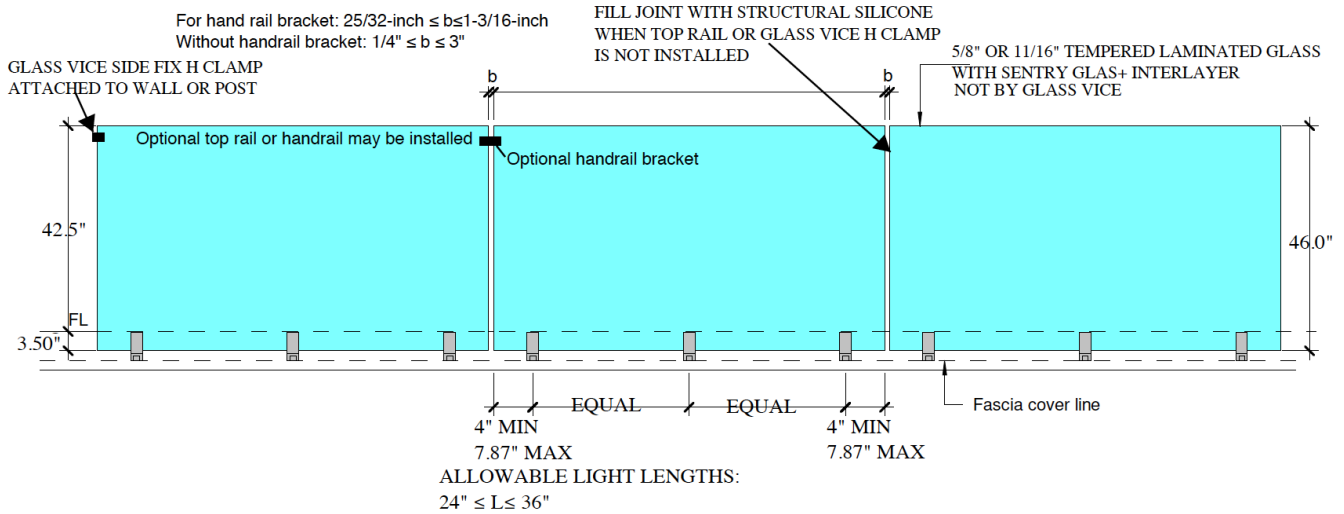

Typical installation configuration Commercial:

For 5/8 inch monolithic tempered, 5/8 inch (interior only) or 11/16 inch tempered laminated glass with Sentry Glas+ interlayer

All applications where the 50 plf live load applies: 24 inches ≤ L ≤ 40 inches and H ≤ per [Table 2](#)

Three clamps per light are always required to support the 50 plf top rail live load.

Bracket standoff distance: The typical installation is to install the bracket at 1 3/16 inches standoff from the fascia face. This may be increased to 3 inches maximum. Standoff distance may be reduced to a minimum of 9/16 inch

Fascia Cladding: The cladding is non-structural and is optional. Omission of the cladding doesn't impact any other aspects of the system installation or performance.

FIGURE 7—TYPICAL INSTALLATION CONFIGURATION COMMERCIAL - 50 PLF LIVE LOAD

POOL-SPA ENCLOSURE/WINDSCREEN

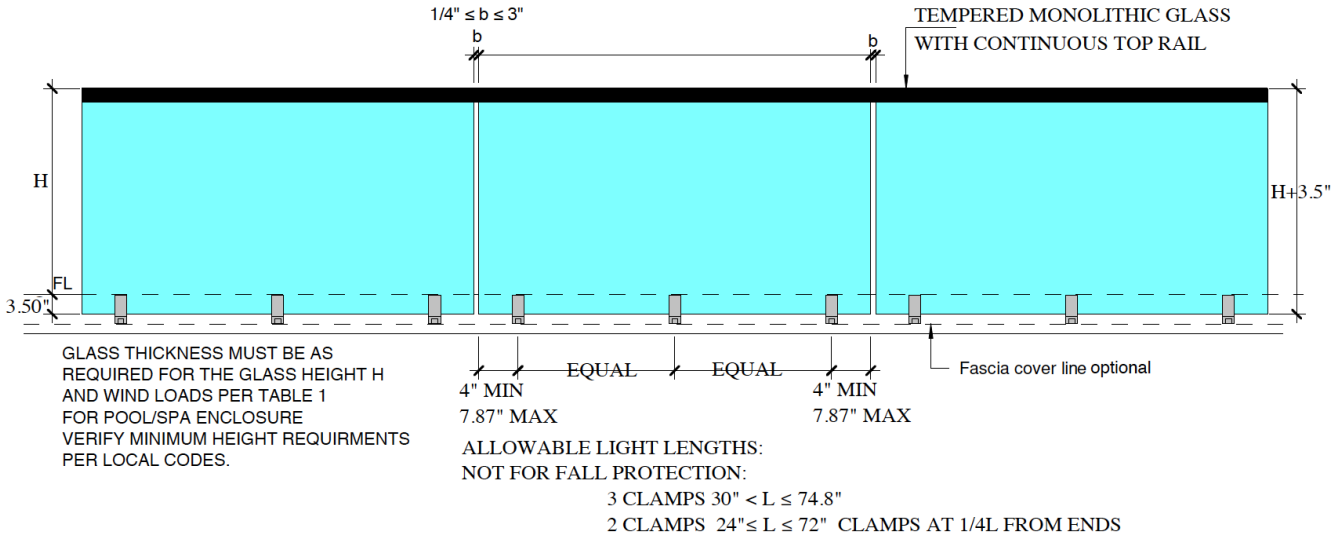

POOL-SPA ENCLOSURE/WINDSCREEN

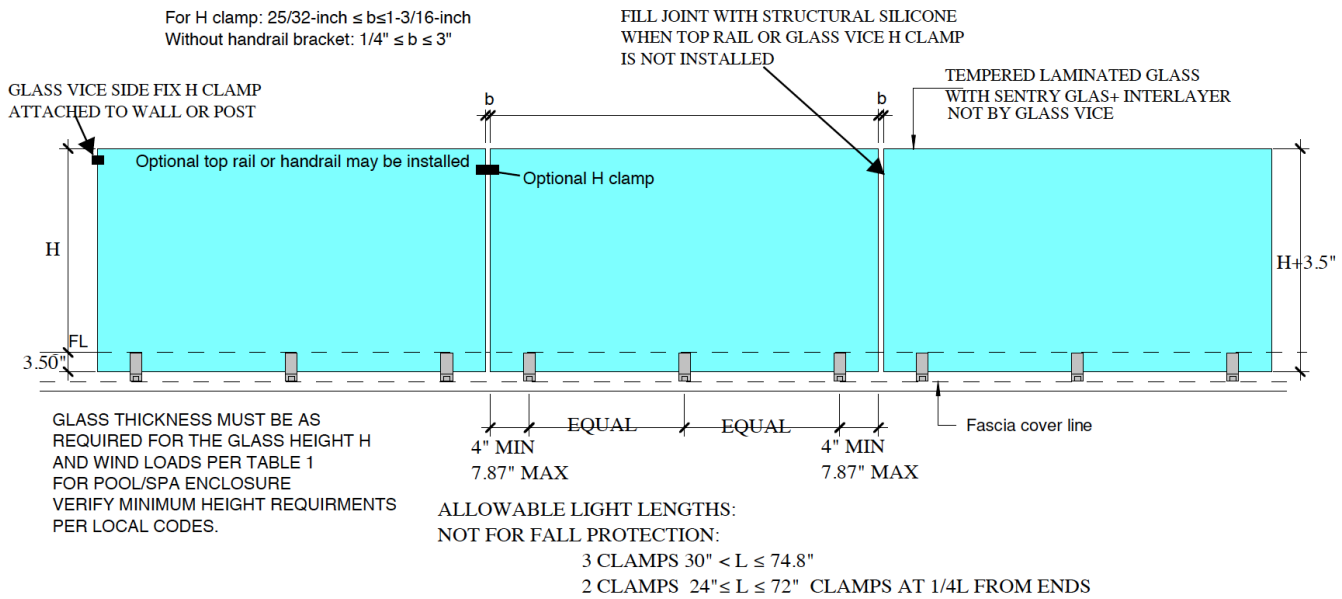

For installations where fall protection isn't required:

Bracket standoff distance: The typical installation is to install the bracket at 1 3/16 inches standoff from the fascia face. This may be increased to 3 inches maximum. Standoff distance may be reduced to a minimum of 9/16 inch.

Fascia Cladding: The cladding is non-structural and is optional. Omission of the cladding doesn't impact any other aspects of the system installation or performance.

FIGURE 8—TYPICAL INSTALLATION CONFIGURATION FOR POOL-SPA BARRIER, DIVIDER OR WINDSCREEN

DIVISION: 05 00 00—METALS

Section: 05 52 00—Metal Railings

Section: 05 73 13—Glazed Decorative Metal Railings

DIVISION: 08 00 00—OPENINGS

Section: 08 81 00—Glass Glazing

Section: 08 88 00—Special Function Glazing

REPORT HOLDER:

GLASS VICE USA LLC

EVALUATION SUBJECT:

GLASS VICE CLEARLINE® GLASS PANEL RAILING AND GLASS BALUSTER SYSTEMS

1.0 REPORT PURPOSE AND SCOPE**Purpose:**

The purpose of this evaluation report supplement is to indicate that Glass Vice Clearline® Glass Panel Railing and Glass Baluster Systems, described in ICC-ES evaluation report [ESR-4639](#), have also been evaluated for compliance with the codes noted below as adopted by the Los Angeles Department of Building and Safety (LADBS).

Applicable code editions:

- 2020 *City of Los Angeles Building Code* (LABC)
- 2020 *City of Los Angeles Residential Code* (LARC)

2.0 CONCLUSIONS

The Glass Vice Clearline® Glass Panel Railing and Glass Baluster Systems described in Sections 2.0 through 7.0 of the evaluation report [ESR-4639](#), comply with the LABC Chapter 24, and the LARC, and are subject to the conditions of use described in this supplement.

3.0 CONDITIONS OF USE

The Glass Vice Clearline® Glass Panel Railing and Glass Baluster Systems described in this evaluation report supplement must comply with all of the following conditions:

- All applicable sections in the evaluation report [ESR-4639](#).
- The design, installation, conditions of use and identification of the Glass Vice Clearline® Glass Panel Railing and Glass Baluster Systems are in accordance with the 2018 *International Building Code*® (IBC) provisions noted in the evaluation report [ESR-4639](#).
- The design, installation and inspection are in accordance with additional requirements of LABC Chapters 16 and 17, as applicable.
- Under the LARC, an engineered design in accordance with LARC Section R301.1.3 must be submitted.

This supplement expires concurrently with the evaluation report, reissued February 2024.