

# ICC-ES Evaluation Report

**ESR-4193**

Reissued February 2024

This report also contains:

- LABC Supplement
- CBC Supplement
- FBC Supplement

Subject to renewal February 2025

ICC-ES Evaluation Reports are not to be construed as representing aesthetics or any other attributes not specifically addressed, nor are they to be construed as an endorsement of the subject of the report or a recommendation for its use. There is no warranty by ICC Evaluation Service, LLC, express or implied, as to any finding or other matter in this report, or as to any product covered by the report.

Copyright © 2024 ICC Evaluation Service, LLC. All rights reserved.

<p><b>DIVISION: 31 00 00— EARTHWORK</b></p> <p><b>Section: 31 63 00— Bored Piles</b></p>	<p><b>REPORT HOLDER:</b></p> <p><b>2000 HELICAL DESIGN AND MANUFACTURING, LLC</b></p>	<p><b>EVALUATION SUBJECT:</b></p> <p><b>2000 HELICAL DESIGN AND MANUFACTURING HELICAL FOUNDATION SYSTEM</b></p>	
--	---	---	---

## 1.0 EVALUATION SCOPE

**Compliance with the following codes:**

- 2018, 2015, 2012, 2009 and 2006 [International Building Code® \(IBC\)](#)
- 2018, 2015, 2012, 2009 and 2006 [International Residential Code \(IRC\)](#)

**Properties evaluated:**

Structural and geotechnical

For evaluation for compliance with codes adopted by the [Los Angeles Department of Building and Safety \(LADBS\)](#), see [ESR-4193 LABC and LARC Supplement](#).

## 2.0 USES

The 2000 Helical Design and Manufacturing Helical Foundation System is used either to underpin foundations of existing structures or to form deep foundations for new structures, and is designed to transfer compression, tension, and lateral loads from the supported structure to suitable soil bearing strata. Underpinning of existing foundations is generally achieved by attaching the helical piles to the repair brackets (Type A side-load brackets), which support compression loads. Deep foundations for new construction are generally obtained by attaching the helical piles to new construction brackets (Type B direct-load brackets) that are embedded in concrete pile caps, footings, or grade beams, which support compression, tension and lateral loads.

When helical piles are installed under the IRC, an engineered design is required in accordance with IRC Section R301.1.3.

## 3.0 DESCRIPTION

**3.1 General:**

The 2000 Helical Design and Manufacturing Helical Foundation System consist of a helical pile and a bracket that allows for attachment to support structures. Each helical pile, consisting of a lead shaft and one or more extension shafts, as needed to reach depth, is screwed into the ground to a desired depth and suitable soil-bearing strata by applying torsion and crowd. The bracket is then installed to connect the helical pile to the concrete foundation of the supported structure.

**3.2 System Components:**

The 2000 Helical Design and Manufacturing Helical Foundation System include a 2<sup>7</sup>/<sub>8</sub>-inch-outside-diameter (73 mm) steel pipe lead shaft, extension shaft(s), and either a repair bracket or a new construction bracket for

attachment to concrete foundations. A lead shaft is connected to extension shaft(s) by couplings, as described in Section 3.2.3. The helical pile is connected to a foundation bracket, as described in Section 3.2.4.

**3.2.1 Helical Pile Lead Shafts, Extensions, and Flighted Extensions:** The helical pile lead shafts and extension shafts are available in 2<sup>7</sup>/<sub>8</sub>-inch-outside-diameter (73 mm) steel pipe having a nominal wall thickness of 0.217-inch (5.5 mm). The helical pile lead shafts consist of one or more helical-shaped circular steel plates, factory-welded to the steel shaft. The depth of the helical piles in soil is typically extended by adding one or more extension shafts that are mechanically connected together by couplers to form one continuous steel pile.

The helical lead shaft and extension shaft sections come in 3, 5 and 7 foot lengths (0.9, 1.5 and 2.1 m). See [Figure 1](#).

**3.2.2 Helix Plates:** The helical plates, which are factory-welded to the lead shafts, allow advancement into the soil as the pile is rotated. Each circular, helical, steel bearing plate (helix) is split from the center to the outside edge with spiral edge geometry. Each helix is press-formed or pulled to a clockwise downward spiral with all radial sections normal to the shaft's central longitudinal axis and with a 3-inch (76 mm) nominal pitch. The pitch is the distance between the leading and trailing edges.

The helix plates are 3/<sub>8</sub>-inch (9.5 mm) thick and have an outer diameter of 8, 10, 12, or 14 inches (203, 254, 305, or 356 mm).

The lead helix is located near the tip (bottom end) of the lead shaft. For multiple helices installation, the helical bearing plates are spaced three times the diameter of the preceding helix plate apart, starting at the tip (bottom) of the lead shaft. Typically, the smallest diameter helical bearing plate is placed near the tip (bottom) of the lead shaft and the largest diameter helical bearing plate is placed near the top (trailing end) of the lead shaft.

**3.2.3 Shaft Coupler:** The helical pile lead shafts and extension shafts are connected together by couplers, so as to allow the multiple shafts to be connected during installation. Connection of the extension shaft to the lead shaft or other extension shafts is made by through-bolted connection, through the extension shaft coupler segment and the connected lead shaft or other extension shafts.

At one end of each 2<sup>7</sup>/<sub>8</sub>-inch-outside-diameter (73 mm) extension shaft is a steel coupler that consists of a pipe sleeve, factory-welded to the end of the extension shaft, which allows the upper end to the lead shaft or the other end of extension shaft to be tight-fitted into the welded coupler. The 2<sup>7</sup>/<sub>8</sub>-inch-outside-diameter (73 mm) extension shaft coupler sleeve is a 3.5-inch-outside-diameter (89 mm) steel pipe, having a 0.254-inch (6.5 mm) nominal wall thickness. Two 0.875-inch-diameter (22.2 mm) holes are factory drilled at each end of the extension shaft and at the upper end of the lead shaft, so as to allow multiple shafts to be through-bolted together during installation. Each coupling connection includes two 3/<sub>4</sub>-inch-diameter-10 TPI GRADE 8 (19 mm) standard hex-head structural bolts and two matching hex nuts complying with Section 3.3.6.

**3.2.4 Foundation Attachments (Brackets):** The repair bracket or side load bracket is used for transferring axial compressive loads from the existing foundations to the helical piles. The new construction bracket is a Type B direct-load bracket which is used in new construction to transfer axial compression, axial tension, or lateral loads from the foundations to the helical piles. The different brackets are described in Sections 3.2.4.1 and 3.2.4.2.

#### 3.2.4.1 Repair Bracket:

The repair is comprised of three components: bracket seat, sleeve, and lifting tool. The bracket seat consists of a 3/<sub>4</sub>-inch-thick (19 mm) 90 degree back plate with 3/<sub>8</sub>-inch-thick (9.5 mm) gusset plates. The back plate and gusset plates are factory welded together to form the bracket seat. The bracket seat is then factory welded to a 3.5-inch-diameter (89 mm) steel pipe sleeve having a nominal wall thickness of 0.226-inch (5.74 mm) forming the bracket main body. A lifting tool consists of 3/<sub>4</sub>-inch-thick (19 mm) steel base plate, two (2) 3/<sub>4</sub>-inch-thick (19 mm) steel lifting plates, factory-welded together, and ACME 1-inch-diameter-5 TPI (25.4 mm) steel threaded rods with matching nuts. The lifting tool is connected to the bracket main body with two ACME 1-inch-diameter (25.4 mm)-5 TPI steel threaded rods and matching steel nuts. See [Figure 2](#).

#### 3.2.4.2 New Construction Bracket:

The new construction bracket is composed of a 6-by-6-by-3/<sub>4</sub>-inch-thick (152 by 152 by 19 mm) steel plate factory-welded to a round 3<sup>1</sup>/<sub>2</sub>-inch-outside-diameter (89 mm) steel sleeve, having a 0.254-inch (6.5 mm) nominal wall thickness with two factory-drilled through holes measuring 0.875-inch (22.2 mm). The bracket is attached to the shaft in the field with two 4-inch long-by-3/<sub>4</sub>-inch (102 by 19 mm) GRADE 8 finish ASTM F194M hex bolts with matching hex nuts. See [Figure 3](#).

### 3.3 Material Specifications:

**3.3.1 Helical Pile Lead Shafts and Extensions:** The 2<sup>7</sup>/<sub>8</sub>-inch-outside-diameter (73 mm) lead shafts and extensions are carbon steel pipes that conform to API 5 CT L80 having a minimum yield strength of 80,000 psi (552 MPa) and a minimum tensile strength of 95,000 psi (655 MPa). The lead shafts and extensions can either be bare steel or hot-dipped galvanized in accordance with ASTM A123.

**3.3.2 Helical Plates:** The helical plates are carbon steel plates conforming to ASTM A572, Grade 50, and have a minimum yield strength of 68,000 psi (469 MPa) and a minimum tensile strength of 84,000 psi (579 MPa). The helical plates are factory-welded to the shafts and can either be bare steel or hot-dipped galvanized in accordance with ASTM A123.

**3.3.3 Shaft Couplers:** The shaft couplers are carbon steel pipes that conform to API 5 CT L80 having a minimum yield strength of 80,000 psi (552 MPa) and a minimum tensile strength of 95,000 psi (655 MPa). The extension shaft couplers are factory-welded to the extensions. The extension shaft couplers can either be bare steel or hot-dipped galvanized in accordance with ASTM A123.

**3.3.4 Repair Bracket:** The plates used to fabricate the repair bracket seat and plate of the lifting tool conform to ASTM A36 having a minimum yield strength of 36,000 psi (248 MPa) and tensile strength of 58,000 psi (400 MPa). The gusset plates conform to ASTM A572, Grade 50, except for having a minimum yield strength of 68,000 psi (469 MPa) and a minimum tensile strength of 84,000 psi (579 MPa). The sleeve of the bracket seat is a steel pipe which conform to ASTM A500 Grade B, except for having a minimum yield strength of 60,800 psi (419 MPa) and a minimum tensile strength of 68,000 psi (469 MPa). The repair brackets can either be bare steel or hot-dipped galvanized in accordance with ASTM A123.

**3.3.5 New Construction Bracket:** The steel bearing plates for the new construction bracket conform to ASTM A36 having a minimum yield strength of 36,000 psi (248 MPa) and tensile strength of 58,000 psi (400 MPa). The steel pipe sleeve conforms to API 5 CT L80 having a minimum yield strength of 80,000 psi (552 MPa) and a minimum tensile strength of 95,000 psi (655 MPa). The new construction brackets can either be bare steel or hot-dipped galvanized in accordance with ASTM A123.

**3.3.6 All Other Fastening Assemblies (Including Brackets):** The threaded rods conform to ASTM A307 Grade A. The hex nuts conform to ASTM A563 Grade A. Through-bolts used to connect the new construction bracket, shaft extensions and lead shafts couplers conform to SAE J429 Grade 8 with matching hex nuts conforming to SAE J995 Grade 8. Bolts, nuts, and threaded rods can either be bare, or hot-dipped galvanized in accordance with ASTM A153.

## 4.0 DESIGN AND INSTALLATION

### 4.1 Design:

**4.1.1 General:** Engineering calculations and drawings, prepared by a registered design professional, must be submitted to the code official for each project, must be based on accepted engineering principles as described in IBC Section 1604.4, and must conform to 2018, 2015, 2012 and 2009 IBC Section 1810 (2006 IBC Section 1808). The load capacities shown in this report are based on allowable stress design (ASD) described in IBC Section 1602 and AISC 360 Section B3.4. The engineering analysis must address helical foundation system performance related to structural and geotechnical requirements.

The calculations must address the ability (considering strength and stiffness) of the supported foundation and structure to transmit the applied loads to the helical foundation system, and the ability of the helical piles and surrounding soils to support the loads applied by the supported foundation and structure. The structural analysis must consider all applicable internal forces (axial, shear, bending moments, and torsional moments, if applicable) due to applied loads, load transfer between the bracket and the pile segments (leads and extensions), and maximum span(s) between helical foundations. The result of the analysis and the structural capacities must be used to select a helical foundation system. The minimum embedment depth for various loading conditions must be included, based on the most stringent requirements of the following: engineering analysis; tested conditions described in this report; a site-specific geotechnical investigation report; and site-specific load tests, if applicable.

The geotechnical analysis must address the suitability of the helical foundation system for the specific project. It must also address the center-to-center spacing of the helical pile, considering both effects on the supported foundation and structure, and group effects on the pile-soil capacity. The analysis must include estimates of the axial tension and/or compression capacities of the helical piles, whatever is relevant for the project, and the expected total and differential foundation movements due to a single pile or pile group, as applicable.

A soil investigation report (geotechnical report) must be submitted to the code official as part of the required submittal documents, prescribed in 2018, 2015, 2012, and 2009 IBC Section 107 (2006 IBC Section 106), at the time of permit application. The geotechnical report must include, but is not limited to, all the following:

1. A plot showing the location of the soil investigation.
2. A complete record of the soil boring and penetration test logs and soil samples.
3. A record of soil profile.
4. Information on groundwater table, frost depth, and corrosion-related parameters, as described in Section 5.5 of this report.

5. Soil design parameters, such as: shear strength, soil allowable bearing pressure, unit weight of soil, soil deformation characteristics, and other parameters affecting pile support conditions as defined in 2018, 2015, 2012 and 2009 IBC Section 1810.2.1 (2006 IBC Section 1808.2.9).
6. Confirmation of the suitability of helical foundation systems for the specific project.
7. Recommendations for design criteria, including, but not be limited to: mitigation of effects of differential settlement, varying soil strength, and effects of adjacent loads.
8. Recommended center-to-center spacing of helical pile foundations, if different from spacing noted in Section 5.14 of this report; and reduction of allowable loads due to the group action, if necessary.
9. Field inspection and reporting procedures to include procedures for verification of the installed bearing capacity, when required.
10. Load test requirements.
11. Any questionable soil characteristics and special design provisions, as necessary.
12. Expected total and differential settlement.
13. The axial compression, axial tension, and lateral load soil capacities, if values cannot be determined from this evaluation report.

The allowable axial compressive or tensile load of the helical pile system must be based on the least of the following in accordance with 2018, 2015, 2012 and 2009 IBC Section 1810.3.3.1.9:

- P1: Allowable axial capacity of the bracket. Section 4.1.2 of this report includes bracket capacities.
- P2: Allowable axial capacity of pile shaft. Section 4.1.3 of this report includes pile shaft capacities.
- P3: Sum of the allowable axial capacity of helical bearing plates affixed to pile. Section 4.1.4 of this report includes helical plate axial capacities.
- P4: Allowable capacity determined from well-documented correlations with installation torque. Section 4.1.5 of this report includes torque correlation factors used to establish pile axial load capacities based on documented correlations.
- P4: Sum of the areas of the helical bearing plates times the ultimate bearing capacity of the soil or rock comprising the bearing stratum divided by a safety factor of 2. This capacity will be determined by a registered design professional based on site-specific soil conditions.
- P4: Allowable capacity predicted by dividing the ultimate capacity determined from load tests by a safety factor of at least 2.0. This capacity will be determined by a registered design professional for each site-specific condition.

**4.1.2 Bracket Capacity (P1):** [Table 1](#) describes the allowable bracket capacity for new construction bracket and repair bracket. The connections of the building structure to the helical pile brackets must be designed and included in the construction documents. The concrete foundation must be designed and justified to the satisfaction of the code official with due consideration to the eccentricity of applied loads, including reactions provided by the brackets, acting on the concrete foundation. Only localized limit states of steel and supporting concrete foundation, including punching shear and bearing, have been considered in this evaluation report. Other limit states are outside the scope of this evaluation report and must be determined by the registered design professional. The effects of reduced lateral sliding resistance due to uplift from wind or seismic loads must be considered for each project.

**4.1.3 Pile Shaft Capacity (P2):** [Table 3](#) describes the shaft allowable capacity. [Table 2](#) describes the mechanical properties of the shafts, which are based on a 50-year corrosion effect in accordance with Section 3.9 of AC308. The top of the shafts must be braced as described in 2018, 2015, 2012 and 2009 IBC Section 1810.2.2, and 2006 IBC Section 1808.2.5. In accordance with 2015, 2012 and 2009 IBC Section 1810.2.1, and 2006 IBC Section 1808.2.9, any soil other than fluid soil must be deemed to afford sufficient lateral support to prevent buckling of the systems that are braced, and the unbraced length is defined as the length of piles standing in air, water, or in fluid soils plus an additional 5 feet (1524 mm) when embedment is into firm soil, or an additional 10 feet (3048 mm) when embedment is into soft soil. Firm soils must be defined as any soil with a Standard Penetration Test (SPT) blow count of five or greater. Soft soils must be defined as any soil with a SPT blow count greater than zero and less than five. Fluid soils must be defined as any soil with a SPT blow count of zero [weight of hammer (WHO) or weight of rods (WOR)]. Standard Penetration Test blow count must be determined in accordance with ASTM D1586. The shaft capacity of the helical foundation systems in air, water or fluid soils must be determined by a registered design professional using parameters in [Table 2](#) with due consideration of lateral support provided by the surrounding soil and/or structure.

The elastic shortening/lengthening of the pile shaft will be controlled by the strength and section properties of the shaft sections and coupler(s). For loads up to and include the allowable load limits found in this report, the elastic shortening/lengthening of a shaft can be estimated as:

$$\Delta_{\text{shaft}} = P L / (A E)$$

where:

$\Delta_{\text{shaft}}$  = Length change of shaft resulting from elastic shortening/lengthening, in (mm).

P = Applied axial load, kip (kN).

L = Effective length of the shaft, in. (mm).

A = Cross-sectional area of the shaft, see [Table 2](#), in.<sup>2</sup> (mm<sup>2</sup>).

E = Young's modulus of the shaft, see [Table 2](#), ksi (MPa).

The slip of the helical pile coupler is 0.197-inch/coupler (5 mm/coupler) at rated allowable compression/tensile load per coupling.

**4.1.4 Helix Plate Capacity (P3):** [Table 4](#) describes the allowable helical bearing plate capacity. For helical piles with more than one helix, the allowable helix capacity for the helical foundation systems supporting axial compression and tension loads may be taken as the sum of the least allowable capacity of each individual helix. The helical plates are spaced three times the diameter of the preceding helical plate.

**4.1.5 Soil Capacity (P4):** [Table 5](#) describes the geotechnical related properties of the piles. The allowable axial compressive or tensile soils capacity of helical piles (P4) must be determined by a registered design professional in accordance with a site-specific geotechnical report, as described in Section 4.1.1, combined with the individual helix bearing method (Method 1), or from field loading tests conducted under the supervision of a registered design professional (Method 2). For either Method 1 or Method 2, the predicted axial load capacities must be confirmed during the site-specific production installation, such that the axial load capacities predicted by the torque correlation method are equal to or greater than what is predicted by Method 1 or 2, described above.

The individual bearing method is determined as the sum of the individual areas of the helical bearing plates times the ultimate bearing capacity of the soil or rock comprising the bearing stratum.

The design allowable axial load must be determined by dividing the total ultimate axial load capacity predicted by either Method 1 or 2, above, divided by a safety factor of at least 2.

The torque correlation method must be used to predict the ultimate capacity ( $Q_{ult}$ ) of the pile and the minimum installation torque (Equation 1). A factor of safety of 2 must be applied to the ultimate capacity to determine the allowable soil capacity ( $Q_{all}$ ) of the pile (Equation 2).

$$Q_{ult} = K_t T \quad (\text{Equation 1})$$

$$Q_{all} = 0.5 Q_{ult} \quad (\text{Equation 2})$$

where:

$Q_{ult}$  = Ultimate axial compressive or tensile capacity (lbf or N) of helical pile, which must be limited to the maximum ultimate values noted in [Table 5](#).

$Q_{all}$  = Allowable axial compressive or tensile capacity (lbf or N) of helical pile, which must be limited to the maximum ultimate values noted in [Table 5](#).

$K_t$  = Torque correlation factors are described in [Table 5](#).

T = Final installation torque in (ft-lbf or N-m). The final installation torque is defined as the last torque reading taken during the pile installation.

The allowable lateral soil capacity is 1,719 lbf (7.65 kN) for 2<sup>7</sup>/<sub>8</sub>-inch-outside-diameter helical piles. It is based on field testing of the helical piles with a single 8-inch-diameter (203 mm) helix plate installed in a firm clay soil, having an average standard penetration test blow count of 20, at a minimum embedment of 17 feet (5.18 m). For soil conditions other than firm clay, the lateral capacity of the pile must be determined by a registered design professional.

## 4.2 Installation:

The 2000 Helical Design and Manufacturing Helical Foundation System must be installed by certified and trained installers approved by 2000 Helical Design and Manufacturing, LLC. The helical foundation system must be installed in accordance with this section (Section 4.2); 2018, 2015, 2012 and 2009 IBC Section 1810.4.11; the manufacturer's published installation instructions; and approved site-specific construction documents. In case of a conflict, the most stringent requirement governs.

**4.2.1 Helical Pile Installation:** The helical piles must be installed and located in accordance with the approved plans and specifications. The lead shaft is connected to the torque motor using the drive tool and connection pins. The lead shaft is installed vertically into the ground with a maximum allowable angle of inclination of aligned  $\pm 1$  degree from vertical. The lead shaft and added extensions are rotated into the ground to achieve the termination criteria. All sections shall be advanced into the soil in a smooth, continuous manner at a rate of rotation recommended by the manufacturer. Constant axial force (crowd) shall be applied while rotating helical piles and helical anchors into the ground. The crowd applied shall be sufficient to ensure that the helical pile advances into the ground as recommended by manufacturer. Extensions (number and length) are selected based on the approved plans as specified per the site conditions by a registered design professional. The leads and extensions must be connected by coupling bolts and nuts as described in Section 3.2.3. All coupling bolts must be snug-tightened as defined in Section J3 of AISC 360. The final installation torque must equal or exceed that specified by the torque correlation method, to support the allowable design loads of the structure. The final installation torque must not exceed the Maximum Installation Torque Rating, as described in [Table 5](#). The helical piles must be installed to the minimum depth described in the approved plans below the bottom of the supported concrete foundation. For tension application, the helical pile must be installed such that the minimum depth from the ground surface to the uppermost helix is 12D, where D is the diameter of the largest helix.

#### **4.2.2 Foundation Attachments:**

**4.2.2.1 Repair Bracket:** The repair brackets must be installed as specified in the approved plans. These brackets are installed by excavating a hole adjacent to the footing at the pile location large enough to install the helical pile and bracket. Next, excavate beneath the footing, large enough to accommodate the bracket installation, as recommended by manufacturer. Using a chipping hammer, chip away and clean any concrete irregularities at the footing face and underside so that it sits fairly flat on the bracket seat. Existing concrete footing capacity must not be altered, such as with notching of concrete or cutting of reinforcing steel, without the approval of the registered design professional and the code official. The repair bracket is installed over the pile shaft, away from the concrete footing. The top of the pile shaft shall be cut off square above the bottom of the footing. Place the bracket below the footing, rotate it 180 degrees into place, and test fitted against the foundation. Make sure that the vertical face and underside of the footing are fully bearing on the bracket set. Place non-shrink grout in any voids between the footing and bracket seat. Next, the lifting tool is placed over the pile shaft, and the lifting threaded rods are lined up, inserted through the T-pipe and bracket, and secured using the nuts provided. Coupling nuts, lifting rods, lifting plates and a lifting jack are then installed over the T-pipe to lift the footing. Any lifting of the existing structure must be verified by a registered design professional and is subjected to approval of the code official to ensure that the foundation, superstructure, and helical piles are not overstressed. The bracket can be lifted only after the non-shrink grout placed during bracket installation has cured. Begin jacking to transfer the load from the foundation to the helical anchor. Jack until the structure has been lifted to the specified elevation. Tighten the nuts on top of the T-pipe to hold the bracket in place and keep all of the structure's weight on the helical anchor. Before removing the jack, double check that all nuts are tightened and back-fill the excavation. The threaded-rod nuts must be snug-tightened as defined in Section J3 of AISC 360. The excavation must be backfilled in accordance with 2018, 2015, 2012 and 2009 IBC Section 1804 (2006 IBC Section 1803).

**4.2.2.2 New Construction Bracket:** New construction bracket must be placed over the top of the helical pile shaft. The top of pile elevation must be established and must be consistent with the specified elevation. If necessary, the top of the pile may be cut off level to the required length in accordance with the manufacturer's instructions and AISC 360 requirements so as to ensure full, direct contact (bearing) between the top of the pile shaft and the bracket. When the top of the shaft is cut, field drill new holes to facilitate installation of the new construction brackets, in accordance to the approved construction drawings. All field-cut or drilled pilings may be protected from corrosion as recommended by the registered design professional and approved by the code official. For new construction brackets installed for tension application, two  $\frac{3}{4}$ -inch-diameter (19 mm) bolts and matching nuts as described in Section 3.3.6 of this report must be installed for helical piles in tension. The bolts must be snug-tightened as defined in Section J3 of AISC 360. The embedment and edge distance of the bracket into the concrete foundation must be as described in the approved plans and as indicated in [Tables 1](#) of this report. The concrete foundation must be cast around the bracket in accordance with the approved construction documents.

#### **4.3 Special Inspection:**

Continuous special inspection in accordance with 2018, 2015 and 2012 IBC Section 1705.9 (2009 IBC Section 1704.10 and 2006 IBC Section 1704.9) must be provided for the installation of the helical piles and foundation brackets. Where on-site welding is required, special inspection in accordance with 2015 and 2012 IBC Section 1705.2 (2009 and 2006 IBC Section 1704.3) is also required. Items to be recorded and confirmed by the special inspector must include, but are not necessarily limited to, the following:

1. Verification of product manufacturer and the manufacturer's certification of the installers.
2. Verification of product types and configurations for helical pile lead shafts, extensions, brackets, bolts, threaded rods, nuts, washers, and torque as specified in this report and the construction documents.
3. Installation procedures for helical pile shaft, installation equipment used, and the 2000 Helical Design and Manufacturing Helical Foundation System installation instructions.
4. Anticipated and actual piling depth.
5. Required target installation torque of piles and depth of the helical foundation system.
6. Inclination and position of helical piles; top of pile extension in full contact with bracket; tightness of all bolts; and evidence that the helical pile foundation systems are installed by an approved 2000 Industries Group installer.
7. Other pertinent installation data as required by the registered professional in responsible charge and compliance of installation with the approved geotechnical report, construction documents, and this evaluation report.

## 5.0 CONDITIONS OF USE:

The 2000 Helical Design and Manufacturing Helical Foundation System described in this report complies with, or is a suitable alternative to what is specified in, those codes indicated in Section 1.0 of this report, subject to the following conditions:

- 5.1** The helical pile system is manufactured, identified, and installed in accordance with this report, the approved construction documents, and the manufacturer's published installation instructions, which must be available at the jobsite at all times during installation. In the event of a conflict between this report, the approved construction documents and the manufacturer's published installation instructions, the most restrictive governs.
- 5.2** The helical pile system has been evaluated for support of structures assigned to Seismic Design Categories (SDCs) A, B and C in accordance with IBC Section 1613. Use of the systems to support structures assigned to SDC D, E, or F or that are located in Site Class E or F are outside the scope of this report, and are subject to the approval of the building official, based upon submission of a design in accordance with the code by a registered design professional.
- 5.3** Both the repair bracket and the new construction bracket must be used only to support structures that are laterally braced as defined in 2018, 2015, 2012 and 2009 IBC Section 1810.2.2 (2006 IBC Section 1808.2.5). Shaft couplings must be located within firm or soft soil as defined in Section 4.1.3.
- 5.4** Installation of the helical foundation systems is limited to support of uncracked normal-weight concrete, as determined in accordance with the applicable code.
- 5.5** The helical foundation systems used in soil conditions that are indicative of potential pile deterioration or corrosion situations, as defined by the following: (1) soil resistivity less than 1,000 ohm-cm; (2) soil pH less than 5.5; (3) soils with high organic content; (4) soil sulfate concentrations greater than 1,000 ppm; (5) soils located in landfill; or (6) soil containing mine waste; is beyond the scope of this report.
- 5.6** Zinc-coated steel and bare steel components must not be combined in the same system, unless they are designed as bare steel elements. All helical foundation components must be galvanically isolated from concrete reinforcing steel, building structural steel, or any other metal building components.
- 5.7** Special inspection is provided in accordance with Section 4.3 of this report.
- 5.8** The helical piles must be installed vertically into the ground with a maximum allowable angle of inclination of 1 degree from vertical. To comply with the requirements found in 2018, 2015, 2012 and 2009 IBC Section 1810.3.1.3 (2006 IBC Section 1808.2.8.8), the superstructure must be designed to resist the effects of helical pile eccentricity.
- 5.9** A soil investigation (geotechnical report) in accordance with Section 4.1.1 of this report must be submitted to the code official for approval.
- 5.10** The load combinations prescribed in Section 1605.3.2 of the IBC must be used to determine the applied loads. When using the alternative basic load combinations prescribed in Section 1605.3.2, the allowable stress increases permitted by material chapters of the IBC (Chapters 19 through 23, as applicable) or the referenced standards are prohibited.
- 5.11** Engineering calculations and drawings must be in accordance with recognized engineering principles as described in IBC Section 1604.4, in compliance with Section 4.1 of this report, prepared by a registered design professional and approved by the code official.

- 5.12 The applied loads must not exceed the allowable capacities described in Section 4.1 of this report.
- 5.13 The adequacy of the concrete structures that are connected to the brackets must be verified by a registered design professional in accordance with applicable code provisions, and is subject to the approval of the code official.
- 5.14 In order to avoid group efficiency effects, an analysis prepared by a registered design professional must be submitted where the center-to-center spacing of axially loaded helical piles is less than three times the diameter of the largest helix plate at the depth of bearing. An analysis prepared by a registered design professional must also be submitted where the center-to-center spacing of laterally loaded helical piles is less than eight times the least horizontal dimension of the pile shaft at the ground surface, and the spacing between helical plates must not be less than  $3D$ , where  $D$  is the diameter of the largest helical plate measured from the edge of the helical plate to the edge of the helical plate of the adjacent helical pile; or  $4D$ , where the spacing is measured from the center-to-center of the adjacent helical pile plates.
- 5.15 Compliance with 2018, 2015, 2012 and 2009 IBC Section 1810.3.11.1 (2006 IBC Section 1808.2.23.1.1) for buildings assigned to Seismic Design Category (SDC) C, and with 2018, 2015, 2012 and 2009 IBC Section 1810.3.6 (2006 IBC Section 1808.2.7) for all buildings, is outside the scope of this report. Such compliance must be addressed by a registered design professional for each site, and is subject to approval by the code official.
- 5.16 Settlement of the helical pile is outside the scope of this report and must be determined by a registered design professional, as required in 2018, 2015, 2012 and 2009 IBC Section 1810.2.3 (2006 IBC Section 1808.2.12).
- 5.17 The 2000 Helical Design and Manufacturing Helical Foundation Systems are manufactured at the 2000 Industries Group facility located in Carrollton, Texas, under a quality-control program with inspections by ICC-ES.

## 6.0 EVIDENCE SUBMITTED

Data in accordance with the [ICC-ES Acceptance Criteria for Helical Foundation Systems and Devices \(AC358\)](#), dated September 2017 (Editorially revised September 2018).

## 7.0 IDENTIFICATION

- 7.1 The 2000 Helical Design and Manufacturing Helical Foundation System components are identified by a tag or label bearing the name and address of 2000 Helical Design and Manufacturing, LLC, the product number, and the evaluation report number (ESR-4193).
- 7.2 The report holder's contact information is the following:

**2000 HELICAL DESIGN AND MANUFACTURING, LLC**  
**1313 WEST COLLEGE AVENUE**  
**CARROLLTON, TEXAS 75006**  
**(972) 446-8100**  
[www.2000hdm.com](http://www.2000hdm.com)



**TABLE 1—BRACKET CAPACITY (P1) FOR SIDE LOAD OR REPAIR AND NEW CONSTRUCTION BRACKET <sup>5,6</sup>**

DESCRIPTION	ALLOWABLE CAPACITY (kips)		
	Compression	Tension	Lateral
Repair Bracket	18.7 <sup>1</sup>	N/A	N/A
New Construction Bracket	42.12 <sup>2</sup>	40.24 <sup>3</sup>	1.40 <sup>4</sup>

For **SI**: 1 inch = 25.4 mm, 1 kip (1000 lbf) = 4.48 kN.

<sup>1</sup>Load capacity is based on full scale load tests per AC358 with an installed 5'-0" unbraced pile length having a maximum of one coupling per 2018, 2015, 2012 and 2009 IBC Section 1810.2.1 and 2006 IBC 1808.2.9.2. Repair brackets must be concentrically loaded and the bracket plate must be fully engaged with bottom of concrete foundation. Only localized limit states such as mechanical strength of steel components and concrete bearing have been evaluated. Minimum specified compressive strength of concrete is 2,500 psi (17.2 MPa).

<sup>2</sup>The allowable compressive load capacity is based on the mechanical strength of the steel bracket, concrete punching shear capacity and concrete bearing strength. The allowable load capacities have been determined assuming that minimum reinforcement has been provided by ACI 318-14 Section 9.6.1.2 and ACI 318-11 Section 10.5.1. The minimum embedment of the bracket is 10.5 inches. The embedment depth is the distance between the top of the bracket plate to the top of the concrete footing. End of helical pile shaft must be fully bearing on bracket plate. The concrete footing must have a minimum width of 26.9 inches, and must be normal-weight concrete having a minimum compressive strength of 3,000 psi (20.7 MPa).

<sup>3</sup>The allowable tensile load capacity is based on mechanical strength of the steel bracket, concrete punching shear capacity and concrete bearing strength. The allowable load capacities have been determined assuming that minimum reinforcement has been provided by ACI 318-14 Section 9.6.1.2 and ACI 318-11 Section 10.5.1. The minimum embedment of the bracket is 12.2 inches. The embedment depth is the distance between the bottom of the bracket plate to the bottom of the concrete footing. The capacity is based using two 3/4-inch-diameter through bolts as described in Section 3.3.6 of this report. The concrete footing must have a minimum width of 30.4 inches, and must be normal-weight concrete having a minimum compressive strength of 3,000 psi (20.7 MPa).

<sup>4</sup>The allowable lateral load capacity is based on mechanical strength of the steel bracket, concrete breakout in accordance with ACI 318 and bracket bearing on unreinforced concrete in accordance with ACI 318. The bracket must be installed with a minimum embedment depth of 3 inches measured from the bottom of the bracket plate to the bottom of the concrete footing and a minimum edge distance of 4 inches measure from the edge of the bracket plate to the concrete footing edge. The concrete footing must have a minimum width of 16 inches, and must be normal-weight concrete having a minimum compressive strength of 3,000 psi (20.7 MPa).

<sup>5</sup>The capacities listed in [Table 1](#) assume the pile foundation system is sidesway braced per 2018, 2015, 2012 and 2009 IBC Section 1810.2.2 and 2006 IBC Section 1808.2.5.

<sup>6</sup>Allowable capacities are based on bare steel losing 0.036-inch (318 μm) steel thickness as indicated in Section 3.9 of AC358 for a 50-year service life. N/A = not applicable.

**TABLE 2—MECHANICAL PROPERTIES AFTER CORROSION LOSS<sup>1</sup>**

Mechanical Properties	SHAFT DIAMETER
	2 7/8-inch (0.217-inch wall thickness)
Steel Yield Strength, F <sub>y</sub> (ksi)	80
Steel Ultimate Strength, F <sub>u</sub> (ksi)	95
Modulus of Elasticity, E (ksi)	29,000
Nominal Wall Thickness (inch)	.217
Design Wall Thickness (inch)	0.154
Outside Diameter (inch)	2.839
Inside Diameter (inch)	2.531
Cross Sectional Area (inch <sup>2</sup> )	1.30
Moment of Inertia, I (inch <sup>4</sup> )	1.17
Radius of Gyration, r (inch)	0.95
Section Modulus, S (inch <sup>3</sup> )	0.83
Plastic Section Modulus, Z (inch <sup>3</sup> )	1.11

For **SI**: 1 inch = 25.4 mm; 1 ksi = 6.89 MPa, 1 ft-lbf = 1.36 N-m; 1 lbf = 4.45 N.

<sup>1</sup>Dimensional properties are based on bare steel losing 0.036-inch steel thickness as indicated in Section 3.9 of AC358 for a 50-year service life.

**TABLE 3—SHAFT ALLOWABLE CAPACITY (P2) FOR 2<sup>7</sup>/<sub>8</sub>-INCH-DIAMETER PILE WITH COUPLER ECCENTRICITY<sup>3,4,5</sup> (kips)**

SHAFT TYPE	UNBRACED SHAFT LENGTH, L <sub>u</sub> (FT) <sup>1</sup>	(P2) ALLOWABLE CAPACITY (KIPS) FOR 2 <sup>7</sup> / <sub>8</sub> -INCH DIAMETER SHAFT					
		COMPRESSION (KIPS)			TENSION (KIPS)	LATERAL SHEAR (KIPS)	BENDING MOMENT (KIPS-FT)
		0 Coupler	1 Coupler <sup>2</sup>	2 Couplers <sup>2</sup>			
2 <sup>7</sup> / <sub>8</sub> -inch OD (0.217-inch wall thickness)	0	62.2	62.2	62.2	29.1	14.5	4.43
	5	25.5	18.5	11.1			
	10	11.5	9.8	7.2			

For SI: 1 inch = 25.4 mm; 1 ft = 0.305 m; 1 kip (1000 lbf) = 4.48 kN.

<sup>1</sup>L<sub>u</sub>=Total unbraced pile length per 2018, 2015, 2012 and 2009 IBC Section 1810.2.1 and 2006 IBC Section 1808.2.9.2, including the length in air, water or in fluid soils, and the embedment length into firm or soft soil (non-fluid soil). k = Effective length factor. kL<sub>u</sub> = total effective unbraced length of the pile, where kL<sub>u</sub> = 0 represent a fully braced condition in that the total pile length is fully embedded in firm or soft soil and the supported structure is braced in accordance 2018, 2015, 2012 and 2009 IBC Section 1810.2.2 (Section 1808.2.5 of the 2006 IBC).

<sup>2</sup>Number of couplings within L<sub>u</sub>

<sup>3</sup>The capacities shown in Table 3 are for pilings installed with a maximum 1 degree of inclination and the assumption that the pile shaft is concentrically loaded.

<sup>4</sup>Capacities based on two 3/4-inch bolts with matching nuts installed complying with Section 3.3.6. The bolt threads are excluded from the connection shear plane.

<sup>5</sup>Allowable capacities are based on bare steel losing 0.036-inch (318 μm) steel thickness as indicated in Section 3.9 of AC308 for a 50-year service life

**TABLE 4—HELICAL BEARING PLATE CAPACITY (P3) FOR 2<sup>7</sup>/<sub>8</sub>-INCH HELICAL PILES<sup>1,2,3</sup>**

HELIX DIAM. (IN)	HELIX THICKNESS (IN)	ALLOWABLE CAPACITY (P3) (KIPS)
8	3/8	42.3
10	3/8	46.7
12	3/8	42.8
14	3/8	57.1

For SI: 1 inch = 25.4 mm, 1 kip = 4.448 kN.

<sup>1</sup>For helical piles with more than one helix, the allowable helix capacity, P3, for the helical foundation systems, may be taken as the sum of the least allowable capacity of each individual helix.

<sup>2</sup>As described in Section 3.2.2 of this report, all helical bearing plates are made from same material, and have the same edge geometry, thickness and pitch.

<sup>3</sup>Allowable capacities are based on bare steel losing 0.036-inch (318 μm) steel thickness as indicated in Section 3.9 of AC308 for a 50-year service life.

TABLE 5—SOIL CAPACITY (P4) – AXIAL TENSION AND COMPRESSION FOR 2<sup>7</sup>/<sub>8</sub>-INCH HELICAL PILES<sup>1</sup>

GEOTECHNICAL RELATED PROPERTIES	2 <sup>7</sup> / <sub>8</sub> -INCH HELICAL PILE	
	Compression	Tension
Mechanical Torsion Rating (ft-lbs) <sup>3</sup>	9281	9281
Maximum Torque Per Soil Tests (ft-lbs) <sup>4</sup>	9006	9011
Maximum Installation Torque Rating (ft-lbs) <sup>5</sup>	9006	9011
Torque Correlation Factor, K <sub>t</sub> (ft <sup>-1</sup> )	9.0	9.0
Maximum Ultimate Soil Capacity / Maximum Allowable Soil Capacity (P4) from Torque Correlations (kips) <sup>2</sup>	81.1/40.5	72.2/36.1

For SI: 1 foot = 0.305 m, 1 lbf = 4.448 N, 1 lbf-ft = 1.356 N-m.

<sup>1</sup>Soil capacity (P4) must be determined per Section 4.1.5 of this report.

<sup>2</sup>Maximum ultimate soil capacity is determined from  $P_{ult} = K_t \times T$  based on the corresponding maximum installation torque rating for the specific pile model. Allowable soil capacity is determined from  $P_a = P_{ult} / 2.0$  based on the corresponding maximum installation torque rating for the specific pile model. See Section 4.1.5 for additional information.

<sup>3</sup>Mechanical torsion rating is the maximum torsional resistance of the steel shaft.

<sup>4</sup>Maximum Torque Per Soil Tests is the maximum torque achieved during field axial verification testing that was conducted to verify the pile axial capacity related to pile-soil interaction.

<sup>5</sup>Maximum Installation Torque rating is the lower of the "mechanical torsion rating" and the "maximum torque per soil tests".

<sup>6</sup>Minimum Measured Field Test Capacity is the lowest axial compression failure in field tests.

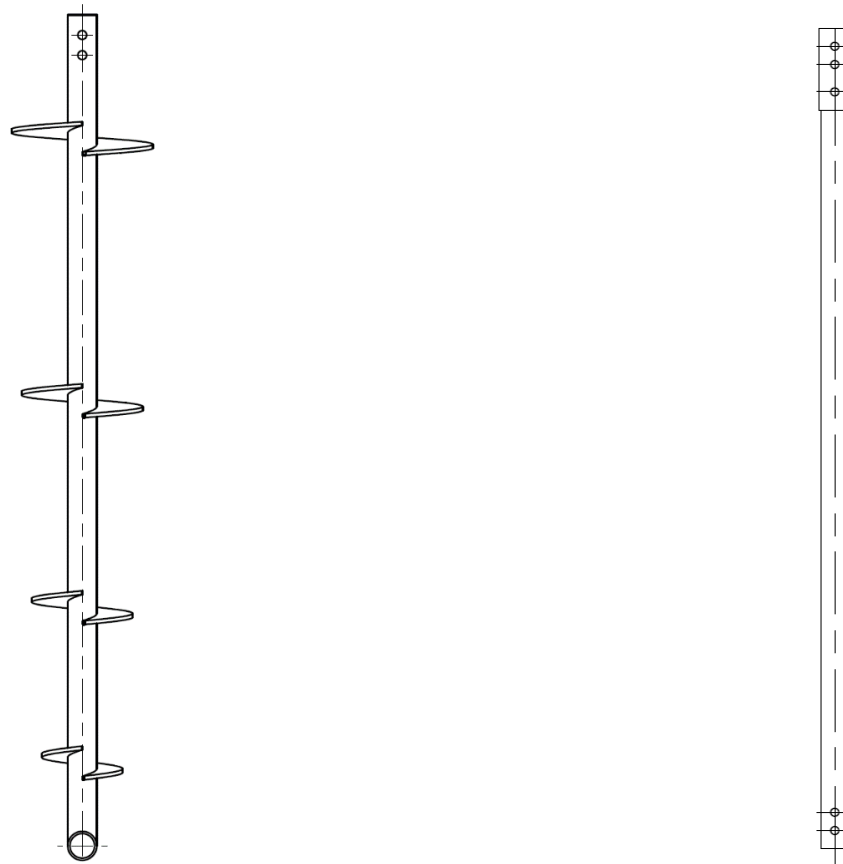

FIGURE 1—TYPICAL HELICAL PILE LEAD AND EXTENSION WITH COUPLER

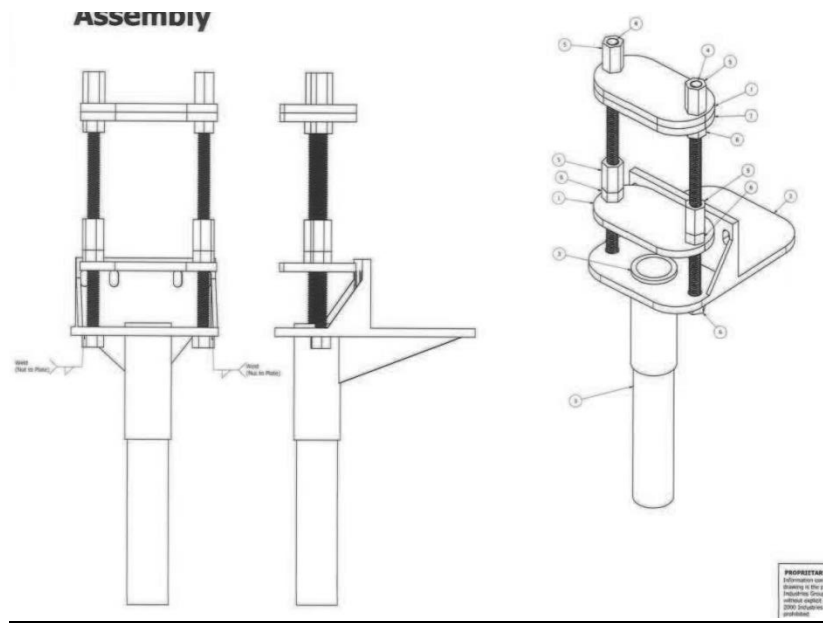

FIGURE 2—REPAIR BRACKET

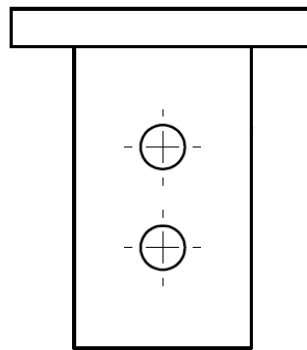

FIGURE 3—NEW CONSTRUCTION BRACKET

DIVISION: 31 00 00—EARTHWORK  
Section: 31 63 00—Bored Piles

**REPORT HOLDER:**

2000 HELICAL DESIGN AND MANUFACTURING, LLC

**EVALUATION SUBJECT:**

2000 HELICAL DESIGN AND MANUFACTURING HELICAL FOUNDATION SYSTEM

**1.0 REPORT PURPOSE AND SCOPE****Purpose:**

The purpose of this evaluation report supplement is to indicate that the 2000 Helical Design and Manufacturing Helical Foundation System, described in ICC-ES evaluation report [ESR-4193](#), has also been evaluated for compliance with the codes noted below as adopted by the Los Angeles Department of Building and Safety (LADBS).

**Applicable code editions:**

- 2017 *City of Los Angeles Building Code* (LABC)
- 2017 *City of Los Angeles Residential Code* (LARC)

**2.0 CONCLUSIONS**

The 2000 Helical Design and Manufacturing Helical Foundation System, described in Sections 2.0 through 7.0 of the evaluation report [ESR-4193](#), complies with the LABC Section 1810, and the LARC, and is subject to the conditions of use described in this supplement.

**3.0 CONDITIONS OF USE**

The 2000 Helical Design and Manufacturing Helical Foundation System described in this evaluation report must comply with all of the following conditions:

- All applicable sections in the evaluation report [ESR-4193](#).
- The design, installation, conditions of use and identification of the helical foundation system are in accordance with the 2015 *International Building Code*® (2015 IBC) provisions noted in the evaluation report [ESR-4193](#).
- The design, installation and inspection are in accordance with additional requirements of LABC Chapters 16 and 17, Sections 1803 and 1810.3.1.5, as applicable.
- The 2000 Helical Design and Manufacturing Helical Foundation System is used to underpin foundations of existing structures or retrofit or remediate deficient foundations of existing structures, and must not be used to support new structures.
- The 2000 Helical Design and Manufacturing Helical Foundation System must not be used to resist any horizontal loads.
- The 2000 Helical Design and Manufacturing Helical Foundation System that includes new construction brackets is not applicable to this supplement.
- Sections 5.2 and 5.15 of the evaluation report [ESR-4193](#) are not applicable to this supplement.
- Under the LARC, an engineered design in accordance with LARC Section R301.1.3 must be submitted.

This supplement expires concurrently with the evaluation report, reissued February 2024.

DIVISION: 31 00 00—EARTHWORK

Section: 31 63 00—Bored Piles

## REPORT HOLDER:

2000 HELICAL DESIGN AND MANUFACTURING, LLC

## EVALUATION SUBJECT:

2000 HELICAL DESIGN AND MANUFACTURING HELICAL FOUNDATION SYSTEM

## 1.0 REPORT PURPOSE AND SCOPE

## Purpose:

The purpose of this evaluation report supplement is to indicate that the 2000 Helical Design and Manufacturing Helical Foundation System, described in ICC-ES evaluation report ESR-4193, has also been evaluated for the codes noted below.

## Applicable code editions:

- 2016 *California Building Code (CBC)*
- 2016 *California Residential Code (CRC)*

For evaluation of applicable chapters adopted by the California Office of Statewide Health Planning and Development (OSHPD) AKA: California Department of Health Care Access and Information (HCAI) and the Division of the State Architect (DSA), see Sections 2.1.1 and 2.1.2 below.

## 2.0 CONCLUSIONS

**2.1 CBC:** The 2000 Helical Design and Manufacturing Helical Foundation System, described in Sections 2.0 through 7.0 of the evaluation report ESR-4193, comply with CBC Chapter 18, provided the design and installation are in accordance with the *International Building Code*® (IBC) provisions noted in the evaluation report, and the additional inspection requirements of CBC Sections 1705.9.

**2.1.1 OSHPD:** CBC applicable Section 1810.3.1.5.1, Chapters 17A and 18A are beyond the scope of this supplement.

**2.1.2 DSA:** CBC applicable Chapters 17A and 18A are beyond the scope of this supplement.

**2.2 CRC:** The 2000 Helical Design and Manufacturing Helical Foundation System, described in Sections 2.0 through 7.0 of the evaluation report ESR-4193, complies with CRC Chapter 3, provided the design and installation are in accordance with the *International Residential Code*® (IRC) provisions noted in the evaluation report.

This supplement expires concurrently with the evaluation report, reissued February 2024.

**DIVISION: 31 00 00—EARTHWORK**

**Section: 31 63 00—Bored Piles**

**REPORT HOLDER:**

**2000 HELICAL DESIGN AND MANUFACTURING, LLC**

**EVALUATION SUBJECT:**

**2000 HELICAL DESIGN AND MANUFACTURING HELICAL FOUNDATION SYSTEM**

**1.0 REPORT PURPOSE AND SCOPE**

**Purpose:**

The purpose of this evaluation report supplement is to indicate that the 2000 Helical Design and Manufacturing Helical Foundation System, described in ICC-ES evaluation report ESR-4193, has also been evaluated for compliance with the codes noted below.

**Applicable code editions:**

- 2017 *Florida Building Code—Building*
- 2017 *Florida Building Code—Residential*

**2.0 CONCLUSIONS**

The 2000 Helical Design and Manufacturing Helical Foundation System, described in Sections 2.0 through 7.0 of the evaluation report ESR-4193, comply with the *Florida Building Code—Building* and the *Florida Building Code—Residential*, provided the design and installation are in accordance with the 2015 *International Building Code*® provisions noted in the evaluation report and the following conditions apply:

Use of 2000 Helical Design and Manufacturing Helical Foundation System for compliance with the High-Velocity Hurricane Zone provisions of the *Florida Building Code—Building* and the *Florida Building Code—Residential* has not been evaluated, and is outside the scope of this supplemental report.

For products falling under Florida Rule 9N-3, verification that the report holder's quality-assurance program is audited by a quality-assurance entity approved by the Florida Building Commission for the type of inspections being conducted is the responsibility of an approved validation entity (or the code official, when the report holder does not possess an approval by the Commission).

This supplement expires concurrently with the evaluation report, reissued February 2024.