

ICC-ES Evaluation Report

ESR-3982

Reissued September 2023

This report also contains:

- CBC Supplement

Subject to renewal September 2025

ICC-ES Evaluation Reports are not to be construed as representing aesthetics or any other attributes not specifically addressed, nor are they to be construed as an endorsement of the subject of the report or a recommendation for its use. There is no warranty by ICC Evaluation Service, LLC, express or implied, as to any finding or other matter in this report, or as to any product covered by the report.

Copyright © 2023 ICC Evaluation Service, LLC. All rights reserved.

<p>DIVISION: 31 00 00 — EARTHWORK</p> <p>Section: 31 63 00 — Bored Piles</p>	<p>REPORT HOLDER: HELICAL ANCHORS, INC.</p> <p>ADDITIONAL LISTEE: BHUJ POLYMERS PRIVATE LIMITED</p>	<p>EVALUATION SUBJECT: HELICAL ANCHORS HELICAL FOUNDATION SYSTEMS</p>	
--	---	--	---

1.0 EVALUATION SCOPE

Compliance with the following codes:

2018, 2015, 2012, and 2009 [International Building Code® \(IBC\)](#)

Properties evaluated:

Structural and geotechnical

2.0 USES

The Helical Anchors helical foundation systems are used either to underpin foundations of existing structures or to form deep foundations for new structures; and are designed to transfer compression, tension, and lateral loads from the supported structure to suitable soil bearing strata. Underpinning of existing foundations is generally achieved by attaching the helical piles to the repair brackets, which support only compression loads. Deep foundations for new construction are generally obtained by attaching the helical piles to new construction brackets that are bedded in concrete pile caps, footings, or grade beams, which support compression, tension, and lateral loads.

3.0 DESCRIPTION

3.1 General:

The Helical Anchors helical foundation systems consist of a lead shaft section with one or more helical-shaped steel bearing plates (or helices), extension shaft section(s), couplings that connect multiple shaft sections, and a bracket that allows for attachment to the supported structures. The shafts with helix bearing plates are screwed into the ground by application of torsion and the shaft is extended until a desired depth or a suitable soil or bedrock bearing stratum is reached. The bracket is then installed to connect the pile to the concrete foundation of the supported structure.

3.2 System Components:

3.2.1 Helical Piles: The Helical Anchors helical pile lead shaft sections consist of one or more (up to three) helical-shaped circular steel plates factory-welded to the lead steel shaft. The extension shaft sections have shafts similar to the lead shaft sections, except without the helical plates. The depth of the helical piles in soil is typically extended by adding one or more steel shaft extensions that are mechanically connected together by couplers to form one continuous steel pile.

The shaft lead sections, and extension sections consist of a 2⁷/₈-inch-outside-diameter (73 mm) round hollow steel tubing having a nominal wall thickness of 0.217-inch (5.5 mm) minimum wall thickness.

Each helical steel bearing plate (helix) is ³/₈ inch (9.5 mm) thick and has spiral edge geometry with an outer diameter of 8, 10, 12 or 14-inches (203, 254, 305 or 356 mm). The helix plates are pressed to form a 3-inch (76.2 mm) pitch, which is the distance between the leading and trailing edges. The lead helix is located near the tip (bottom end) of the shaft lead section. For multiple helix installation, the helical bearing plates are spaced three times the diameter of the lowest plate apart starting at the toe of the lead section. Typically, the smallest diameter helical bearing plate is placed near the tip (bottom) of the lead section and the largest diameter helical bearing plate is placed nearest the top (trailing end) of the lead section or on an extension section.

The helical pile lead shaft sections and extension sections are connected together by a bolted pin-box coupling system. The coupler pin consists of a round solid steel bar ([Figure 4](#)). The coupler box consists of a 2⁷/₈-inch-outside-diameter (73 mm) round hollow steel tubing ([Figure 4](#)). Each extension section consists of a pin coupler and a box coupler which are inertia-friction welded, in the factory, to the opposing extension ends. Each lead shaft section consists of a box coupler that is inertia-friction welded, in the factory, to the top end of the lead shaft. Connection of extension sections to the lead shaft or other extension sections is made by through-bolted connections with three ³/₄-inch-diameter (19 mm) steel bolts through the extension section coupling pin and the connected lead or other extensions coupling box. [Figure 4](#) illustrates the coupling pin and box connections.

Leads and extensions may be either bare steel or hot-dipped galvanized in accordance with ASTM A123.

3.2.2 Brackets: Brackets are constructed from steel plate and steel pipe components, which are factory-welded together. The different brackets are described in Sections 3.2.2.1 and 3.2.2.2. All brackets may be either bare steel or hot-dipped galvanized in accordance with ASTM A123.

3.2.2.1 Type A Side Load Bracket: This bracket is used to support existing concrete foundations by transferring axial compressive loads from the existing foundations to the helical pile. The bracket seat is constructed of a ⁵/₁₆-inch-thick (8 mm) steel plate bent to a 90-degree angle seat measuring 14 inches (mm) wide by 7.69 inches (195 mm) long on the horizontal leg and 6.53 inches (166 mm) on the vertical leg. The bracket seat is factory-welded to other steel plates to form the bracket main body. Among the steel plates the seat is welded to, there are two steel vertical side plates that form the external guide sleeve for the bracket. See [Figure 3](#) of this report. The 2⁷/₈-inch-outside-diameter (73 mm) pile shaft is inserted through the external guide sleeve. Once the 2⁷/₈-inch-outside-diameter (73 mm) pile shaft has been installed through the external guide sleeve, the pile is cut approximately 6 inches (152 mm) above the bracket. One ⁵/₈-inch-diameter (15.8 mm) heavy hex bolt with a matching nut is installed to the steel vertical side plates to confine the 2⁷/₈-inch-outside-diameter (73 mm) pile shaft. A lifting T-pipe consists of a 1.75-in (44 mm) round corner square top bar and a 1.66-inch-outside-diameter (42 mm) round steel tubing having a nominal wall thickness of 0.313-inch (8 mm) and a length of 18 inches (457 mm). The lifting T-bracket is connected to the bracket main body with two ⁷/₈-inch-diameter steel threaded rods, four matching standard hex nuts, and matching steel washers. See [Figure 3](#) of this report. The repair brackets may be either bare steel or hot-dipped galvanized in accordance with ASTM A123.

3.2.2.2 Type B and Type B-1 Direct Load Brackets: These brackets are used with the helical pile system in new construction where the steel bearing plate of the bracket is cast into new concrete grade beams, footings, or pile caps. The brackets can transfer compression, tension and lateral loads between the pile and the concrete foundation. Refer to footnotes in [Table 1](#) for requirements of concrete cover and end/edge distance. The brackets come in two configurations. The first configuration, identified as Type B, consists of an 8-by-8-by-³/₄-inch (203 by 203 by 19 mm) thick bearing plate factory-welded to a round 3¹/₂-inch-outside-diameter (89mm) round hollow steel tubing, having a nominal wall thickness of 0.254-inch and a length of 6.5 inches (165 mm). Type B bracket is attached to the shaft in the field with three ³/₄-inch (19 mm) standard hex bolts with matching ³/₄-inch (19 mm) standard hex nuts. See [Figure 1](#) of this report. The second configuration, identified as Type B-1, consists of an 8-by-8-by-¹/₂-inch (203 by 203 by 13 mm) thick bearing plate factory-welded to a round 3¹/₂-inch-outside-diameter (89mm) round hollow steel tubing, having a nominal wall thickness of 0.254-inch and a length of 3.5 inches (89 mm). Type B-1 bracket is attached to the shaft in the field with one ³/₄-inch (19 mm) standard hex bolt with matching ³/₄-inch (19 mm) standard hex nut. See [Figure 2](#) of this report. The brackets maybe either bare steel or hot-dipped galvanized in accordance with ASTM A123.

3.3 Material Specifications:

3.3.1 Helix Plates: The $\frac{3}{8}$ -inch-thick helix plates have an outer diameter of 8, 10, 12, or 14 inches (203, 254, 305 or 356 mm) which are made from carbon steel plates conforming to ASTM A572 or similar and having a minimum yield strength of 50,000 psi (345 MPa) and a minimum tensile strength of 65,000 psi (448 MPa). The helix plates are factory-welded to the shafts and are either bare steel or hot-dipped galvanized in accordance with ASTM A123.

3.3.2 Helical Pile Lead Shafts and Extensions: The lead shafts and extensions are round hollowed steel tubes that conform to API-5CT N80 and having a minimum yield strength of 80,000 psi (551 MPa) and a minimum tensile strength of 100,000 psi (689 MPa). The lead shafts and extensions may be either bare steel or hot-dipped galvanized in accordance with ASTM A123.

3.3.3 Shaft Pin and Box Couplers: The shaft pin and box couplers are round hollowed steel tubes. The pin couplers conform to AISI C4140 or EN-19, having a minimum yield strength of 107,000 psi (738 MPa) and a minimum tensile strength of 130,000 psi (896 MPa). The box couplers conform to SAE 1527 and must have a minimum yield strength of 107,000 psi (738 MPa) and a minimum tensile strength of 130,000 psi (896 MPa). The shaft pin and box couplers are inertia-friction welded, in the factory, to shaft leads and extensions. The couplers may be either bare steel or hot-dipped galvanized in accordance with ASTM A123.

3.3.4 Type A Side Load Bracket: The plates used to fabricate Type A bracket main body conform to ASTM A36 or similar, having a minimum yield strength of 36,000 psi (248 MPa) and a minimum tensile strength of 58,000 psi (400 MPa). The round corner square top bar which is part of the lifting T-pipe is made from steel conforming to ASTM A500 Gr. B, except for having a minimum yield strength of 46,000 psi (317 MPa) and a minimum tensile strength of 58,000 psi (400 MPa). The round steel tubing which is a part of the lifting T-pipe is made from steel conforming to ASTM A500 Grade B, having a minimum yield strength of 46,000 psi (317 MPa) and a minimum tensile strength of 58,000 psi (400 MPa). The steel bolts and full threaded rods conform to either ASTM A325 or SAE J429 Grade 5, having a minimum tensile strength of 120,000 psi (827 MPa). SAE J995 Grade 5 nuts and ASTM F436 washers are used to fasten the treaded rods to the bracket. Type A bracket may be either bare steel or hot-dipped galvanized in accordance with ASTM A123.

3.3.5 Type B and Type B-1 Direct Load Brackets: The steel bearing plate conforms to ASTM A36, having a minimum yield strength of 36,000 psi (248 MPa) and a minimum tensile strength of 58,000 psi (400 MPa). The round hollowed steel tubing conforms to API-5CT N80 and having a minimum yield strength of 80,000 psi (551 MPa) and a minimum tensile strength of 100,000 psi (689 MPa). When required, the bolts connecting the Type B and Type B-1 brackets to the shaft or extension must comply with Section 3.3.6 of this report. Type B and Type B-1 brackets are made from either bare steel or hot-dipped galvanized in accordance with ASTM A123.

3.3.6 All Other Fastening Assemblies (Including Brackets): The bolts, used to connect the lead and extension sections, or connect shaft to Type B or Type B-1 brackets, conform to ASTM A325 or SAE J429 Grade 5, having a tensile strength of 120,000 psi (827 MPa). The matching hex nuts conform to ASTM A563 Grade C (or SAE J995 Gr. 2 for the coupler's nuts). Bolts and nuts can either be bare steel or hot-dipped galvanized in accordance with ASTM A153.

4.0 DESIGN AND INSTALLATION

4.1 Design:

4.1.1 General: Engineering calculations (analysis and design) and drawings, prepared by a registered design professional, must be submitted to and be subjected to the approval of the code official for each project, and must be based on accepted engineering principles, as described in IBC Section 1604.4, and must conform to IBC Section 1810. The design method for the steel components is Allowable Strength Design (ASD), described in IBC Section 1602 and AISC 360 Section B3.4. The engineering analysis must address helical foundation system performance related to structural and geotechnical requirements.

The structural analysis must consider all applicable internal forces (tension, compression, shears, bending moments and torsional moments, if applicable) due to applied loads, structural eccentricity, and maximum span(s) between helical foundations. The result of this analysis and the structural capacities must be used to select a helical foundation system.

The Helical Anchors direct load brackets (Type B and Type B-1 brackets) exert a force on the footing or grade beam in which they are embedded. The force is equal in magnitude and opposite in direction to the force in the pile. A small lateral force is developed at the bracket embedment if the pile shaft is not perfectly plumb

but within the permitted inclination from vertical of $\pm 1^\circ$. The lateral shear is equal to $\sin(1^\circ)$ or $0.0175 \times$ the axial force exerted on the pile by the foundation.

The minimum embedment depth of piles for various loading conditions must be included based on the most stringent requirements of the following: engineering analysis, tested conditions described in this report, the site-specific geotechnical investigation report, and site specific load tests, if applicable.

The allowable strengths (allowable capacities) of the steel components of the Helical Anchors helical foundation systems are described in [Table 1](#) (for brackets, P1); [Table 2\(a\)](#) (for shafts, P2); and [Table 3](#) (for helical bearing plates, P3). The soil capacities, or capacities related to pile-soil interactions, (P4), are described in Section 4.1.5 and [Table 4](#).

The overall capacity of the Helical Anchors helical foundation systems depends upon the analysis of interaction of shafts, helical plates, and soils, and must be based on the least of the following conditions (P1, P2, P3 and P4), in accordance with IBC Section 1810.3.3.1.9:

- P4: Allowable load predicted by the individual helix bearing method (or Method 1) described in Section 4.1.5 of this report.
- P4: Allowable load predicted by the torque correlation method described in Section 4.1.5 of this report.
- P4: Allowable load predicted by dividing the ultimate capacity determined from load tests (Method 2 described in Section 4.1.5) by a safety factor of at least 2.0. This allowable load will be determined by a registered design professional for each site-specific condition.
- P3: Sum of the allowable axial capacity of helical bearing plates affixed to the pile shaft. See Section 4.1.4 of this report.
- P1: Allowable axial load capacity of the bracket. See Section 4.1.2 of this report.

A written report of the geotechnical investigation must be submitted to the code official as part of the required submittal documents, prescribed in IBC Section 107, at the time of the permit application. The geotechnical report must include, but not be limited to, all of the following information:

- A plot showing the location of the soil investigation.
- A complete record of the soil boring and penetration test logs and soil samples.
- A record of soil profile.
- Information on ground-water table, frost depth and corrosion related parameters, as described in Section 5.5 of this report.
- Soil properties, including those affecting the design such as support conditions of the piles.
- Soil design parameters, such as shear strength parameters as required by Section 4.1.5; soil deformation parameters; and relative pile support conditions as defined in IBC Section 1810.2.1.
- Confirmation of the suitability of Helical Anchors helical foundation systems for the specific project.
- Recommendations for design criteria, including but not be limited to: mitigations of effects of differential settlement and varying soil strength; and effects of adjacent loads.
- Recommended center-to-center spacing of helical pile foundations, if different from Section 5.14 of this report; and reduction of allowable loads due to the group action, if necessary.
- Field inspection and reporting procedures (to include procedures for verification of the installed bearing capacity when required).
- Load test requirements.
- Any questionable soil characteristics and special design provisions, as necessary.
- Expected total and differential settlement.
- The axial compression, axial tension and lateral load soil capacities for allowable capacities that cannot be determined from this evaluation report.
- Minimum helical pile depth, if any, based on local geologic hazards such as frost, expansive soils, or other condition.

4.1.2 Bracket Capacity (P1): [Table 1](#) describes the allowable bracket capacity for Type A (Side Load) Brackets, and Type B and Type B-1 (Direct Load) Brackets. The connections of the building structure to the helical pile brackets must be designed and included in the construction documents. Only localized limit states of supporting concrete including 2-way punching shear and concrete bearing have been evaluated in this

evaluation report. The concrete foundation must be designed and justified to the satisfaction of the code official with due consideration to the eccentricity of applied loads, including reactions provided by the brackets, acting on the concrete foundation. Refer to item 5.3 of this report for bracing requirement.

4.1.3 Shaft Capacity (P2): [Table 2\(a\)](#) describes the allowable axial compression, axial tension, lateral shear, and bending moment loads of the shaft. [Table 2\(b\)](#) describes the mechanical properties of the shaft which are based on a 50-year corrosion effect in accordance with Section 3.9 of AC358. The top of shafts must be braced as prescribed in IBC Section 1810.2.2, and the supported foundation structures such as concrete footings are assumed to be adequately braced such that the supported foundation structures provide lateral stability for the pile systems. In accordance with IBC Section 1810.2.1, any soil other than fluid soil must be deemed to afford sufficient lateral support to prevent buckling of the systems that are braced, and the unbraced length is defined as the length of piles that is standing in air, water or in fluid soils plus additional 5 feet (1524 mm) when embedded into firm soil or additional 10 feet (3048 mm) when embedded into soft soil. Firm soils shall be defined as any soil with a Standard Penetration Test blow count of five or greater. Soft soil shall be defined as any soil with a Standard Penetration Test blow count greater than zero and less than five. Fluid soils shall be defined as any soil with a Standard Penetration Test blow count of zero [weight of hammer (WOH) or weight of rods (WOR)]. Standard Penetration Test blow count shall be determined in accordance with ASTM D1586. The shaft capacity of helical foundation systems in air, water, and fluid soils must be determined by a registered design professional.

The elastic shortening of the pile shaft will be controlled by the strength and section properties of the shaft sections and coupler(s). For loads up to and include the allowable load limits found in this report, the elastic shortening of shaft can be estimated as: $\Delta_{\text{shaft}} = P L / (A E)$

where:

Δ_{shaft} = Length change of shaft resulting from elastic shortening, in (mm).

P = applied axial load, lbf (N).

L = effective length of the shaft, in. (mm).

A = cross-sectional area of the shaft, see [Table 2\(b\)](#), in.² (mm²).

E = Young's modulus of the shaft, see [Table 2\(b\)](#), ksi (MPa).

For each coupler, an elastic shortening of 0.009 inch (0.229 mm) is estimated at allowable shaft load, and a slip of 0.144 inch (3.658 mm) is estimated at allowable shaft load.

4.1.4 Helice Capacity (P3): [Table 3](#) describes the allowable axial compression loads for helical bearing plates. For helical piles with more than one helix, the allowable helix capacity, P3, for the helical foundation systems and devices, may be taken as the sum of the least allowable capacity of each individual helix.

4.1.5 Soil Capacity (P4): [Table 4](#) describes the geotechnical related properties of the piles. The allowable compressive or tensile soil capacity (P4) must be determined by a registered design professional in accordance with a site-specific geotechnical report, as described in Section 4.1.1 combined with the individual helix bearing method (Method 1) or from field loading tests conducted under the supervision of a registered design professional (Method 2). For either Method 1 or Method 2, the predicted axial load capacities must be confirmed during the site-specific production installation, such that the axial load capacities predicted by the torque correlation method must be equal to or greater than what is predicted by Method 1 or 2, described above.

The individual bearing method is determined as the sum of the individual areas of the helical bearing plates times the ultimate bearing capacity of the soil or rock comprising the bearing stratum for helix plates. The design allowable axial capacity must be determined by dividing the total ultimate axial load capacity predicted by either Method 1 or 2, above, divided by a safety factor of at least 2.

With the torque correlation method, the ultimate axial soil capacity (P_{ult}) of the pile and the allowable axial soil capacity (P_a) of the pile are predicted as follows:

$$P_{\text{ult}} = K_t \times T \quad (\text{Equation 1})$$

$$P_a = 0.5 P_{\text{ult}} \quad (\text{Equation 2})$$

where:

P_{ult} = Ultimate axial compressive capacity (lbf or N) of helical pile, which must be limited to the maximum ultimate values noted in [Table 4](#).

P_a = Allowable axial compression capacity (lbf or N) of helical piles, which must be limited to the maximum allowable values noted in [Table 4](#).

K_t = Torque correlation factor per [Table 4](#).

T = Final installation torque defined as the last torque reading taken when terminating the helical pile installation, which must not exceed the maximum installation torque rating noted in [Table 4](#) of this report.

The allowable lateral soil capacity of the pile is 915 lbf (4.1 kN). It is based on field testing of the 27/8-inch-diameter (73 mm) helical pile with a single 8-inch-diameter (203 mm) helix plate installed in firm clay soil, having an average standard penetration test blow count of 20, at a minimum embedment of 16 feet (4.88 m). For soil conditions other than firm clay, the lateral capacity of the pile must be determined by a registered design professional.

4.2 Installation:

4.2.1 General: The Helical Anchors helical foundation systems must be installed by Helical Anchors trained and authorized installers. For tension application, the helical pile must be installed such that the minimum depth from the ground surface to the uppermost helix is 12D, where D is the diameter of the largest helix. The Helical Anchors helical foundation systems must be installed in accordance with this section (Section 4.2), IBC Section 1810.4.11, the site-specific approved construction documents (engineering plans and specifications), and the manufacturer's written installation instructions. In case of conflict, the most stringent requirement governs.

4.2.2 Helical Piles: The helical piles must be installed according to a preapproved plan of placement. Installation begins by attaching the helical pile lead section to the torque motor using a drive tool and drive pin. Next, crowd must be applied to force the pilot point into the ground at the proper location, inclination, and orientation, as described in the placement plan. Then the pile must be rotated into the ground in a smooth, clockwise, continuous manner while maintaining sufficient crowd to promote normal advancement. Installation continues by adding extension sections as necessary. Refer to Sections 3.2.1 and 3.3.6 of this report and the approved construction documents for type, grade, size and number of bolts and nuts that are required to connect the shaft sections. Inclination and alignment shall be checked and adjusted periodically during installation. Connection bolts between shaft sections shall be snug-tightened as defined in Section J3 of AISC 360. Care shall be taken not to exceed the maximum installation torque rating (shown in [Table 4](#)) of the helical piles during installation. Helical piles must be advanced until axial capacity is verified by achieving the required final installation torque as indicated by the torque correlation method described in Section 4.1.5, and the minimum depth, if any, as specified by the geotechnical report Section 4.1.1.

4.2.3 Type A Side Load Brackets: Type A brackets must be installed as specified in the approved plans. Installation of brackets requires an area adjacent to the building foundation to be excavated at each location thus exposing the footing, column, steel wall, or grade beam. The area to be exposed should be a minimum width of 18 inches and should extend below the bottom of the footing or grade beam by a minimum of 12 inches. Any soil attached to the bottom of the footing or grade beam should be removed prior to bracket installation. The footing or grade beam must be propped by chipping away the irregularities from the side or bottom for a sure bracket attachment. Existing concrete footing or grade beam capacity must not be altered, such as notching of concrete or cutting of reinforcing steel, without the approval of the registered design professional and the code official. Prepping of the footing allows for the bracket to be mounted to a reasonably flat, smooth, and full bearing surface. The bracket to the foundation or grade beam may be connected by using two concrete anchor bolts. The bracket is rotated into place under the existing concrete footing or grade beam and raised into position. Any excess pile length will be cut off level to enable the mounting of the bracket. The T-pipe will be placed over the helical pile and bracket. The threaded rods, steel bolts, hex nuts, and washers, supplied with the bracket, are added to hold the bracket in position. The hex nuts shall be snug tightened, as defined in Section J3 of AISC 360. Coupling nuts, jacking bracket, and lifting jack are installed to raise the foundation to the desire elevation. Any lifting of the existing structure must be verified by a registered design professional and is subjected to approval of the code official to ensure that the foundation, superstructure, and helical piles are not overstressed. Once the foundation has been raised to its desired elevation, the hex nuts over the T-pipe are tightened, and the jacking brackets and lifting jacks are removed. The field cutting and bolting must be in accordance with the most restrictive requirements as described in the evaluation report, the IBC, AISC 360, and the manufacturer's written instructions. The excavation must be backfilled in accordance with IBC Section 1804.

4.2.4 Type B and Type B-1 Direct Load Brackets: Type B and Type B-1 brackets must be placed over the top of the helical piles. The top of the pile elevation must be established and must be consistent with the specified elevation. If necessary, the top of the pile may be cut off level to the required length in accordance with the manufacturer's instructions and AISC 360 requirements so as to ensure full, direct bearing contact between the top of the pile shaft and the bracket. In the case of using Type B bracket, three ¾-inch-diameter

(19 mm) bolts and hex nuts as described in Section 3.3.6 of this report must be installed. Whereas Type B-1 brackets will utilize one ¾-inch-diameter (19 mm) bolt and hex nut. The bolts must be signed tightened, as defined in Section J3 of AISC 360. The embedment and edge distance of the bracket into the concrete foundation must be as described in the approved plans and as indicated in [Table 1](#) of this report. The concrete foundation must be cast around the bracket in accordance with the approved construction documents.

4.3 Special Inspection:

Special inspections in accordance with IBC Section 1705.9 (Section 1704.10 for 2009 IBC) must be performed continuously during installation of Helical Anchors helical foundation systems (piles and brackets). Items to be recorded and confirmed by the special inspector must include, but are not limited to, the following:

1. Verification of the product manufacturer, the manufacturer's certification of installers.
2. Product identification including lead sections, couplings, extension sections, brackets, bolts, and nuts, as specified in the construction documents and this evaluation report.
3. Installation equipment used.
4. Written installation procedures.
5. Tip elevations, the installation torque and final depth of the helical foundation systems.
6. Inclination and position/location of helical piles.
7. Tightness of all bolted connections.
8. Verification that direct load bracket cap plates are in full contact with the top of the pile shaft.
9. Compliance of the installation with the approved construction documents and this evaluation report.

5.0 CONDITIONS OF USE:

The Helical Anchors helical foundation systems described in this report, comply with or are suitable alternative to what is specified in, the code listed in Section 1.0 of this report, subject to the following conditions:

- 5.1 The Helical Anchors helical foundation systems are manufactured, identified, and installed in accordance with this report, the site-specific approved construction documents (engineering plans and specifications), IBC Section 1810.4.11, and the manufacturer's written installation instructions. In case of conflict, the most stringent requirement governs.
- 5.2 The Helical Anchors helical foundation systems have been evaluated for support of structures assigned to Seismic Design Categories A, B and C in accordance with IBC Section 1613. Helical foundation systems that support structures assigned to Seismic Design Category D, E or F, or that are located in Site Class E or F, are outside the scope of this report, and are subject to the approval of the code official based upon submission of a design in accordance with the code by a registered design professional.
- 5.3 Type A (Side Load), Type B (Direct Load), and Type B-1 (Direct Load) brackets must be used only to support structures that are laterally braced as defined in IBC Section 1810.2.2. Shaft couplings must be located within firm or soft soil as defined in Section 4.1.3.
- 5.4 The installations of Type A (Side Load), Type B (Direct Load), and Type B-1 (Direct Load) brackets are limited to regions of concrete members where analysis indicates no cracking at service load levels.
- 5.5 The Helical Anchors helical foundation systems when used in conditions that are indicative of potential pile deterioration or corrosion situations as defined by the following: (1) soil resistivity less than 1,000 ohm-cm; (2) soil pH less than 5.5; (3) soils with high organic content; (4) soil sulfate concentrations greater than 1,000 ppm; (5) soils located in landfill, or (6) soil containing mine waste are beyond scope of this report.
- 5.6 Zinc-coated steel and bare steel components must not be combined in the same system. All helical foundation components must be galvanically isolated from concrete reinforcing steel, building structural steel, or any other metal building components.
- 5.7 The helical piles must be installed vertically into the ground with the maximum allowable angle of inclination of 1 degree.
- 5.8 Engineering calculations and drawings, in accordance with recognized engineering principles, as described in IBC Section 1604.4, and complying with Section 4.1 of this report, prepared by a registered design professional, are provided to, and are approved by the code official.
- 5.9 The adequacy of the concrete structures that are connected to the Helical Anchors brackets must be verified by a registered design professional, in accordance with applicable code provisions, such as Chapter 13 of

ACI 318-14 for the 2018 and 2015 IBC (Chapter 15 of ACI 318-11 for the 2012 IBC and ACI 318-08 for the 2009 IBC) and Chapter 18 of IBC, and subject to the approval of the code official.

- 5.10 A geotechnical investigation report for each project site in accordance with Section 4.1.1 of this report must be provided to the code official for approval.
- 5.11 Special inspection is provided in accordance with Section 4.3 of this report.
- 5.12 When using the alternative basic load combinations prescribed in IBC Section 1605.3.2, the allowable stress increases permitted by material chapters of the IBC, or the referenced standards are prohibited.
- 5.13 The applied loads must not exceed the allowable capacities described in Section 4.1 of this report.
- 5.14 In order to avoid group efficiency effects, an analysis prepared by a registered design professional must be submitted where the center-to-center spacing of axially loaded helical piles is less than three times the diameter of the largest helix plate at the depth of bearing. An analysis prepared by a registered design professional must also be submitted where the center-to-center spacing of laterally loaded helical piles is less than eight times the least horizontal dimension of the pile shaft at the ground surface. Spacing between helical plates must not be less than 3D, where D is the diameter of the largest helical plate measured from the edge of the helical plate to the edge of the helical plate of the adjacent helical pile; or 4D, where the spacing is measured from the center-to-center of the adjacent helical pile plates.
- 5.15 Requirements described in footnotes of tables in this report must be satisfied.
- 5.16 Evaluation of compliance with IBC Section 1810.3.11.1 for buildings assigned to Seismic Design Category (SDC) C, and with IBC Section 1810.3.6 for all buildings, is outside of the scope of this evaluation report. Such compliance must be addressed by a registered design professional for each site and is subject to approval by the code official.
- 5.17 Settlement of helical piles is beyond the scope of this evaluation report and must be determined by a registered design professional as required in IBC Section 1810.2.3.
- 5.18 The Helical Anchors helical foundation systems are manufactured at the Helical Anchors, Inc. facility located in Minneapolis, Minnesota and Gujarat, India, under a quality-control program with inspections by ICC-ES.

6.0 EVIDENCE SUBMITTED

Data in accordance with the [ICC-ES Acceptance Criteria for Helical Pile Systems and Devices \(AC358\)](#), dated September 2017 (Editorially revised September 2018).

7.0 IDENTIFICATION

- 7.1 The Helical Anchors, Inc. (Helical Anchors) helical foundation systems (including lead shafts, extension shafts, brackets, and boxed hardware) are identified by a tag or label bearing the logo, name, and address of Helical Anchor, the product number, the evaluation report number (ESR-3982), and order number.
- 7.2 The report holder's contact information is the following:

HELICAL ANCHORS, INC.
5101 BOONE AVENUE NORTH
MINNEAPOLIS, MINNESOTA 55428
UNITED STATES OF AMERICA
(763) 201-6552
www.heilcalanchorsinc.com
girish@heilcalanchorsinc.com

- 7.3 The additional listee's contact information is the following:

BHUIJ POLYMERS PRIVATE LIMITED.
SURVEY NO 339/1, PAIKI 1,
VILLAGE SAMAGHOGHA,
TALUKA MUNDRA, KUTCH DISTRICT
GUJARAT 370415
INDIA
+91 (937) 747-4421
www.bhujpolymers.com
lokesh@bhujpolymers.com

TABLE 1—BRACKET CAPACITY (P1) FOR DIRECT LOAD BRACKETS^{1,2}

BRACKET TYPE	PRODUCT NUMBER	SHAFT DIAMETER (inches)	(P1) ALLOWABLE CAPACITY (kips)		
			2,500 psi Concrete Minimum		
			Compression	Tension	Lateral
Type A (Side Load) Bracket	SDB	2 ⁷ / ₈	30.2	N/A	N/A
Type B (Direct Load) Bracket	NCCH2788834	2 ⁷ / ₈	45.0 ³	30.1 ⁴	0.91 ⁵
Type B-1 (Direct Load) Bracket	NCCH2788812	2 ⁷ / ₈	21.9 ³	10.8 ⁴	0.91 ⁵

For SI: 1 kip = 4.448 kN, 1 psi = 6.895 kPa.

¹ Only localized limit states of supporting concrete including bearing and 2-way punching shear have been evaluated. Refer to Sections 5.4 and 5.9 of this report for additional requirements.

² Allowable capacities include an allowance for corrosion over a 50-year service life and presume the supported structure is braced in accordance with IBC Section 1810.2.2.

³ The allowable compressive load capacity is based on the mechanical strength of the steel bracket, concrete punching shear capacity, and concrete bearing strength. The allowable load capacities have been determined assuming that minimum reinforcement has been provided as specified by ACI 318-14 Section 9.6.1.2 and ACI 318-11 Section 10.5.1. The minimum embedment of the bracket is 10.76-inches. The embedment depth is the distance between the top of the bracket plate to the top of the concrete footing. End of helical pile shaft must be fully bearing on bracket plate. For Type B bracket, the concrete footing must have a minimum thickness of 14.5-inches and a minimum width of 29.5-inches and must be normal-weight concrete having a minimum compressive strength of 2,500 psi. For Type B-1 bracket, the concrete footing must have a minimum thickness of 10.2-inches and a minimum width of 21.4-inches and must be normal-weight concrete having a minimum compressive strength of 2,500 psi.

⁴ The allowable tensile load capacity is based on the mechanical strength of the steel bracket, punching shear capacity and bearing to concrete footing. The allowable load capacities have been determined assuming that minimum reinforcement has been provided as specified by ACI 318-14 Section 9.6.1.2 and ACI 318-11 Section 10.5.1. For Type B bracket, the minimum embedment of the bracket is 10.3-inches. The embedment depth is the distance between the bottom of the bracket plate to the bottom of the concrete footing. The capacity is based using three ¾-inch through bolts as described in Section 3.3.6 of this report. The concrete footing must have a minimum width of 24.6-inches and must be normal-weight concrete having a minimum compressive strength of 2,500 psi. For Type B-1 bracket, the minimum embedment of the bracket is 6.0-inches. The embedment depth is the distance between the bottom of the bracket plate to the bottom of the concrete footing. The capacity is based using one ¾-inch through bolt as described in Section 3.3.6 of this report. The concrete footing must have a minimum width of 16.1-inches and must be normal-weight concrete having a minimum compressive strength of 2,500 psi.

⁵ The allowable lateral capacity is based on limit states associated with mechanical steel strength, concrete breakout in accordance with ACI 318, and bracket bearing on unreinforced concrete in accordance with ACI 318. The bracket must be installed with a minimum embedment depth of 4 inches measured from the bottom of the bracket plate to the bottom of the concrete footing, and a minimum edge distance of 4 inches measured from the bracket plate edge to the concrete footing edge. The concrete footing must have a minimum width of 16 inches and must be normal-weight concrete having a minimum compressive strength of 2,500 psi.

TABLE 2A—SHAFT ALLOWABLE CAPACITY (P2)¹

SHAFT TYPE	UNBRACED SHAFT LENGTH, L _u (FT) 2	(P2) ALLOWABLE CAPACITY (KIPS)					
		COMPRESSION (KIPS) ^{3,4}			TENSION (KIPS)	LATERAL SHEAR (KIPS)	BENDING MOMENT (KIP-FT)
		0 Coupler	1 Coupler	2 Couplers			
2 ⁷ / ₈ " OD (0.217-inch wall thickness)	0	60	50.2	31.0	60	20	4.7
	5	31.9	27.6	20.5			
	10	20.9	19.0	15.4			

For SI: 1 inch = 25.4 mm, 1 kip = 4.448 kN.

¹ Allowable capacities include an allowance for corrosion over a 50-year service life.

² L_u = Total unbraced pile length per 2015, 2012, and 2009 IBC Section 1810.2.1, including the length in air, water or in fluid soils, and the embedment length into firm or soft soil (non-fluid soil). kL_u = total effective unbraced length of the pile, where kL_u = 0 represent a fully braced condition in that the total pile length is fully embedded in firm or soft soil and the supported structure is braced in accordance to IBC Section 1810.2.2.

³ Number of couplings within L_u.

⁴ The capacities shown in Table 2(A) are for 2⁷/₈-inch-diameter (0.217-inch wall thickness) piles installed with a maximum 1 degree of inclination from vertical and do not include the brackets as described in Sections 4.2.3 and 4.2.4. The capacities are also based on the assumption that the pile shaft is concentrically loaded.

TABLE 2B—MECHANICAL PROPERTIES AFTER CORROSION LOSS¹ OF 2.875-INCH DIAMETER HELICAL SHAFT

Mechanical Properties	2.875-inch (0.217-inch wall thickness)
Steel Yield Strength, F_y (ksi)	80
Steel Ultimate Strength, F_u (ksi)	100
Modulus of Elasticity, E (ksi)	29,000
Nominal Wall Thickness (inch)	0.217
Design Wall Thickness (inch)	0.166
Outside Diameter (inch)	2.839
Inside Diameter (inch)	2.507
Cross Sectional Area (inch ²)	1.39
Moment of Inertia, I (inch ⁴)	1.25
Radius of Gyration, r (inch)	0.95
Section Modulus, S (inch ³)	0.88
Plastic Section Modulus, Z (inch ³)	1.19

For **SI**: 1 inch = 25.4 mm; 1 ksi = 6.89 MPa, 1 ft-lbf = 1.36 N-m; 1 lbf = 4.45 N.

¹ Dimensional properties are based on bare steel losing 0.036-inch steel thickness as indicated in Section 3.9 of AC308 for a 50-year service life.

TABLE 3—HELICAL BEARING PLATE CAPACITY (P3) – AXIAL COMPRESSION^{1,2}

HELIX DIAM. (IN)	SHAFT TYPE	HELIX THICKNESS (IN)	HELIX PITCH (IN)	ALLOWABLE CAPACITY ³ (P3) (KIPS)
8	2.875-inch (0.217-inch wall thickness)	0.375	3.0	57.8
10	2.875-inch (0.217-inch wall thickness)	0.375	3.0	40.0
12	2.875-inch (0.217-inch wall thickness)	0.375	3.0	52.2
14	2.875-inch (0.217-inch wall thickness)	0.375	3.0	40.5

For **SI**: 1 inch = 25.4 mm, 1 kip = 4.448 kN.

¹For helical piles with more than one helix, the allowable helix capacity, P3, for the helical foundation systems, may be taken as the sum of the least allowable capacity of each individual helix.

²As described in Section 3.2.1 of this report, all helical bearing plates are made from same material, and have the same edge geometry, thickness and pitch.

³Allowable capacities include an allowance for corrosion over a 50-year service life.

TABLE 4—SOIL CAPACITY (P4)^{1,6}

GEOTECHNICAL RELATED PROPERTIES	Axial Tension	Axial Compression
Mechanical Torsion Rating (ft-lbs) ³	12,596	12,596
Maximum Torque Per Soil Tests (ft-lbs) ⁴	11,000	12,500
Maximum Installation Torque Rating (ft-lbs) ⁵	11,000	12,500
Torque Correlation Factor, K_t (ft ⁻¹)	8.0	8.5
Maximum Ultimate Soil Capacity / Maximum Allowable Soil Capacity (P4) from Torque Correlations (kips) ²	88.0/44.0	106.2/53.1

For **SI**: 1 foot = 0.305 m, 1 lbf = 4.448 N, 1 lbf-ft = 1.356 N-m.

¹ Soil capacity (P4) must be determined per Section 4.1.5 of this report.

² Maximum ultimate soil capacity is determined from $P_{ult} = K_t \times T$ based on the corresponding maximum installation torque rating for the specific pile model. Allowable soil capacity is determined from $P_a = P_{ult} / 2.0$ based on the corresponding maximum installation torque rating for the specific pile model. See Section 4.1.5 for additional information.

³ Mechanical torsion rating is the maximum torsional resistance of the steel shaft.

⁴ Maximum Torque Per Soil Tests is the maximum torque achieved during field axial verification testing that was conducted to verify the pile axial capacity related to pile-soil interaction.

⁵ Maximum Installation Torque rating is the lower of the “mechanical torsion rating” and the “maximum torque per soil tests”.

⁶ See Section 4.1.5 for the lateral soil capacity.

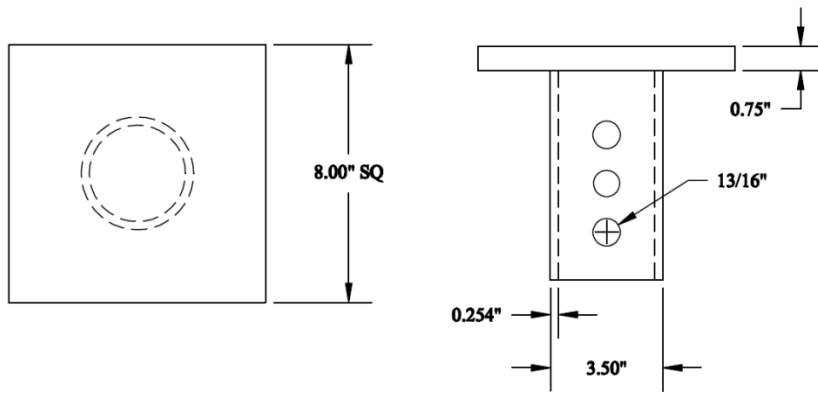

FIGURE 1—TYPE B BRACKET

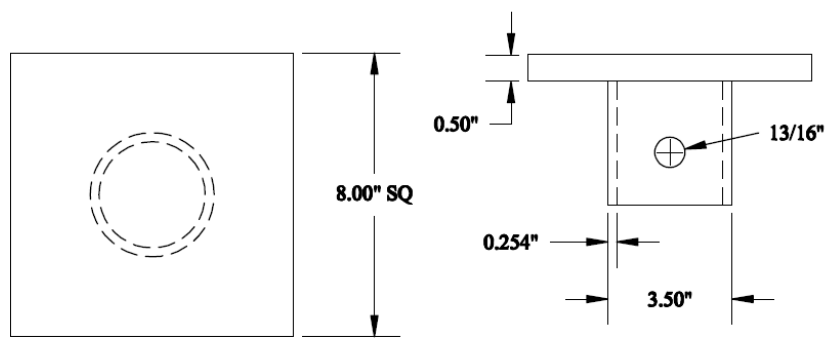

FIGURE 2—TYPE B-1 BRACKET

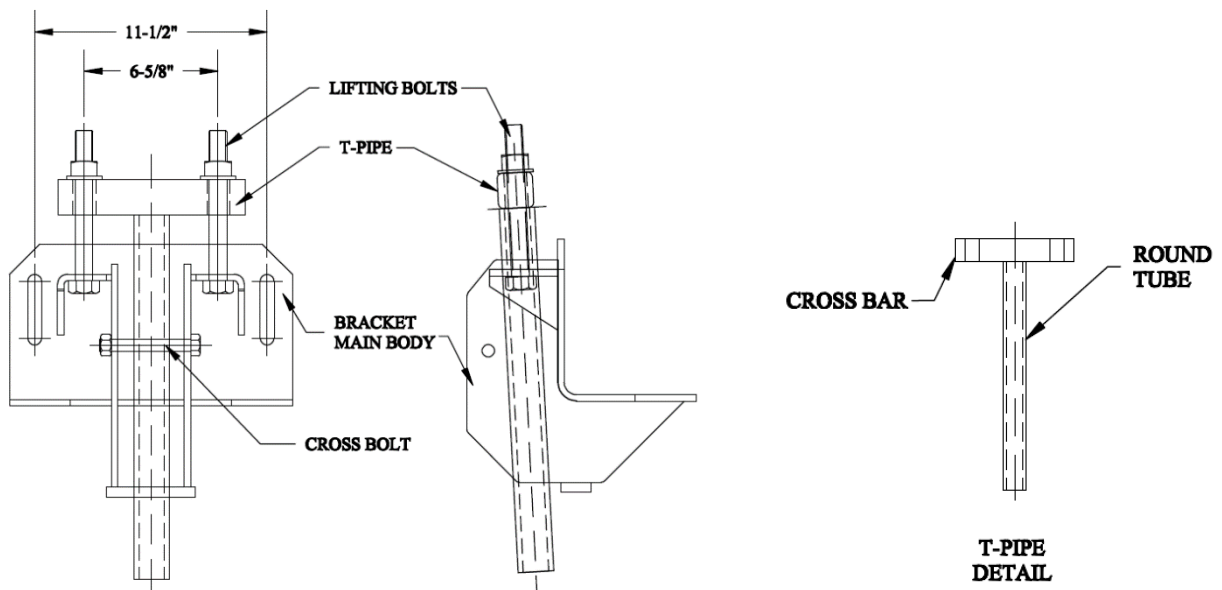
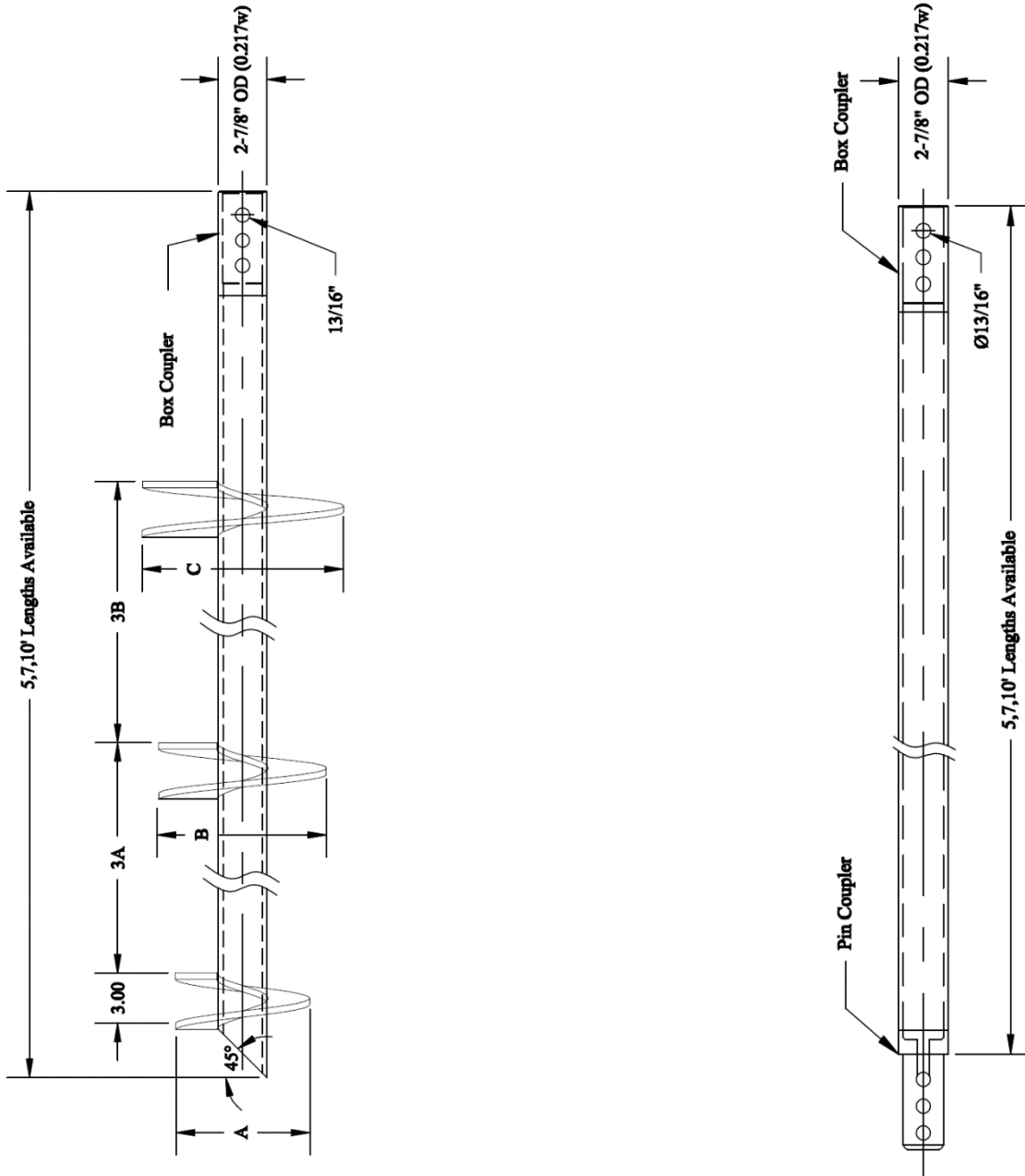

FIGURE 3—TYPE A BRACKET



HELICAL LEAD SHAFT SECTION

HELICAL EXTENSION SHAFT SECTION

FIGURE 4—HELICAL LEAD SECTION AND EXTENSION SECTION (TYPICAL)

DIVISION: 31 00 00—EARTHWORK

Section: 31 63 00—Bored Piles

REPORT HOLDER:

HELICAL ANCHORS, INC.

EVALUATION SUBJECT:

HELICAL ANCHORS HELICAL FOUNDATION SYSTEMS

1.0 REPORT PURPOSE AND SCOPE

Purpose:

The purpose of this evaluation report supplement is to indicate that the Helical Anchors Helical Foundation Systems, described in ICC-ES evaluation report ESR-3982, have also been evaluated for compliance with the code noted below.

Applicable code edition:

2019 *California Building Code* (CBC)

For evaluation of applicable chapters adopted by the California Office of Statewide Health Planning and Development (OSHPD) and Division of State Architect (DSA), see Sections 2.1.1 and 2.1.2 below.

2.0 CONCLUSIONS

2.1 CBC:

The Helical Anchors Helical Foundation Systems, described in Sections 2.0 through 7.0 of the evaluation report ESR-3982, complies with CBC Chapter 18, provided the design and installation are in accordance with the 2018 *International Building Code*® (IBC) provisions noted in the evaluation report and the additional requirements of CBC Chapters 17 and 18, as applicable.

2.1.1 OSHPD:

The applicable OSHPD Sections and Chapters of the CBC are beyond the scope of this supplement.

2.1.2 DSA:

The applicable DSA Sections and Chapters of the CBC are beyond the scope of this supplement.

This supplement expires concurrently with the evaluation report, reissued September 2023.