



DIVISION: 03 00 00—CONCRETE

Section: 03 16 00—Concrete Anchors

DIVISION: 05 00 00—METALS

Section: 05 05 19—Post-installed Concrete Anchors

REPORT HOLDER:

FASTENAL COMPANY

EVALUATION SUBJECT:

FASTENAL FC10+ ADHESIVE ANCHOR SYSTEM IN CRACKED AND UNCRACKED CONCRETE

1.0 EVALUATION SCOPE

Compliance with the following codes:

- 2015, 2012, and 2009 *International Building Code*® (IBC)
- 2015, 2012, and 2009 *International Residential Code*® (IRC)

Property evaluated:

Structural

2.0 USES

The FC10+ adhesive anchors are used to resist static, wind, or earthquake (Seismic Design Categories A through F) tension and shear loads in cracked and uncracked normal-weight concrete or lightweight concrete with 1/2-, 5/8-, 3/4-, 7/8- and 1-inch-diameter (12.7, 15.9, 19.1, 22.2 and 25.4 mm) threaded steel rods and No. 4 through No. 8 steel reinforcing bars; and are used to resist static, wind and earthquake (IBC Seismic Design Categories A and B only) tension and shear loads in uncracked normal-weight concrete only with 3/8-inch-diameter (9.5 mm) threaded steel rods and No. 3 steel reinforcing bars in hammer-drilled holes in uncracked normal-weight concrete having a specified compressive strength, f'_c , of 2,500 psi to 8,500 psi (17.2 MPa to 58.6 MPa).

The anchor system complies with anchors as described in Section 1901.3 of the 2015 IBC, Section 1909 of the 2012 IBC and is an alternative to anchors described in Sections 1908 of the 2012 IBC; and Sections 1911 and 1912 of the 2009 IBC. The anchor systems may also be used where an engineered design is submitted in accordance with Section R301.1.3 of the IRC.

3.0 DESCRIPTION

3.1 General:

The FC10+ Adhesive Anchor System is comprised of FC10+ two-component adhesive filled in cartridges, static

mixing nozzles, manual or powered dispensing tools, hole cleaning equipment, and adhesive injection accessories. The FC10+ adhesive may be used with continuously threaded steel rods or deformed steel reinforcing bars. The primary components of the FC10+ Adhesive Anchor System, including the FC10+ adhesive cartridge, static mixing nozzle, the nozzle extension tube and steel anchor elements, are shown in Figure 3 of this report. Manufacturer's printed installation instructions (MPII) and parameters, included with each adhesive unit package, are shown in Figure 4 of this report.

3.2 Materials:

3.2.1 FC10+ Adhesive: The FC10+ adhesive is an injectable two-component vinylester adhesive. The two components are kept separate by means of a labeled dual-cylinder cartridge. The two components combine and react when dispensed through a static mixing nozzle, supplied by Fastenal, which is attached to the cartridge. FC10+ is available in 10-ounce (280 mL) and 28-ounce (825 mL) cartridges. Each cartridge label is marked with the adhesive expiration date. The shelf life, as indicated by the expiration date, applies to an unopened cartridge stored in a dry, dark, and cool environment.

3.2.2 Hole Cleaning Equipment: Hole cleaning equipment is comprised of steel wire brushes supplied by Fastenal, and air blowers which are shown in Figure 5 of this report.

3.2.3 Dispensers: FC10+ adhesive must be dispensed with manual dispensers, pneumatic dispensers, or electric powered dispensers supplied by Fastenal.

3.2.4 Steel Anchor Elements:

3.2.4.1 Threaded Steel Rods: Threaded steel rods must be clean and continuously threaded (all-thread) in diameters described in Table 1 of this report. Specifications for grades of threaded rod, including the mechanical properties, and corresponding nuts, are included in Table 2. Carbon steel threaded rods must be furnished with a minimum 0.0002-inch-thick (0.005 mm) zinc electroplated coating complying with ASTM B633 SC 1 or a minimum 0.0021-inch-thick (0.053 mm) mechanically deposited zinc coating complying with ASTM B695, Class 55; or hot dip galvanized zinc coating complying with ASTM A153, Class C or D. The stainless steel threaded rods must comply with Table 2 of this report. Steel grades and types of material (carbon, stainless) for the washers and nuts must match the threaded rods. Threaded steel rods must be clean, straight and free of indentations or other defects along their length. The embedded end may be flat cut or cut on the bias to a chisel point.

3.2.4.2 Steel Reinforcing Bars: Steel reinforcing bars are deformed reinforcing bars (rebar) in sizes as described in Table 1 of this report. The embedded portions of reinforcing bars must be clean, straight, and free of mill scale, rust and other coatings (other than zinc) that may impair the bond with the adhesive. Reinforcing bars must not be bent after installation except as set forth in ACI 318-14 26.6.3.1 (b) or ACI 318-11 7.3.2, as applicable, with the additional condition that the bars must be bent cold, and heating of reinforcing bars to facilitate field bending is not permitted.

3.2.4.3 Ductility: In accordance with ACI 318-14 2.3 or ACI 318-11 D.1, as applicable, in order for a steel anchor element to be considered ductile, the tested elongation must be at least 14 percent and reduction of area must be at least 30 percent. Steel elements with a tested elongation of less than 14 percent or a reduction of area less than 30 percent, or both, are considered brittle. Values for various steel materials are provided in Table 2 of this report. Where values are nonconforming or unstated, the steel must be considered brittle.

3.3 Concrete:

Normal-weight concrete and lightweight concrete must comply with Sections 1903 and 1905 of the IBC, as applicable. The specified compressive strength of the concrete must be from 2,500 psi to 8,500 psi (17.2 MPa to 58.6 MPa).

4.0 DESIGN AND INSTALLATION

4.1 Strength Design:

4.1.1 General: The design strength of anchors under the 2015 IBC, as well as the 2015 IRC, must be determined in accordance with ACI 318-14 and this report. The design strength of anchors under the 2012 and 2009 IBC, as well as the 2012 and 2009 IRC must be determined in accordance with ACI 318-11 and this report.

The strength design of anchors must comply with ACI 318-14 17.3.1 or ACI 318-11 D.4.1, as applicable, except as required in ACI 318-14 17.2.3 or ACI 318-11 D.3.3, as applicable.

Design parameters are provided in Table 4 through Table 8 of this report. Strength reduction factors, ϕ , as given in ACI 318-14 17.3.3 or ACI 318-11 D.4.3, as applicable, must be used for load combinations calculated in accordance with Section 1605.2 of the IBC, ACI 318-14 5.3 or ACI 318-11 9.2, as applicable. Strength reduction factors, ϕ , as described in ACI 318-11 D.4.4 must be used for load combinations calculated in accordance with ACI 318-11 Appendix C.

4.1.2 Static Steel Strength in Tension: The nominal static steel strength of a single anchor in tension, N_{sa} , in accordance with ACI 318-14 17.4.1.2 or ACI 318-11 D.5.1.2, as applicable, and the associated strength reduction factors, ϕ , in accordance with ACI 318-14 17.3.3 or ACI 318-11 D.4.3, as applicable, are provided in Table 4 and Table 5 of this report for the anchor element types included in this report. See Table 1 for design use and table index.

4.1.3 Static Concrete Breakout Strength in Tension: The nominal concrete breakout strength of a single anchor or group of anchors in tension, N_{cb} or $N_{c,cbg}$, must be calculated in accordance with ACI 318-14 17.4.2 or ACI 318-11 D.5.2, as applicable, with the following addition:

The basic concrete breakout strength of a single anchor in tension, N_b , must be calculated in accordance with ACI 318-14 17.4.2.2 or ACI 318-11 D.5.2.2, as applicable using the selected values of $K_{c,cr}$ and $K_{c,uncr}$ as provided in the tables of this report. Where analysis indicates no cracking in

accordance with ACI 318-14 17.4.2.6 or ACI 318-11 D.5.2.6, as applicable, N_b must be calculated using $K_{c,uncr}$ and $\Psi_{c,N} = 1.0$. See Table 1 for additional design information. See ACI 318-14 17.2.6 or ACI 318-11 D.3.6, as applicable, for modification factor, λ_a , for lightweight concrete. The value of f'_c used for calculation must be limited to 8,000 psi (55 MPa) in accordance with ACI 318-14 17.2.7 or ACI 318-11 D.3.7, as applicable. Additional information for the determination of nominal bond strength in tension is given in Section 4.1.4 of this report.

4.1.4 Static Bond Strength in Tension: The nominal static bond strength of a single adhesive anchor or group of adhesive anchors in tension, N_a or N_{ag} , must be calculated in accordance with ACI 318-14 17.4.5 or ACI 318-11 D.5.5, as applicable. Bond strength values ($\tau_{k,cr}$, $\tau_{k,uncr}$) are a function of concrete compressive strength (f'_c), concrete state (cracked, uncracked), concrete type (normal weight, lightweight), and installation conditions (dry concrete, water-saturated concrete, water-filled holes). Bond strength values must further be modified with the factor K_{rn} for cases the holes are water-filled at the time of anchor installation (K_{wrf}). Special inspection level is qualified as periodic for all anchors except as noted in Section 4.4 of this report (the selection of continuous special inspection level does not provide an increase in anchor category or associated strength reduction factors for design). The following table summarizes the requirements:

CONCRETE STATE	CONCRETE TYPE	DRILLING METHOD	BOND STRENGTH	CONCRETE COMPRESSIVE STRENGTH	PERMISSIBLE INSTALLATION CONDITIONS	ASSOCIATED STRENGTH REDUCTION FACTOR
Cracked	Normal weight or lightweight	Hammer-drill	$\tau_{k,cr}$	f'_c	Dry concrete	ϕ_d
					Water-saturated concrete	ϕ_{ws}
					Water-filled hole (flooded)	ϕ_{wf}
Uncracked	Normal weight or lightweight	Hammer-drill	$\tau_{k,uncr}$	f'_c	Dry concrete	ϕ_d
					Water-saturated concrete	ϕ_{ws}
					Water-filled hole (flooded)	ϕ_{wf}

The bond strength values in Table 7 and Table 8 for hammer-drilled holes, correspond to concrete compressive strength f'_c equal to 2,500 psi (17.2 MPa) in normal weight concrete. See ACI 318-14 17.2.6 or ACI 318-11 D.3.6, as applicable, for modification factor, λ_a , for lightweight concrete. For concrete compressive strength, f'_c between 2,500 psi and 8,000 psi (17.2 MPa and 55.2 MPa), the tabulated characteristic bond strength may be increased by a factor of $(f'_c / 2,500)^{0.1}$ [For **SI**: $(f'_c / 17.2)^{0.1}$]. Where applicable, the modified bond strength values must be used in lieu of $\tau_{k,cr}$ and $\tau_{k,uncr}$ in ACI 318-14 Equations (17.4.5.1d) and (17.4.5.2) or ACI 318-11 Equations (D-21) and (D-22), as applicable. The resulting nominal bond strength must be multiplied by the associated strength reduction factor ϕ_d , ϕ_{ws} or ϕ_{wf} , as applicable.

Figure 1 of this report presents a bond strength design selection flowchart. Strength reduction factors for determination of the bond strength are given in Table 7 and Table 8 of this report. See Table 1 for index of design tables. Adjustments to the bond strength may also be made for increased concrete compressive strength as noted above and in the footnotes to the corresponding tables.

4.1.5 Static Steel Strength in Shear: The nominal static strength of a single anchor in shear, as governed by the steel, V_{sa} , in accordance with ACI 318-14 17.5.1.2 or ACI 318-11 D.6.1.2, as applicable, and the strength reduction factors, ϕ , in accordance with ACI 318-14 17.3.3 or ACI 318-11 D.4.3, as applicable, are given in Table 4 and Table 5 of this report for the anchor element types included in this report. See Table 1 for index of design tables.

4.1.6 Static Concrete Breakout Strength in Shear: The nominal concrete breakout strength of a single anchor or group of anchors in shear, V_{cb} or V_{cbg} , must be calculated in accordance with ACI 318-14 17.5.2 or ACI 318-11 D.6.2, as applicable, based on information given in Table 6 of this report. The basic concrete breakout strength of a single anchor in shear, V_b , must be calculated in accordance with ACI 318-14 17.5.2.2 or ACI 318-11 D.6.2.2, as applicable, using the values of d given in Table 6 for the corresponding anchor steel in lieu of d_a (2015, 2012 and 2009 IBC). In addition, h_{ef} must be substituted for ℓ_e . In no case must ℓ_e exceed $8d$. See ACI 318-14 17.2.6 or ACI 318-11 D.3.6, as applicable, for modification factor, λ_a , for lightweight concrete. The value of f'_c must be limited to a maximum of 8,000 psi (55 MPa) in accordance with ACI 318-14 17.2.7 or D.3.7 ACI 318-11 D.3.7, as applicable.

4.1.7 Static Concrete Pryout Strength in Shear: The nominal static pryout strength of a single anchor or group of anchors in shear, V_{cp} or V_{cpg} , shall be calculated in accordance with ACI 318-14 17.5.3 or ACI 318-11 D.6.3, as applicable.

4.1.8 Interaction of Tensile and Shear Forces: For designs that include combined tension and shear, the interaction of tension and shear loads must be calculated in accordance with ACI 318-14 17.6 or ACI 318-11 D.7, as applicable.

4.1.9 Minimum Member Thickness h_{min} , Anchor Spacing s_{min} , Edge Distance c_{min} : In lieu of ACI 318-14 17.7.1 and 17.7.3 or ACI 318-11 D.8.1 and D.8.3, as applicable, values of s_{min} and c_{min} described in this report must be observed for anchor design and installation. The minimum member thicknesses, h_{min} , described in this report must be observed for anchor design and installation. For adhesive anchors that will remain untorqued, ACI 318-14 17.7.4 or ACI 318-11 D.8.4, as applicable, applies.

For anchors that will be torqued during installation, the maximum torque, T_{max} , must be reduced for edge distances less than five anchor diameters ($5d$). T_{max} is subject to the edge distance, c_{min} , and anchor spacing, s_{min} , and shall comply with the following requirements:

MAXIMUM TORQUE SUBJECT TO EDGE DISTANCE			
NOMINAL ANCHOR SIZE, d	MIN. EDGE DISTANCE, c_{min}	MIN. ANCHOR SPACING, s_{min}	MAXIMUM TORQUE, T_{max}
all sizes	$5d$	$5d$	$1.0 \cdot T_{max}$
$\frac{3}{8}$ in. to 1 in. (9.5 mm to 25.4 mm)	1.75 in. (45 mm)	$5d$	$0.45 \cdot T_{max}$

For values of T_{max} , see Table 9 and Figure 4 of this report.

4.1.10 Critical Edge Distance c_{ac} and $\psi_{cp,Na}$: The modification factor $\psi_{cp,Na}$, must be determined in accordance with ACI 318-14 17.4.5.5 or ACI 318-11 D.5.5.5, as applicable, except as noted below:

For all cases where $c_{Na}/c_{ac} < 1.0$, $\psi_{cp,Na}$ determined from ACI 318-14 Eq. 17.4.5.5b or ACI 318-11 Eq. D-27, as applicable, need not be taken less than c_{Na}/c_{ac} . For all other cases, $\psi_{cp,Na}$ shall be taken as 1.0.

The critical edge distance, c_{ac} must be calculated according to Eq. 17.4.5.5c for ACI 318-14 or Eq. D-27a for

ACI 318-11, in lieu of ACI 318-14 17.7.6 or ACI 318-11 D.8.6, as applicable.

$$c_{ac} = h_{ef} \left(\frac{\tau_{k,uncr}}{1160} \right)^{0.4} \cdot \left[3.1 - 0.7 \frac{h}{h_{ef}} \right]$$

(Eq. 17.4.5.5c for ACI 318-14 or Eq. D-27a for ACI 318-11) where

$\left[\frac{h}{h_{ef}} \right]$ need not be taken as larger than 2.4; and

$\tau_{k,uncr}$ = the characteristic bond strength stated in the tables of this report whereby $\tau_{k,uncr}$ need not be taken as larger than:

$$\tau_{k,uncr} = \frac{k_{uncr} \sqrt{h_{ef} f'_c}}{\pi \cdot d_a} \quad \text{Eq. (4-1)}$$

4.1.11 Design Strength in Seismic Design Categories C, D, E and F: In structures assigned to Seismic Design Category C, D, E or F under the IBC or IRC, anchors must be designed in accordance with ACI 318-14 17.2.3 or ACI 318-11 D.3.3, as applicable, except as described below.

The nominal steel shear strength, V_{sa} , must be adjusted by $\alpha_{V,seis}$ as given in Tables 4 and 5 for the corresponding anchor steel. The nominal bond strength $\tau_{k,cr}$ must be adjusted by $\alpha_{N,seis}$ as given in Table 7 for threaded rods. An adjustment to the nominal bond strength $\tau_{k,cr}$ is not required for reinforcing bars ($\alpha_{N,seis} = 1.0$.)

As an exception to ACI 318-11 D.3.3.4.2: Anchors designed to resist wall out-of-plane forces with design strengths equal to or greater than the force determined in accordance with ASCE 7 Equation 12.11-1 or 12.14-10 shall be deemed to satisfy ACI 318-11 D.3.3.4.3(d).

Under ACI 318-11 D.3.3.4.3(d), in lieu of requiring the anchor design tensile strength to satisfy the tensile strength requirements of ACI 318-11 D.4.1.1, the anchor design tensile strength shall be calculated from ACI 318-11 D.3.3.4.4.

The following exceptions apply to ACI 318-11 D.3.3.5.2:

1. For the calculation of the in-plane shear strength of anchor bolts attaching wood sill plates of bearing or non-bearing walls of light-frame wood structures to foundations or foundation stem walls, the in-plane shear strength in accordance with ACI 318-11 D.6.2 and D.6.3 need not be computed and ACI 318-11 D.3.3.5.3 need not apply provided all of the following are satisfied:

1.1. The allowable in-plane shear strength of the anchor is determined in accordance with AF&PA NDS Table 11E for lateral design values parallel to grain.

1.2. The maximum anchor nominal diameter is $\frac{5}{8}$ inch (16 mm).

1.3. Anchor bolts are embedded into concrete a minimum of 7 inches (178 mm).

1.4. Anchor bolts are located a minimum of $1\frac{3}{4}$ inches (45 mm) from the edge of the concrete parallel to the length of the wood sill plate.

1.5. Anchor bolts are located a minimum of 15 anchor diameters from the edge of the concrete perpendicular to the length of the wood sill plate.

1.6. The sill plate is 2-inch or 3-inch nominal thickness.

2. For the calculation of the in-plane shear strength of anchor bolts attaching cold-formed steel track of bearing or non-bearing walls of light-frame construction to foundations or foundation stem walls, the in-plane shear strength in accordance with ACI 318-11 D.6.2 and D.6.3 need not be

computed and ACI 318-11 D.3.3.5.3 need not apply provided all of the following are satisfied:

- 2.1. The maximum anchor nominal diameter is $5/8$ inch (16 mm).
- 2.2. Anchors are embedded into concrete a minimum of 7 inches (178 mm).
- 2.3. Anchors are located a minimum of $1\ 3/4$ inches (45 mm) from the edge of the concrete parallel to the length of the track.
- 2.4. Anchors are located a minimum of 15 anchor diameters from the edge of the concrete perpendicular to the length of the track.
- 2.5. The track is 33 to 68 mil designation thickness. Allowable in-plane shear strength of exempt anchors, parallel to the edge of concrete shall be permitted to be determined in accordance with AISI S100 Section E3.3.1.

3. In light-frame construction, bearing or nonbearing walls, shear strength of concrete anchors less than or equal to 1 inch [25 mm] in diameter attaching a sill plate or track to foundation or foundation stem wall need not satisfy ACI 318-11 D.3.3.5.3(a) through (c) when the design strength of the anchors is determined in accordance with ACI 318-11 D.6.2.1(c).

4.2 Allowable Stress Design (ASD):

4.2.1 General: For anchors designed using load combinations in accordance with IBC Section 1605.3 (Allowable Stress Design) loads must be established using the equations below:

$$T_{allowable,ASD} = \phi N_n / \alpha \quad (\text{Eq. 4-2})$$

and

$$V_{allowable,ASD} = \phi V_n / \alpha \quad (\text{Eq. 4-3})$$

where

$T_{allowable,ASD}$ = Allowable tension load (lbf or kN).

$V_{allowable,ASD}$ = Allowable shear load (lbf or kN).

ϕN_n = Lowest design strength of an anchor or anchor group in tension as determined in accordance with ACI 318-14 Chapter 17 and 2015 IBC Section 1905.1.8, ACI 318-11 Appendix D, ACI 318-08 Appendix D and 2009 IBC Sections 1908.1.9 and Section 4.1 of this report, as applicable (lbf or kN).

ϕV_n = Lowest design strength of an anchor or anchor group in shear as determined in accordance with ACI 318-14 Chapter 17 and 2015 IBC Section 1905.1.8, ACI 318-11 Appendix D, ACI 318-08 Appendix D and 2009 Sections 1908.1.9 and Section 4.1 of this report, as applicable (lbf or kN).

α = Conversion factor calculated as a weighted average of the load factors for the controlling load combination. In addition, α must include all applicable factors to account for non-ductile failure modes and required over-strength.

4.2.2 Interaction of Tensile and Shear Forces: Interaction must be calculated in accordance with ACI 318-14 17.6 or ACI 318 (-11,-08) D.7, as applicable, as follows:

For shear loads $V \leq 0.2 V_{allowable,ASD}$, the full allowable load in tension shall be permitted.

For tension loads $T \leq 0.2 T_{allowable,ASD}$, the full allowable load in shear shall be permitted.

For all other cases:

$$\frac{T}{T_{allowable,ASD}} + \frac{V}{V_{allowable,ASD}} \leq 1.2 \quad \text{Eq. (4-4)}$$

4.3 Installation:

Installation parameters are illustrated in Figure 4 of this report. Installation must be in accordance with ACI 318-14 17.8.1 and 17.8.2 or ACI 318-11 D.9.1 and D.9.2, as applicable. Anchor locations must comply with this report and the plans and specifications approved by the code official. Installation of the FC10+ Adhesive Anchor System must conform to the manufacturer's printed installation instructions (MPII) as reproduced in each unit package as described in Figure 4. The injection tools, mixing nozzles, wire brushes, air blowers, and piston plugs along with the adhesive cartridges must be supplied by the manufacturer, as described in Figure 4 of this report.

4.4 Special Inspection:

Periodic special inspection must be performed where required in accordance with Section 1705.1.1 and Table 1705.3 of the 2015 and 2012 IBC or 1704.4 and 1704.15 of the 2009 IBC or Sections 1704.4 and 1704.15 of the 2009 IBC, and this report. The special inspector must be on the jobsite initially during anchor installation to verify the anchor type, anchor dimensions, concrete type, concrete compressive strength, adhesive identification and expiration date, hole dimensions, hole cleaning procedures, anchor spacing, edge distances, concrete thickness, anchor embedment, tightening torque and adherence to the manufacturer's printed installation instructions (MPII). The special inspector must verify the initial installations of each type and size of adhesive anchor by construction personnel on site. Subsequent installations of the same anchor type and size by the same construction personnel are permitted to be performed in the absence of the special inspector. Any change in the anchor product being installed or the personnel performing the installation requires an initial inspection. For ongoing installations over an extended period, the special inspector must make regular inspections to confirm correct handling and installation of the product.

Continuous special inspection of adhesive anchors installed in horizontal orientations to resist sustained tension loads shall be performed in accordance with ACI 318-14 17.8.2.4, 26.7.1(h) and 26.13.3.2(c) or ACI 318-11 D.9.2.4, as applicable. Overhead and upwardly inclined installation orientations are beyond the scope of this report.

Under the IBC, additional requirements as set forth in Sections 1705, 1706 or 1707 must be observed, where applicable.

5.0 CONDITIONS OF USE

The FC10+ Adhesive Anchor System described in this report complies with or is a suitable alternative to what is specified in the codes listed in Section 1.0 of this report, subject to the following conditions:

5.1 The FC10+ adhesive anchors must be installed in accordance with this report and the manufacturer's printed installation instructions (MPII) as included with each cartridge and described in Figure 4 of this report.

5.2 The anchors described in this report must be installed in cracked or uncracked normal-weight concrete or

lightweight concrete having a specified compressive strength, $f'_c = 2,500$ psi to 8,500 psi (17.2 MPa to 58.6 MPa).

- 5.3 The values of f'_c used for calculation purposes must not exceed 8,000 psi (55 MPa).
- 5.4 Anchors must be installed in concrete base materials in holes predrilled in accordance with the instructions provided in Figure 4 of this report.
- 5.5 Loads applied to the anchors must be adjusted in accordance with Section 1605.2 of the IBC for strength design and in accordance with Section 1605.3 of the IBC for allowable stress design.
- 5.6 The FC10+ adhesive anchors are recognized for use to resist short- and long-term loads, including wind and earthquake, subject to the conditions of this report.
- 5.7 In structures assigned to Seismic Design Categories C, D, E, and F under the IBC or IRC, anchor strength must be adjusted in accordance with Section 4.1.11 of this report.
- 5.8 The FC10+ Adhesive Anchor System is permitted to be installed in concrete that is cracked or that may be expected to crack during the service life of the anchor, subject to the conditions of this report.
- 5.9 Strength design values are established in accordance with Section 4.1 of this report.
- 5.10 Allowable stress design values are established in accordance with Section 4.2 of this report.
- 5.11 Minimum anchor spacing and edge distance, as well as minimum member thickness, must comply with the values described in this report.
- 5.12 Prior to installation, calculations and details demonstrating compliance with this report must be submitted to the code official. The calculations and details must be prepared by a registered design professional where required by the statutes of the jurisdiction in which the project is to be constructed.
- 5.13 Anchors are not permitted to support fire-resistive construction. Where not otherwise prohibited by the code, FC10+ adhesive anchors are permitted for installation in fire-resistive construction provided that at least one of the following conditions is fulfilled:
 - Anchors are used to resist wind or seismic forces only.
 - Anchors that support gravity load-bearing structural elements are within a fire-resistive envelope or a fire-resistive membrane, are protected by approved fire-resistive materials, or have been evaluated for resistance to fire exposure in accordance with recognized standards.
 - Anchors are used to support nonstructural elements.
- 5.14 Since an ICC-ES acceptance criteria for evaluating data to determine the performance of adhesive anchors subjected to fatigue or shock loading is unavailable at this time, the use of these anchors under such conditions is beyond the scope of this report.
- 5.15 Use of zinc-plated carbon steel threaded rods or steel reinforcing bars is limited to dry, interior locations.
- 5.16 Use of hot-dipped galvanized carbon steel and stainless steel rods is permitted for exterior exposure or damp environments.
- 5.17 Steel anchoring materials in contact with preservative-treated wood and fire-retardant-treated wood must be

of zinc-coated carbon steel or stainless steel. The minimum coating weights for zinc-coated steel must comply with ASTM A153.

- 5.18 Periodic special inspection must be provided in accordance with Section 4.4 in this report. Continuous special inspection for anchors installed in horizontal orientations to resist sustained tension loads must be provided in accordance with Section 4.4 of this report.
- 5.19 Installation of anchors in horizontal orientations to resist sustained tension loads shall be performed by personnel certified by an applicable certification program in accordance with ACI 318-14 17.8.2.2 or 17.8.2.3 or ACI 318-11 D.9.2.2 or D.9.2.3, as applicable. Overhead and upwardly inclined installation orientations are beyond the scope of this report.
- 5.20 Anchors shall not be used for applications where the in-service concrete temperature can vary from 40°F (5°C) or less to 80°F (27°C) or higher within a 12-hour period. Such applications may include but are not limited to anchorage of building facade systems and other applications subject to direct sun exposure.
- 5.21 FC10+ adhesive is manufactured, under a quality-control program with inspections by ICC-ES.

6.0 EVIDENCE SUBMITTED

Data in accordance with the ICC-ES Acceptance Criteria for Post-installed Adhesive Anchors in Concrete (AC308), dated January 2016, which incorporates requirements in ACI 355.4-11 for use in cracked and uncracked concrete; including, but not limited to, tests under freeze/thaw conditions, tests under sustained load, tests for installation direction, tests at elevated temperatures, tests for resistance to alkalinity, tests for resistance to sulfur and tests for seismic tension and shear.

7.0 IDENTIFICATION

- 7.1 FC10+ adhesive is identified by packaging labeled with the lot number; expiration date; company name; and the evaluation report number (ESR-3930). Threaded rods, nuts, washers, and deformed reinforcing bars are standard steel anchor elements and must conform to applicable national specifications as set forth in Tables 2 and 3 of this report or equivalent.
- 7.2 The report holder's contact information is the following:

FASTENAL COMPANY
2001 THEURER BOULEVARD
WINONA, MINNESOTA 55987
(507) 454-5374
www.fastenal.com

TABLE 1—DESIGN USE AND TABLE INDEX

DESIGN STRENGTH ¹		THREADED ROD (FRACTIONAL) ⁴		DEFORMED REINFORCING BAR ⁴			
Steel	N_{sa}, V_{sa}	Table 4		Table 5			
Concrete	$N_{cb}, N_{cbg}, V_{cb}, V_{cbg}, V_{cp}, V_{cpg}$	Table 6		Table 6			
Bond ²	N_b, N_{bg}	Table 7		Table 8			
CONCRETE TYPE	CONCRETE STATE	THREADED ROD DIAMETER (inch)	REINFORCING BAR SIZE (No.)	DRILLING METHOD	MINIMUM EMBEDMENT	MAXIMUM EMBEDMENT	SEISMIC DESIGN CATEGORIES ³
Normal-weight and lightweight	Cracked	$1/2, 5/8, 3/4, 7/8$ and 1	4, 5, 6, 7, 8	Hammer-drill	See Table 7 and Table 8	See Table 7 and Table 8	A through F
	Uncracked	$3/8, 1/2, 5/8, 3/4, 7/8$ and 1	3, 4, 5, 6, 7, 8	Hammer-drill	See Table 7 and Table 8	See Table 7 and Table 8	A and B

For **SI**: 1 inch = 25.4 mm. For **pound-inch** units: 1 mm = 0.03937 inch.

¹Reference ACI 318-14 17.3.1.1 or ACI 318-11 D.4.1.1, as applicable. The controlling strength is decisive from all appropriate failure modes (i.e. steel, concrete, bond) and design assumptions.

²See Section 4.1.4 of this report.

³See Section 4.1.11 for requirements for seismic design where applicable.

⁴Anchors with $1/2$ -, $5/8$ -, $3/4$ -, $7/8$ - and 1-inch-diameter (12.7, 15.9, 19.1, 22.2, 25.4 mm) threaded steel rods and No. 4 through No. 8 steel reinforcing bars may be installed in normal-weight concrete that is cracked or that may be expected to crack during the service life of the anchor when installed in hammer-drilled holes. Anchors with $3/8$ -inch-diameter (9.5 mm) threaded steel rods and No. 3 steel reinforcing bars are limited to installation in uncracked concrete when installed in hammer-drilled holes.

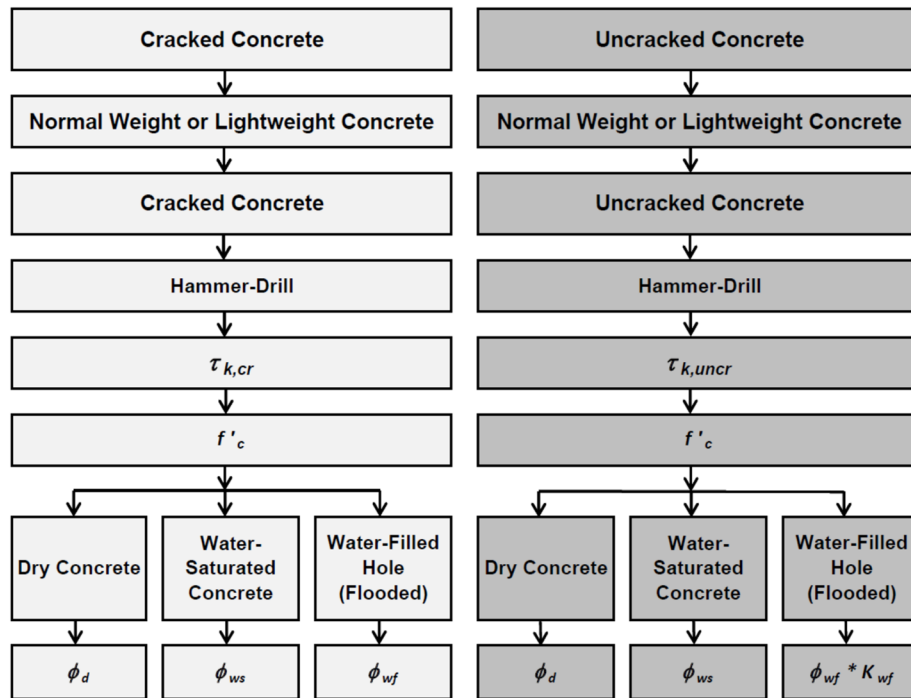

FIGURE 1—FLOW CHART FOR THE ESTABLISHMENT OF DESIGN BOND STRENGTH

TABLE 2—SPECIFICATIONS AND PHYSICAL PROPERTIES OF COMMON FRACTIONAL THREADED CARBON AND STAINLESS STEEL ROD MATERIALS¹

THREADED ROD SPECIFICATION	UNITS	MIN. SPECIFIED ULTIMATE STRENGTH, f_{uta}	MIN. SPECIFIED YIELD STRENGTH 0.2 PERCENT OFFSET, f_{ya}	$\frac{f_{uta}}{f_{ya}}$	ELONGATION MINIMUM PERCENT ⁸	REDUCTION OF AREA MINIMUM PERCENT	NUT SPECIFICATION ⁹	
Carbon Steel	ASTM A36 ² and F1554 ³ Grade 36	psi (MPa)	58,000 (400)	36,000 (248)	1.61	23	40 ¹⁰	ASTM A194 / A563 Grade A
	ASTM F1554 ³ Grade 105	psi (MPa)	125,000 (862)	105,000 (724)	1.19	15	45	ASTM A194 / A563 Grade DH
	ASTM A193 ⁴ Grade B7	psi (MPa)	125,000 (860)	105,000 (720)	1.19	16	50	
	ASTM A449 ⁵ (³ / ₈ to 1 inch dia.)	psi (MPa)	120,000 (828)	92,000 (635)	1.30	14	35	ASTM A194 / A563 Grade DH
	ASTM A449 ⁵ (1 ¹ / ₄ inch dia.)	psi (MPa)	105,000 (720)	81,000 (559)	1.30	14	35	
Stainless Steel (Types 304 and 316)	ASTM F593 ⁶ CW1 (³ / ₈ to ⁵ / ₈ inch dia.)	psi (MPa)	100,000 (690)	65,000 (450)	1.54	20	.. ¹¹	ASTM F594 Alloy Group 1, 2 or 3
	ASTM F593 ⁶ CW2 (³ / ₄ to 1 ¹ / ₄ inch dia.)	psi (MPa)	85,000 (590)	45,000 (310)	1.89	25	.. ¹¹	
	ASTM A193 ⁷ Grade B8/B8M, Class 1	psi (MPa)	75,000 (517)	30,000 (207)	2.50	30	50	ASTM F594 Alloy Group 1, 2 or 3
	ASTM A193 ⁷ Grade B8/B8M2, Class 2B	psi (MPa)	95,000 (655)	75,000 (517)	1.27	25	40	

For **SI**: 1 inch = 25.4 mm, 1 psi = 0.006897 MPa. For **pound-inch** units: 1 mm = 0.03937 inch, 1 MPa = 145.0 psi.

¹Adhesive must be used with continuously threaded carbon or stainless steels (all-thread) that have thread characteristics comparable with ANSI B1.1 UNC Coarse Thread Series. Tabulated values correspond to anchor diameters included in this report. See Section 3.2.4.3 of this report for ductility of steel anchor elements.

²Standard Specification for Carbon Structural Steel.

³Standard Specification for Anchor Bolts, Steel, 36, 55, and 105-ksi Yield Strength.

⁴Standard Specification for Alloy-Steel and Stainless Steel Bolting Materials for High Temperature or High Pressure Service and Other Special Purpose Applications.

⁵Standard Specification for Hex Cap Screws, Bolts and Studs, Steel, Heat Treated, 120/105/90 ksi Minimum Tensile Strength, General Use.

⁶Standard Specification for Stainless Steel Bolts, Hex Cap Screws, and Studs.

⁷Standard Standard Specification for Alloy-Steel and Stainless Steel Bolting for High Temperature or High Pressure Service and Other Special Purpose Applications.

⁸Based on 2-inch (50 mm) gauge length except ASTM A193, which are based on a gauge length of 4d.

⁹Nuts of other grades and style having specified proof load stress greater than the specified grade and style are also suitable. Nuts must have specified proof load stresses equal to or greater than the minimum tensile strength of the specified threaded rod. Material types of the nuts and washers must be matched to the threaded rods.

¹⁰Minimum percent reduction of area reported in ASTM A36 is 50 percent.

¹¹Minimum percent reduction of area not reported in the referenced ASTM standard.

TABLE 3—SPECIFICATIONS AND PHYSICAL PROPERTIES OF COMMON STEEL REINFORCING BARS¹

REINFORCING SPECIFICATION	UNITS	MINIMUM SPECIFIED ULTIMATE STRENGTH, f_{uta}	MINIMUM SPECIFIED YIELD STRENGTH, f_{ya}
ASTM A615 ² , A767 ⁴ , Grade 60	psi (MPa)	90,000 (620)	60,000 (414)
ASTM A706 ³ , A767 ⁴ , Grade 60	psi (MPa)	80,000 (550)	60,000 (414)
ASTM A615 ² , A767 ⁴ , Grade 40	psi (MPa)	60,000 (415)	40,000 (275)

For **SI**: 1 psi = 0.006897 MPa. For **pound-inch** units: 1 MPa = 145.0 psi.

¹Adhesive must be used with specified deformed reinforcing bars. Tabulated values correspond to bar sizes included in this report.

²Standard Specification for Deformed and Plain Carbon-Steel Bars for Concrete Reinforcement. Grade 60 and Grade 40 bars may be considered ductile elements. In accordance with ACI 318-14 17.2.3.4.3(a)vi or ACI 318-11 D.3.3.4.3(a)6, as applicable, deformed reinforcing bars meeting this specification used as ductile steel elements to resist earthquake effects shall be limited to reinforcing bars satisfying the requirements of 21.1.5.2(a) and (b).

³Standard Specification for Low-Alloy Steel Deformed and Plain Bars for Concrete Reinforcement. Bars furnished to specification are considered ductile elements.

⁴Standard Specification for Zinc-Coated (Galvanized) Steel Bars for Concrete Reinforcement. Bars furnished to specification are considered brittle elements unless evidence is otherwise shown to the satisfaction of the registered design professional and code official in accordance with Section 3.2.4.3 of this report.

TABLE 4—STEEL DESIGN INFORMATION FOR FRACTIONAL THREADED ROD

DESIGN INFORMATION		SYMBOL	UNITS	NOMINAL ROD DIAMETER (inch) ¹					
				3/8	1/2	5/8	3/4	7/8	1
Threaded rod nominal outside diameter		<i>d</i>	inch (mm)	0.375 (9.5)	0.500 (12.7)	0.625 (15.9)	0.750 (19.1)	0.875 (22.2)	1.000 (25.4)
Threaded rod effective cross-sectional area		<i>A_{se}</i>	inch ² (mm ²)	0.0775 (50)	0.1419 (92)	0.2260 (146)	0.3345 (216)	0.4617 (298)	0.6057 (391)
ASTM A36 and F1554, Grade 36	Nominal strength as governed by steel strength (for a single anchor)	<i>N_{sa}</i>	lbf (kN)	4,495 (20.0)	8,230 (36.6)	13,110 (58.3)	19,400 (86.3)	26,780 (119.1)	35,130 (156.3)
		<i>V_{sa}</i>	lbf (kN)	2,695 (12.0)	4,940 (22.0)	7,860 (35.0)	11,640 (51.8)	16,070 (71.4)	21,080 (93.8)
	Reduction factor for seismic shear	$\alpha_{V,seis}$	-	Not applicable	0.85	0.85	0.85	0.85	0.80
	Strength reduction factor for tension ²	ϕ	-	0.75					
	Strength reduction factor for shear ²	ϕ	-	0.65					
ASTM A193 Grade B7 and F1554, Grade 105	Nominal strength as governed by steel strength (for a single anchor)	<i>N_{sa}</i>	lbf (kN)	9,685 (43.1)	17,735 (78.9)	28,250 (125.7)	41,810 (186.0)	57,710 (256.7)	75,710 (336.8)
		<i>V_{sa}</i>	lbf (kN)	5,815 (25.9)	10,640 (47.3)	16,950 (75.4)	25,085 (111.6)	34,625 (154.0)	45,425 (202.1)
	Reduction factor for seismic shear	$\alpha_{V,seis}$	-	Not applicable	0.85	0.85	0.85	0.85	0.80
	Strength reduction factor for tension ²	ϕ	-	0.75					
	Strength reduction factor for shear ²	ϕ	-	0.65					
ASTM A449	Nominal strength as governed by steel strength (for a single anchor)	<i>N_{sa}</i>	lbf (kN)	9,300 (41.4)	17,025 (75.7)	27,120 (120.6)	40,140 (178.5)	55,905 (248.7)	63,600 (282.9)
		<i>V_{sa}</i>	lbf (kN)	5,580 (24.8)	10,215 (45.4)	16,270 (72.4)	24,085 (107.1)	33,540 (149.2)	38,160 (169.7)
	Reduction factor for seismic shear	$\alpha_{V,seis}$	-	Not applicable	0.80	0.80	0.80	0.80	0.80
	Strength reduction factor for tension ²	ϕ	-	0.75					
	Strength reduction factor for shear ²	ϕ	-	0.65					
ASTM F593 CW Stainless (Types 304 and 316)	Nominal strength as governed by steel strength (for a single anchor)	<i>N_{sa}</i>	lbf (kN)	7,750 (34.5)	14,190 (63.1)	22,600 (100.5)	28,430 (126.5)	39,245 (174.6)	51,485 (229.0)
		<i>V_{sa}</i>	lbf (kN)	4,650 (20.7)	8,515 (37.9)	13,560 (60.3)	17,060 (75.9)	23,545 (104.7)	30,890 (137.4)
	Reduction factor for seismic shear	$\alpha_{V,seis}$	-	Not applicable	0.85	0.85	0.85	0.85	0.80
	Strength reduction factor for tension ³	ϕ	-	0.65					
	Strength reduction factor for shear ³	ϕ	-	0.60					
ASTM A193 Grade B8/B8M, Class 1 Stainless (Types 304 and 316)	Nominal strength as governed by steel strength (for a single anchor) ⁴	<i>N_{sa}</i>	lbf (kN)	4,420 (19.7)	8,090 (36.0)	12,880 (57.3)	19,065 (84.8)	26,315 (117.1)	34,525 (153.6)
		<i>V_{sa}</i>	lbf (kN)	2,650 (11.8)	4,855 (21.6)	7,730 (34.4)	11,440 (50.9)	15,790 (70.2)	20,715 (92.1)
	Reduction factor for seismic shear	$\alpha_{V,seis}$	-	Not applicable	0.85	0.85	0.85	0.85	0.80
	Strength reduction factor for tension ²	ϕ	-	0.75					
	Strength reduction factor for shear ²	ϕ	-	0.65					
ASTM A193 Grade B8/B8M2, Class 2B Stainless (Types 304 and 316)	Nominal strength as governed by steel strength (for a single anchor)	<i>N_{sa}</i>	lbf (kN)	7,365 (32.8)	13,480 (60.0)	21,470 (95.5)	31,775 (141.3)	43,860 (195.1)	57,545 (256.0)
		<i>V_{sa}</i>	lbf (kN)	4,470 (19.7)	8,085 (36.0)	12,880 (57.3)	19,065 (84.8)	26,315 (117.1)	34,525 (153.6)
	Reduction factor for seismic shear	$\alpha_{V,seis}$	-	Not applicable	0.85	0.85	0.85	0.85	0.80
	Strength reduction factor for tension ²	ϕ	-	0.75					
	Strength reduction factor for shear ²	ϕ	-	0.65					

For **SI**: 1 inch = 25.4 mm, 1 lbf = 4.448 N. For **pound-inch** units: 1 mm = 0.03937 inches, 1 N = 0.2248 lbf.

¹Values provided for reinforcing bar material types based on minimum specified strengths and calculated in accordance with ACI 318-14 Eq. 17.4.1.2 and Eq. 17.5.1.2b or ACI 318-11 Eq. D-2 and Eq. D-29, as applicable. Nuts must be appropriate for the rod, as listed in Table 2 of this report.

²The tabulated value of ϕ applies when the load combinations of Section 1605.2 of the IBC, ACI 318-14 5.3 or ACI 318-11 9.2, as applicable are used in accordance with ACI 318-14 17.3.3 or ACI 318-11 D.4.3, as applicable. If the load combinations of ACI 318-11 Appendix C are used, the appropriate value of ϕ must be determined in accordance with ACI 318-11 D.4.4. Values correspond to ductile steel elements.

³The tabulated value of ϕ applies when the load combinations of Section 1605.2 of the IBC, ACI 318-14 5.3 or ACI 318-11 9.2, as applicable are used in accordance with ACI 318-14 17.3.3 or ACI 318-11 D.4.3, as applicable. If the load combinations of ACI 318-11 Appendix C are used, the appropriate value of ϕ must be determined in accordance with ACI 318-11 D.4.4. Values correspond to brittle steel elements.

⁴In accordance with ACI 318-14 26.12.3.1(a) and 26.11.1.2(c) or ACI 318-11 D.5.1.2 and D.6.1.2, as applicable the calculated values for nominal tension and shear strength for ASTM A193 Grade B8/B8M Class 1 stainless steel threaded rods are based on limiting the specified tensile strength of the anchor steel to 1.9 f_y or 57,000 psi (393 MPa).

TABLE 5—STEEL DESIGN INFORMATION FOR REINFORCING BARS

DESIGN INFORMATION		SYMBOL	UNITS	NOMINAL REINFORCING BAR SIZE (REBAR) ¹							
				No. 3	No. 4	No. 5	No. 6	No. 7	No. 8		
Rebar nominal outside diameter		<i>d</i>	inch (mm)	0.375 (9.5)	0.500 (12.7)	0.625 (15.9)	0.750 (19.1)	0.875 (22.2)	1.000 (25.4)		
Rebar effective cross-sectional area		<i>A_{se}</i>	inch ² (mm ²)	0.110 (71)	0.200 (129)	0.310 (200)	0.440 (284)	0.600 (387)	0.790 (510)		
ASTM A615, Grade 60	Nominal strength as governed by steel strength (for a single anchor)	<i>N_{sa}</i>	lbf (kN)	9,900 (44.0)	18,000 (80.1)	27,900 (124.1)	39,600 (176.1)	54,000 (240.2)	71,100 (316.3)		
		<i>V_{sa}</i>	lbf (kN)	5,940 (26.4)	10,800 (48.0)	16,740 (74.5)	23,760 (105.7)	32,400 (144.1)	42,660 (189.8)		
	Reduction factor for seismic shear	<i>α_{V,seis}</i>	-	Not applicable	0.70	0.70	0.70	0.70	0.70		
	Strength reduction factor for tension ²	<i>φ</i>	-	0.75							
	Strength reduction factor for shear ²	<i>φ</i>	-	0.65							
ASTM A706, Grade 60	Nominal strength as governed by steel strength (for a single anchor)	<i>N_{sa}</i>	lbf (kN)	8,800 (39.1)	16,000 (71.2)	24,800 (110.3)	35,200 (156.6)	48,000 (213.5)	63,200 (281.1)		
		<i>V_{sa}</i>	lbf (kN)	5,280 (23.5)	9,600 (42.7)	14,880 (66.2)	21,120 (94.0)	28,800 (128.1)	37,920 (168.7)		
	Reduction factor for seismic shear	<i>α_{V,seis}</i>	-	Not applicable	0.70	0.70	0.70	0.70	0.70		
	Strength reduction factor for tension ²	<i>φ</i>	-	0.75							
	Strength reduction factor for shear ²	<i>φ</i>	-	0.65							
ASTM A615, Grade 40	Nominal strength as governed by steel strength (for a single anchor)	<i>N_{sa}</i>	lbf (kN)	6,600 (29.4)	12,000 (53.4)	18,600 (82.7)	26,400 (117.4)	In accordance with ASTM A615, Grade 40 bars are furnished only in sizes No. 3 through No. 6			
		<i>V_{sa}</i>	lbf (kN)	3,960 (17.6)	7,200 (32.0)	11,160 (49.6)	15,840 (70.5)				
	Reduction factor for seismic shear	<i>α_{V,seis}</i>	-	Not applicable	0.70	0.70	0.70				
	Strength reduction factor for tension ²	<i>φ</i>	-	0.75							
	Strength reduction factor for shear ²	<i>φ</i>	-	0.65							

For **SI**: 1 inch = 25.4 mm, 1 lbf = 4.448 N. For **pound-inch** units: 1 mm = 0.03937 inches, 1 N = 0.2248 lbf.

¹Values provided for reinforcing bar material types based on minimum specified strengths and calculated in accordance with ACI 318-14 Eq. 17.4.1.2 and Eq. 17.5.1.2b or ACI 318-11 Eq. D-2) and Eq. D-29, as applicable.

²The tabulated value of *φ* applies when the load combinations of Section 1605.2 of the IBC, ACI 318-14 5.3 or ACI 318-11 Section 9.2 are used in accordance with ACI 318-14 17.3.3 or ACI 318-11 D.4.3, as applicable. If the load combinations of ACI 318-11 Appendix C are used, the appropriate value of *φ* must be determined in accordance with ACI 318 D.4.4. Values correspond to ductile steel elements. In accordance with ACI 318-14 17.2.3.4.3(a)6 or ACI 318-11 D.3.3.4.3 (a) 6, as applicable, deformed reinforcing bars meeting this specification used as ductile steel elements to resist earthquake effects shall be limited to reinforcing bars satisfying the requirements of ACI 318-14 20.2.2.4 and 20.2.2.5 or ACI 318-11 21.1.5.2 (a) and (b) as applicable.

³The tabulated value of *φ* applies when the load combinations of Section 1605.2 of the IBC, ACI 318-14 5.3 or ACI 318-11 9.2 are used in accordance with ACI 318-14 17.3.3 or ACI 318-11 D.4.3, as applicable. If the load combinations of ACI 318-11 Appendix C are used, the appropriate value of *φ* must be determined in accordance with ACI 318-11 D.4.4. Values correspond to brittle steel elements.

TABLE 6—CONCRETE BREAKOUT AND PRYOUT DESIGN INFORMATION FOR FRACTIONAL THREADED ROD AND REINFORCING BARS IN HOLES DRILLED WITH A HAMMER DRILL AND CARBIDE BIT¹

DESIGN INFORMATION	SYMBOL	UNITS	NOMINAL ROD DIAMETER (inch) / REINFORCING BAR SIZE					
			³ / ₈ or #3	¹ / ₂ or #4	⁵ / ₈ or #5	³ / ₄ or #6	⁷ / ₈ or #7	1 or #8
Effectiveness factor for cracked concrete	<i>k_{c,cr}</i>	- (SI)	Not Applicable			17 (7.1)		
Effectiveness factor for uncracked concrete	<i>k_{c,uncr}</i>	- (SI)	24 (10.0)					
Minimum embedment	<i>h_{ef,min}</i>	inch (mm)	2 ³ / ₈ (60)	2 ³ / ₄ (70)	3 ¹ / ₈ (79)	3 ¹ / ₂ (89)	3 ¹ / ₂ (89)	4 (102)
Maximum embedment	<i>h_{ef,max}</i>	inch (mm)	4 ¹ / ₂ (114)	6 (152)	7 ¹ / ₂ (191)	9 (229)	10 ¹ / ₂ (267)	12 (305)
Minimum anchor spacing	<i>s_{min}</i>	inch (mm)	1 ⁷ / ₈ (48)	2 ¹ / ₂ (64)	3 ¹ / ₈ (79)	3 ³ / ₄ (95)	4 ³ / ₈ (111)	5 (127)
Minimum edge distance	<i>c_{min}</i>	inch (mm)	5 <i>d</i> where <i>d</i> is nominal outside diameter of the anchor; see Section 4.1.9 of this report for design with reduced minimum edge distances (with reduced torque)					
Minimum member thickness	<i>h_{min}</i>	inch (mm)	<i>h_{ef}</i> + 1 ¹ / ₄ (<i>h_{ef}</i> + 30)		<i>h_{ef}</i> + 2 <i>d_o</i> where <i>d_o</i> is hole diameter; for installation parameters see Table 9 of this report			
Critical edge distance—splitting (for uncracked concrete only)	<i>c_{ac}</i>	inch (mm)	See Section 4.1.10 of this report					
Strength reduction factor for tension, concrete failure modes, Condition B ²	<i>φ</i>	-	0.65					
Strength reduction factor for shear, concrete failure modes, Condition B ²	<i>φ</i>	-	0.70					

For **SI**: 1 inch = 25.4 mm, 1 lbf = 4.448 N. For **pound-inch** units: 1 mm = 0.03937 inch, 1 N = 0.2248 lbf.

¹Additional setting information is described in the installation instructions, Figure 4 of this report.

²Condition A requires supplemental reinforcement, while Condition B applies where supplemental reinforcement is not provided or where pryout governs, as set forth in ACI 318-14 17.3.3 or ACI 318-11 D.4.3, as applicable. The tabulated value of *φ* applies when the load combinations of Section 1605.2 of the IBC, ACI 318-14 5.3 or ACI 318-11 9.2 are used in accordance with ACI 318-14 17.3.3 or ACI 318-11 D.4.3, as applicable. If the load combinations of ACI 318-11 Appendix C are used, the appropriate value of *φ* must be determined in accordance with ACI 318-11 D.4.4.

TABLE 7—BOND STRENGTH DESIGN INFORMATION FOR FRACTIONAL THREADED RODS IN HOLES DRILLED WITH A HAMMER DRILL AND CARBIDE BIT¹

DESIGN INFORMATION		SYMBOL	UNITS	NOMINAL ROD DIAMETER (inch)					
				3/8	1/2	5/8	3/4	7/8	1
Minimum embedment		$h_{ef,min}$	inch (mm)	2 ³ / ₈ (60)	2 ³ / ₄ (70)	3 ¹ / ₈ (79)	3 ¹ / ₂ (89)	3 ¹ / ₂ (89)	4 (102)
Maximum embedment		$h_{ef,max}$	inch (mm)	4 ¹ / ₂ (114)	6 (152)	7 ¹ / ₂ (191)	9 (229)	10 ¹ / ₂ (267)	12 (305)
122°F (50°C) Maximum long-term service temperature; 176°F (80°C) maximum short-term service temperature^{2,3}	Characteristic bond strength in cracked concrete ^{4,6}	$\tau_{k,cr}$	psi (N/mm ²)	Not applicable	458 (3.2)	472 (3.3)	467 (3.2)	467 (3.2)	472 (3.3)
	Characteristic bond strength in cracked concrete, short-term loads only ⁶	$\tau_{k,cr}$	psi (N/mm ²)	Not applicable	655 (4.5)	675 (4.7)	668 (4.6)	668 (4.6)	675 (4.7)
	Characteristic bond strength in uncracked concrete ^{4,7}	$\tau_{k,uncr}$	psi (N/mm ²)	765 (5.3)	757 (5.2)	749 (5.2)	741 (5.1)	741 (5.1)	676 (4.7) Not applicable in water-filled hole installation condition
	Characteristic bond strength in uncracked concrete, short-term loads only ⁷	$\tau_{k,uncr}$	psi (N/mm ²)	1,095 (7.5)	1,083 (7.5)	1,071 (7.4)	1,059 (7.3)	1,059 (7.3)	967 (6.7) Not applicable in water-filled hole installation condition
Permissible installation conditions ⁵	Dry concrete	ϕ_d	-	0.65				0.65	0.65
	Water-saturated concrete	ϕ_{ws}	-	0.55				0.55	0.55
	Water-filled hole (flooded)	ϕ_{wf}	-	0.45				0.45	0.45
		K_{wf}	-	0.78				0.70	0.69
Reduction factor for seismic tension		$\alpha_{N,seis}$	-	0.95					

For **SI**: 1 inch = 25.4 mm, 1 psi = 0.006894 MPa. For **pound-inch** units: 1 mm = 0.03937 inch, 1 MPa = 145.0 psi.

¹Bond strength values correspond to concrete compressive strength $f_c = 2,500$ psi. For concrete compressive strength, f_c between 2,500 psi and 8,000 psi, the tabulated characteristic bond strength may be increased by a factor of $(f_c / 2,500)^{0.1}$ [For **SI**: $(f_c / 17.2)^{0.1}$]. See Section 4.1.4 of this report.

²Long-term and short-term temperatures meet and exceed the requirements of Section 8.5 of ACI 355.4 and Table 9.1, Temperature Category A.

³Short-term elevated concrete temperatures are those that occur over brief intervals, e.g. as a result of diurnal cycling. Long-term concrete temperatures are roughly constant over significant periods of time.

⁴Characteristic bond strengths are for sustained loads including dead and live loads.

⁵Permissible installation conditions include dry concrete, water-saturated concrete and water-filled holes. Water-filled holes include applications in dry or water-saturated concrete where the drilled holes contain standing water at the time of anchor installation. For installation instructions see Figure 3 of this report.

⁶For structures assigned to Seismic Design Categories C, D, E or F, bond strength values for cracked concrete must be adjusted by an additional reduction factor, $\alpha_{N,seis}$, as given in the table. See Section 4.1.11 of this report.

⁷Bond strength values for uncracked concrete are applicable for structures assigned to Seismic Design Categories A and B only.

**TABLE 8—BOND STRENGTH DESIGN INFORMATION FOR REINFORCING BARS
IN HOLES DRILLED WITH A HAMMER DRILL AND CARBIDE BIT¹**

DESIGN INFORMATION		SYMBOL	UNITS	REINFORCING BAR SIZE					
				#3	#4	#5	#6	#7	#8
Minimum embedment		$h_{ef,min}$	inch (mm)	2 ³ / ₈ (60)	2 ³ / ₄ (70)	3 ¹ / ₈ (79)	3 ¹ / ₂ (89)	3 ¹ / ₂ (89)	4 (102)
Maximum embedment		$h_{ef,max}$	inch (mm)	4 ¹ / ₂ (114)	6 (152)	7 ¹ / ₂ (191)	9 (229)	10 ¹ / ₂ (267)	12 (305)
122°F (50°C) Maximum long-term service temperature; 176°F (80°C) maximum short-term service temperature ^{2,3}	Characteristic bond strength in cracked concrete ^{4,6}	$\tau_{k,cr}$	psi (N/mm ²)	Not applicable	305 (2.1)	314 (2.2)	311 (2.1)	311 (2.1)	314 (2.2)
	Characteristic bond strength in cracked concrete, short-term loads only ⁶	$\tau_{k,cr}$	psi (N/mm ²)	Not applicable	435 (3.0)	449 (3.1)	444 (3.1)	444 (3.1)	449 (3.1)
	Characteristic bond strength in uncracked concrete ^{4,7}	$\tau_{k,uncr}$	psi (N/mm ²)	765 (5.3)	757 (5.2)	749 (5.2)	741 (5.1)	741 (5.1)	676 (4.7) Not applicable in water-filled hole installation condition
	Characteristic bond strength in uncracked concrete, short-term loads only ⁷	$\tau_{k,uncr}$	psi (N/mm ²)	1,095 (7.5)	1,083 (7.5)	1,071 (7.4)	1,059 (7.3)	1,059 (7.3)	967 (6.7) Not applicable in water-filled hole installation condition
Permissible installation conditions ⁵	Dry concrete	ϕ_d	-	0.65				0.65	0.65
	Water-saturated concrete	ϕ_{ws}	-	0.55				0.55	0.55
	Water-filled hole (flooded)	ϕ_{wf}	-	0.45				0.45	0.45
		k_{wf}	-	0.78				0.70	0.69
Reduction factor for seismic tension		$\alpha_{N,seis}$	-	1.0					

For **SI**: 1 inch = 25.4 mm, 1 psi = 0.006894 MPa. For **pound-inch** units: 1 mm = 0.03937 inch, 1 MPa = 145.0 psi.

¹Bond strength values correspond to concrete compressive strength $f'_c = 2,500$ psi. For concrete compressive strength, f'_c between 2,500 psi and 8,000 psi, the tabulated characteristic bond strength may be increased by a factor of $(f'_c / 2,500)^{0.1}$ [For **SI**: $(f'_c / 17.2)^{0.1}$]. See Section 4.1.4 of this report.

²Long-term and short-term temperatures meet and exceed the requirements of Section 8.5 of ACI 355.4 and Table 9.1, Temperature Category A.

³Short-term elevated concrete temperatures are those that occur over brief intervals, e.g. as a result of diurnal cycling. Long-term concrete temperatures are roughly constant over significant periods of time.

⁴Characteristic bond strengths are for sustained loads including dead and live loads.

⁵Permissible installation conditions include dry concrete, water-saturated concrete and water-filled holes. Water-filled holes include applications in dry or water-saturated concrete where the drilled holes contain standing water at the time of anchor installation. For installation instructions see Figure 3 of this report.

⁶For structures assigned to Seismic Design Categories C, D, E or F, the tabulated bond strength values for cracked concrete do not require an additional reduction factor applied for seismic tension ($\alpha_{N,seis} = 1.0$), where seismic design is applicable. See Section 4.1.11 of this report for requirements for seismic design.

⁷Bond strength values for uncracked concrete are applicable for structures assigned to Seismic Design Categories A and B only.

TABLE 9—INSTALLATION PARAMETERS FOR FRACTIONAL THREADED ROD AND REINFORCING BARS

PARAMETER	SYMBOL	UNITS	NOMINAL ROD DIAMETER (inch) / REINFORCING BAR SIZE							
			³ / ₈ or #3	1/2	#4	⁵ / ₈ or #5	³ / ₄ or #6	⁷ / ₈ or #7	1 or #8	
Threaded rod outside diameter	<i>d</i>	inch (mm)	0.375 (9.5)	0.500 (12.7)	0.625 (15.9)	0.750 (19.1)	0.875 (22.2)	1.000 (25.4)		
Rebar nominal outside diameter	<i>d</i>	inch (mm)	0.375 (9.5)	0.500 (12.7)	0.625 (15.9)	0.750 (19.1)	0.875 (22.2)	1.000 (25.4)		
Carbide drill bit nominal size	<i>d_o (d_{bit})</i>	inch	⁷ / ₁₆	⁹ / ₁₆	⁵ / ₈	¹¹ / ₁₆ or ³ / ₄	⁷ / ₈	1	¹ / ₈	
Minimum embedment	<i>h_{ef,min}</i>	inch (mm)	2 ³ / ₈ (60)	2 ³ / ₄ (70)	3 ¹ / ₈ (79)	3 ¹ / ₂ (89)	3 ¹ / ₂ (89)	4 (102)		
Maximum embedment	<i>h_{ef,max}</i>	inch (mm)	4 ¹ / ₂ (114)	6 (152)	7 ¹ / ₂ (191)	9 (229)	10 ¹ / ₂ (267)	12 (305)		
Max. rod torque	<i>T_{max}</i>	ft-lbs	15	33	60	105	125	165		
Max. torque ² (A36/Grade 36 rod)	<i>T_{max}</i>	ft-lbs	10	25	50	90	125	165		
Max. torque ³ (Class 1 SS rod)	<i>T_{max}</i>	ft-lbs	5	20	40	60	100	165		
Minimum anchor spacing	<i>S_{min}</i>	inch (mm)	1 ⁷ / ₈ (48)	2 ¹ / ₂ (64)	3 ¹ / ₈ (79)	3 ³ / ₄ (95)	4 ³ / ₈ (111)	5 (127)		
Minimum edge distance	<i>C_{min}</i>	inch (mm)	5 <i>d</i> ; or see Section 4.1.9 of this report for installation parameters with reduced minimum edge distances (with reduced torque)							
Minimum member thickness	<i>h_{min}</i>	inch (mm)	<i>h_{ef}</i> + 1 ¹ / ₄ (<i>h_{ef}</i> + 30)			<i>h_{ef}</i> + 2 <i>d_o</i>				

For SI: 1 inch = 25.4 mm, 1 ft-lbf = 1.356 N-m. For pound-inch units: 1 mm = 0.03937 inch, 1 N-m = 0.7375 ft-lbf.

¹N/A = Not Applicable.

²These values apply to ASTM A36 / F1554 Grade 36 carbon steel threaded rods.

³These values apply to ASTM A193 Grade B8/B8M (Class 1) stainless steel threaded rods.

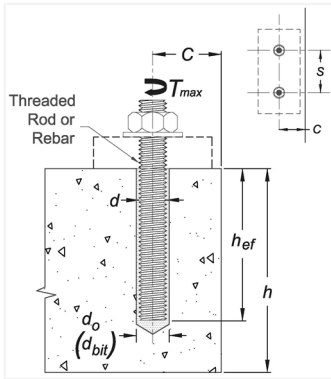

FIGURE 2—FC10+ ADHESIVE ANCHOR SYSTEM INCLUDING TYPICAL STEEL ANCHOR ELEMENTS



FC10+ Instruction Card

FC10+ is an easy dispensing, rapid-curing, high strength anchoring adhesive which is formulated for use by trained professionals. Please refer to Fastenal installation instructions and SDS for additional detailed information.

PRECAUTION: Safety glasses and dust masks should be used when drilling holes into concrete, stone and masonry. Wear gloves and safety glasses when handling and dispensing adhesive. Do not sand the adhesive and create silica dust which could be inhaled. Avoid skin and eye contact. Use a NIOSH-approved chemical mask to avoid respiratory discomfort if working indoors or in a confined area, or if sensitive to adhesive odors. Wash hands or other affected body parts with soap and water if skin contact occurs. Flush eyes with plenty of water and seek immediate medical attention if eye contact occurs. Move to fresh air if adhesive odor begins to cause discomfort.

IMPORTANT! Before using, read and review Safety Data Sheet (SDS). This product contains crystalline silica and as supplied does not pose a dust hazard. IARC classifies crystalline silica (quartz sand) as a Group 1 carcinogen based upon evidence among workers in industries where there has been long-term and chronic exposure (via inhalation) to silica dust, e.g. mining, quarry, stone crushing, refractory brick and pottery workers. This product does not pose a dust hazard; therefore, this classification is not relevant. However, if re-used (fully cured) product is further processed (e.g. sanded, drilled) be sure to wear proper respiratory and eye protection to avoid health risk.

HANDLING AND STORAGE: Store in a cool, dry, well ventilated area at temperatures between 32°F (0°C) and 86°F (30°C). Keep away from excessive heat and flame. Keep partially used containers closed when not in use. Protect from damage. Store away from heat and light.

Be sure to use expiration date on product label. **DO NOT USE EXPIRED PRODUCT.** Partially used cartridges may be stored with hardened adhesive in the attached mixing nozzle. Note: If the cartridge is reused, attach a new mixing nozzle and discard the initial quantity of the anchor adhesive as described in the setting instructions (Steps #3 and #5).

Distributed by Fastenal Company
 USA: Winona, MN 55987
 Canada: 300 Vabnamki Drive, Kitchener, ON N2C 0B7
 (507) 454-5374 www.fastenal.com

[V.] Adhesive piston plugs

Threaded rod diameter (in.)	Rebar size (in.)	Drill bit diameter (in.)	Plug size	Plastic Plug (Cat. #)	Horizontal installations ^{1,2}
1/2	#4	9/16	9/16	115-62809	
5/8	#5	11/16	11/16	115-62810	
3/4	#6	7/8	7/8	115-62811	
7/8	#7	1	1	115-62813	
1	#8	1-1/8	1-1/8	115-62814	

1. A plastic extension tube (Part #11562807) or equivalent approved by Fastenal must be used with piston plugs.
 2. All fixed horizontal installations with embedments greater than 8 inches require piston plugs.

[I.] Hole cleaning tools - wire brushes and air blowers

Fractional anchor sizes

Threaded rod diameter (in.)	Rebar size (in.)	Hammer-drill bit size (in.)	Min. brush diameter (in.)	Brush length (in.)	Steel wire (Part #)	AIR BLOWERS
3/8	#3	7/16	0.475	6-3/4	0239952	Hand pump (volume 25.11 oz Gal. # 0239953 or compressed air nozzle (min. 50 psi)
1/2	-	9/16	0.600	6-3/4	0239953	Hand Pump Part # 0239953
-	#4	5/8	0.670	6-3/4	0239953	Hand Pump Part # 0239953
5/8	#5	11/16 or 3/4	0.735	7-7/8	0239954	
3/4	#6	7/8	0.790	7-7/8	0239954	
7/8	#7	1	0.920	7-7/8	0239955	
1	#8	1-1/8	1.045	11-7/8	0239956	

A brush extension (Part #0239957) must be used with a steel wire brush for holes drilled deeper than the listed brush length.

1. For installations with 5/8-inch threaded rod and #5 rebar size, the preferred ANSI drill bit diameter is 3/4-inch. If an 11/16-inch ANSI drill bit is used the user must check before opening the adhesive to verify that the steel anchor element can be inserted into the cleaned hole without resistance.

[II.] Gel (working) times and curing times

Temperature of Base Material	Gel (working) time	Full curing time
14 F -10 C	90 min.	24 hr.
23 F -5 C	90 min.	14 hr.
32 F 0 C	45 min.	7 hr.
41 F 5 C	25 min.	2 hr.
68 F 20 C	6 min.	45 min.
88 F 30 C	4 min.	25 min.
104 F 40 C	1.5 min.	15 min.

Usage information for intermediate base materials: Temperature is as possible. For installations in base material temperature must be conditioned to between 88 F and 95 F (30 C and 35 C).

[III.] Installation parameters - Specifications for installation of threaded rods and reinforcing bars

Anchor property / Setting information	Threaded rod (in.) / reinforcing bar size (in.)			
	#4	#5 or #6	#7 or #8	#9 or #10
d = Nominal anchor rod diameter (in.)	0.375	0.625	0.750	0.875
d = Nominal rebar diameter (in.)	0.375	0.500	0.625	0.875
d _(drill) = Nominal ANSI drill bit size (in.)	7/16	9/16	11/16 or 3/4	7/8
h _{min} = Minimum embedment (inches)	2-3/8	2-3/4	3-1/8	3-1/2
h _{max} = Maximum embedment (inches)	4-1/2	6	7-1/2	10-1/2
S _{min} = Minimum spacing (inches)	1-7/8	2-1/2	3-1/8	4-3/8
c _{min} = Minimum edge distance (inches)	1-3/4	1-3/4	1-3/4	1-3/4
h _{min} = Minimum member thickness (inches)	h _{min} + 1-1/4			
T _{max} = Maximum rod torque (ft.-lb.)	15	33	80	105
T _{max} = Maximum torque (ft.-lb.) for A307 carbon steel rod	10	25	50	90
T _{max} = Maximum torque (ft.-lb.) for Grade B6 / B8M Class 1 rod	5	20	40	80

For installations between the minimum edge distance and 5d, the tabular maximum torque must be reduced (multiplied) by a factor of 0.45.

[IV.] FC10+ adhesive anchor system selection table

Injection tool	FC10+ adhesive anchor system	Extra mixing nozzle
10 fl. oz. manual dispensers (caulking gun)	Part #0217497 - Standard all-metal	Mixing nozzle and extension tube Part #11562804
28 fl. oz. manual dispenser	Part #11562808 - Manual high performance all-metal	Long mixing nozzle w/ extension tube Part #11562805

A plastic extension tube (Part #11562807) or equivalent approved by Fastenal must be used for embedment depths greater than 7-1/2".

FIGURE 3—MANUFACTURER'S PUBLISHED INSTALLATION INSTRUCTIONS (MPII)

Fastenal FC10+ Instruction Card

Installation instructions for solid base material – For any application not covered by this document please contact Fastenal (www.fastenal.com)

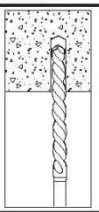
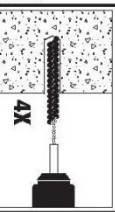
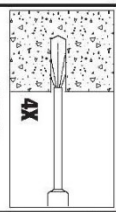
SELECT HAMMER DRILLING AS SUITABLE FOR APPLICATION	
 <p>1. Drill a hole into the base material with rotary hammer drill to the size and embedment required by the selected steel hardware element (see Table II). Tolerances of carbide drill bits must meet ANSI Standard B21.2.15.</p>	<p>Hammer Drilling</p> <p>⚠️ Caution: Wear suitable eye and skin protection. Avoid inhalation of dusts during drilling and/or removal.</p> <p>Note: In case of standing water in the drilled bore hole (flooded hole), all the water has to be removed from the hole (e.g. vacuum, compressed air, etc.) prior to cleaning.</p>
 <p>2a. Starting from the bottom or back of the anchor hole, blow the hole clean a minimum of four times (4x).</p> <p>2b. Determine the brush diameter (see Table I) for the drilled hole and attach the brush with adaptor to a rotary drill tool or battery screw gun. Brush the hole with the selected wire brush a minimum of four times (4x).</p>	<p>Hole Cleaning</p> <p>2c. Repeat Step 2a again: Starting from the bottom or back of the anchor hole, blow the hole clean a minimum of four times (4x).</p>
 <p>2c. Repeat Step 2a again: Starting from the bottom or back of the anchor hole, blow the hole clean a minimum of four times (4x).</p>	<p>3. Check adhesive expiration date on cartridge label. Do not use expired product. Review Safety Data Sheet (SDS) before use. Cartridge temperature must be between 23°F - 104°F (-5°C - 40°C) when in use except as noted in Table II.</p> <p>Attach a supplied mixing nozzle to the cartridge. Do not modify the mixer in any way and make sure the mixing element is inside the nozzle. Load the cartridge into the correct dispensing tool.</p>

Follow steps #1 through #10 for recommended installation

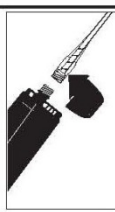
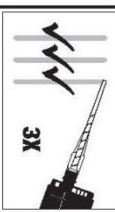
PREPARATION	
 <p>4. Prior to inserting the anchor rod or rebar into the filled bore hole, the position of the embedment depth has to be marked on the anchor. Verify anchor element is straight and free of surface damage.</p> <p>5. Adhesive must be properly mixed to achieve published properties. Prior to dispensing adhesive into the drilled hole, separately dispense at least three full strokes of adhesive through the mixing nozzle until the adhesive is a consistent gray color.</p>	<p>6. Fill the cleaned hole approximately two-thirds full with mixed adhesive starting from the bottom or back of the anchor hole. Slowly withdraw the mixing nozzle as the hole fills to avoid creating air pockets or voids. For embedment depths greater than 7-1/2" an extension tube must be used with the mixing nozzle (see Table VI).</p>
 <p>7. The anchor should be free of dirt, grease, oil or other foreign material. Push clean threaded rod or reinforcing bar into the anchor hole while turning slightly to ensure positive distribution of the adhesive until the embedment depth is reached. Observe the gel (working) time.</p>	<p>8. Be sure that the anchor element is installed to the specified embedment depth. Adhesive must completely fill the annular gap at the concrete surface. Following installation of the anchor element, remove excess adhesive. Protect the anchor element threads from fouling with adhesive. For all installations the anchor element must be fully restrained from movement throughout the specified curing period, where necessary through the use of temporary wedges, external supports, or other methods. Minor adjustments to the position of the anchor element may be performed during the gel time only.</p>

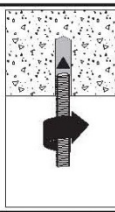
INSTALLATION, CONTINUED	
 <p>9. Allow the adhesive anchor to cure to the specified full curing time prior to applying any load (see Table II). Do not disturb, torque or load the anchor until it is fully cured.</p>	<p>10. After full curing of the adhesive anchor a fixture can be installed to the anchor and tightened up to the maximum torque (shown in Table II) by using a calibrated torque wrench. Take care not to exceed the maximum torque for the selected anchor.</p>

FIGURE 3—MANUFACTURER'S PUBLISHED INSTALLATION INSTRUCTIONS (MPII) (Continued)