

ICC-ES Evaluation Report

ESR-3912

Reissued October 2023

This report also contains:

- FBC Supplement

Subject to renewal October 2024

- LABC Supplement

ICC-ES Evaluation Reports are not to be construed as representing aesthetics or any other attributes not specifically addressed, nor are they to be construed as an endorsement of the subject of the report or a recommendation for its use. There is no warranty by ICC Evaluation Service, LLC, express or implied, as to any finding or other matter in this report, or as to any product covered by the report.

Copyright © 2023 ICC Evaluation Service, LLC. All rights reserved.

<p>DIVISION: 03 00 00— CONCRETE</p> <p>Section: 03 16 00— Concrete Anchors</p> <p>DIVISION: 05 00 00— METALS</p> <p>Section: 05 05 19— Post-installed Concrete Anchors</p>	<p>REPORT HOLDER: DEWALT</p>	<p>EVALUATION SUBJECT: MINI-UNDERCUT+™ ANCHORS IN CRACKED AND UNCRACKED CONCRETE (DEWALT)</p>	
--	---	--	---

1.0 EVALUATION SCOPE

Compliance with the following codes:

- 2021, 2018, 2015 and 2012 [International Building Code® \(IBC\)](#)
- 2021, 2018, 2015 and 2012 [International Residential Code \(IRC\)](#)

For evaluation for compliance with codes adopted by [Los Angeles Department of Building and Safety \(LADBS\)](#), see [ESR-3912 LABC and LARC Supplement](#).

Property evaluated:

Structural

2.0 USES

The DEWALT Mini-Undercut+ anchor is used to anchor building components to the underside (i.e. formed surface) of cracked and uncracked normal-weight concrete and lightweight concrete having a specified compressive strength, f'_c , of 2,500 psi to 8,500 psi (17.2 MPa to 58.6 MPa) to resist static, wind and seismic, tension and shear loads. Use of anchors is limited to supporting non-structural components.

The anchors may also be installed in the underside of cracked and uncracked hollow-core concrete slabs having a minimum specified compressive strength, f'_c , of 6,000 psi (41.4 MPa). Use of anchors is limited to supporting non-structural components.

The anchor is an alternative to cast-in-place anchors described in Section 1901.3 of the 2021, 2018 and 2015 IBC, Sections 1908 and 1909 of the 2012 IBC. The anchors may be used in structures regulated by the IRC, provided an engineered design is submitted in accordance with IRC Section R301.1.3.

3.0 DESCRIPTION

3.1 Mini-Undercut+ Anchors:

Mini-Undercut+ anchors are internally threaded undercutting anchors which receive threaded steel inserts such as threaded rods and bolts in $\frac{3}{8}$ -inch (9.5 mm) diameter.

Available nominal size is $\frac{3}{8}$ -inch (9.5 mm). The anchors are manufactured from carbon steel and comprised of an undercutting sleeve and an internally threaded plow which have a minimum 0.0002-inch (5 μ m) zinc plating in accordance with ASTM B633. The Mini-Undercut+ anchor is illustrated in [Figure 1](#).

The anchors must be installed in predrilled holes using a stop drill bit and engaged with a setting tool using a recommended hammer drill (equipment supplied by DEWALT) as noted in [Table B](#) of this report. The anchor expands into the sides of the predrilled hole and interlocks with the base material during installation.

3.2 Steel Insert Elements:

Threaded steel insert elements must be threaded into the Mini-Undercut+ anchors to form a connection. The material properties of the steel bolts and threaded rods must comply with minimum ASTM A36 or equivalent.

3.3 Concrete and Hollow-core Concrete Slabs:

Normal-weight and lightweight concrete must comply with Sections 1903 and 1905 of the IBC. The minimum concrete compressive strength at the time of anchor installation is noted in Section 5.3 of this report. Hollow-core precast concrete slabs must comply with the configuration and dimensions as indicated in [Figure 4](#).

4.0 DESIGN AND INSTALLATION

4.1 Strength Design:

4.1.1 General: Design strength of anchors complying with the 2021 IBC, as well as Section R301.1.3 of the 2021 IRC must be determined in accordance with ACI 318-19 Chapter 17 and this report.

Design strength of anchors complying with the 2018 and 2015 IBC, as well as Section R301.1.3 of the 2018 and 2015 IRC must be determined in accordance with ACI 318-14 Chapter 17 and this report.

Design strength of anchors complying with the 2012 IBC, as well as Section R301.1.3 of the 2012 IRC, must be determined in accordance with ACI 318-11 Appendix D and this report.

Design parameters provided in [Tables 2](#) and [3](#) of this report are based on the 2021 (ACI 318-19), 2018 and 2015 IBC (ACI 318-14) and the 2012 IBC (ACI 318-11) unless noted otherwise in Section 4.1.1 through 4.1.11 of this report.

The strength design of anchors must comply with ACI 318-19 17.5.1.2, ACI 318-14 17.3.1 or ACI 318-11 D.4.1, as applicable, except as required in ACI 318-19 17.10, ACI 318-14 17.2.3 or ACI 318-11 D.3.3, as applicable. Strength reduction factors, ϕ , as given in [Tables 2](#) and [3](#) of this report, must be used in lieu of ACI 318-19 17.5.3, ACI 318-14 17.3.3 or ACI 318-11 D.4.3, as applicable, for load combinations calculated in accordance with Section 1605.1 of the 2021 IBC or Section 1605.2 of the 2018, 2015 and 2012 IBC, Section 5.3 of ACI 318 (-19 and -14), or Section 9.2 of ACI 318-11, as applicable. Strength reduction factors, ϕ , as given in Appendix C of ACI 318-11 shall not be used. The value of f'_c used in the calculation must be limited to a maximum of 8,000 psi (55.2 MPa), in accordance with ACI 318-19 17.3.1, ACI 318-14 17.2.7 or ACI 318-11 D.3.7, as applicable.

4.1.2 Requirements for Static Steel Strength in Tension, N_{sa} : The nominal static steel strength in tension, N_{sa} , of a single anchor must be calculated in accordance with ACI 318-19 17.6.1, ACI 318-14 17.4.1 or ACI 318-11 Section D.5.1, as applicable, for the threaded steel element, $N_{sa,rod}$, as illustrated in [Table 5](#) of this report. The lesser of $\phi N_{sa,rod}$ in [Table 5](#) or ϕN_{sa} provided in [Table 2](#) for the Mini-Undercut+ anchor shall be used as the steel strength in tension.

4.1.3 Requirements for Static Concrete Breakout Strength in Tension N_{cb} or N_{cbg} : The nominal concrete breakout strength of a single anchor or a group of anchors in tension, N_{cb} or N_{cbg} , respectively, must be calculated in accordance with ACI 318-19 17.6.2, ACI 318-14 17.4.2 or ACI 318-11 D.5.2, as applicable, with modifications as described in this section. The basic concrete breakout strength of a single anchor in tension in cracked concrete, N_b , must be calculated according to ACI 318-19 17.6.2.2, ACI 318-14 17.4.2.2 or ACI 318-11 D.5.2.2, as applicable, using the values of h_{ef} and k_{cr} as given in [Table 2](#) of this report. The nominal concrete breakout strength in tension in regions where analysis indicates no cracking in accordance with ACI 318-19 17.6.2.5.1(a), ACI 318-14 17.4.2.6 or ACI 318-11 D.5.2.6, as applicable, must be calculated with the value of k_{uncr} as given in [Table 2](#) of this report and with $\psi_{c,N} = 1.0$.

4.1.4 Requirements for Static Pullout Strength in Tension, N_{pn} : The nominal pullout strength of a single anchor or a group of anchors, in accordance with ACI 318-19 17.6.3, ACI 318-14 17.4.3 or ACI 318-11 D.5.3, as applicable, in cracked and uncracked concrete, $N_{p,cr}$ and $N_{p,uncr}$, respectively, is given in [Table 2](#). In lieu of ACI 318-19 17.6.3.3, ACI 318-14 17.4.3.6 or ACI 318-11 D.5.3.6, as applicable, $\psi_{c,P} = 1.0$ for all design cases. The nominal pullout strength in cracked concrete may be adjusted by calculation according to Eq-1:

$$N_{p,f'_c} = N_{p,cr} \sqrt{\frac{f'_c}{2,500}} \quad (\text{lb, psi}) \quad (\text{Eq-1})$$

$$N_{p,f'_c} = N_{p,cr} \sqrt{\frac{f'_c}{17.2}} \quad (\text{N, MPa})$$

where f'_c is the specified concrete compressive strength. For hollow-core concrete slabs, the value of 6,000 psi (41.4 MPa) must be substituted for the value of 2,500 psi (17.2 MPa) in the denominator.

Where value for $N_{p,uncr}$ is not provided in [Table 2](#) of this report, the pullout strength in tension need not be considered or evaluated.

4.1.5 Requirements for Static Steel Shear Capacity, V_{sa} : The nominal static steel strength in shear, V_{sa} , of a single anchor must be taken as the threaded steel element strength, $V_{sa,rod}$, given in [Table 5](#) of this report. The lesser of $\phi V_{sa,rod}$ in [Table 5](#) or ϕV_{sa} in [Table 3](#) for the Mini-Undercut+ anchor shall be used as the steel strength in shear, and must be used in lieu of the values derived by calculation from ACI 318-19 Eq. 17.7.1.2a or 17.7.1.2b, ACI 318-14 Eq. 17.5.1.2a or 17.5.1.2b; or ACI 318-11 Eq. D-28 or D-29, as applicable.

4.1.6 Requirements for Static Concrete Breakout Strength in Shear, V_{cb} or V_{cbg} : The nominal concrete breakout strength of a single anchor or group of anchors in shear, V_{cb} or V_{cbg} , respectively, must be calculated in accordance with ACI 318-19 17.7.2, ACI 318-14 17.5.2 or ACI 318-11 D.6.2, as applicable, with modifications as described in this section. The basic concrete breakout strength of a single anchor in shear, V_b , must be calculated in accordance with ACI 318-19 17.7.2.2.1, ACI 318-14 17.5.2.2 or ACI 318-11 D.6.2.2, as applicable, using the value of l_e and d_a given in [Table 3](#) of this report.

For anchors installed in hollow-core concrete slabs, the nominal concrete breakout strength of a single anchor or group of anchors in shear, V_{cb} or V_{cbg} , must be calculated in accordance with ACI 318-19 17.7.2, ACI 318-14 17.5.2 or ACI 318-11 D.6.2, as applicable, using the actual member cover thickness of the hollow-core, $h_{min,core}$, in lieu of h_{min} , in the determination of A_{vc} . Minimum member cover thickness for anchors in the hollow-core concrete slabs is given in [Table 1](#) and shown in [Figure 4](#) of this report, as applicable.

4.1.7 Requirements for Static Concrete Pryout Strength in Shear, V_{cp} or V_{cpg} : The nominal concrete pryout strength of a single anchor or group of anchors, V_{cp} or V_{cpg} , respectively, must be calculated in accordance with ACI 318-19 17.7.3, ACI 318-14 17.5.3 or ACI 318-11 D.6.3, as applicable, using the value of k_{cp} provided in [Table 3](#), and the value of N_{cb} or N_{cbg} as calculated in Section 4.1.3 of this report.

4.1.8 Requirements for Seismic Design:

4.1.8.1 General: For load combinations including seismic loads, the design must be performed in accordance with ACI 318-19 17.10, ACI 318-14 17.2.3 or ACI 318-11 D.3.3, as applicable. Modifications to ACI 318-19 17.10 or ACI 318-14 17.2.3 shall be applied under 2021, 2018 and 2015 IBC Section 1905.1.8, as applicable. For the 2012 IBC, Section 1905.1.9 shall be omitted.

The nominal steel strength and nominal concrete breakout strength for anchors in tension, and the nominal concrete breakout strength and pryout strength for anchors in shear, must be calculated according to ACI 318-19 17.6 and 17.7, ACI 318-14 17.4 and 17.5 or ACI 318-11 D.5 and D.6, respectively, as applicable, taking into account the corresponding values in [Tables 2](#) and [3](#) of this report.

The anchors comply with ACI 318 (-19 and -14) 2.3 or ACI 318-11 D.1, as applicable, as brittle steel elements and must be designed in accordance with ACI 318-19 17.10.4, 17.10.5 or 17.10.6 and 17.10.7, ACI 318-14 17.2.3.4, 17.2.3.5, 17.2.3.6, and 17.2.3.7; ACI 318-11 D.3.3.4, D.3.3.5, D.3.3.6 and D.3.3.7; or ACI 318-08 D.3.3.4, D.3.3.5 and D.3.3.6, as applicable.

The $\frac{3}{8}$ -inch-diameter (9.5 mm) Mini-Undercut+ anchors may be installed in regions designated as IBC Seismic Design Categories A through F.

4.1.8.2 Seismic Tension: The nominal steel strength and nominal concrete breakout strength for anchors in tension must be calculated according to ACI 318-19 17.6.1 and 17.6.2, ACI 318-14 17.4.1 and 17.4.2, or ACI 318-11 D.5.1 and D.5.2, as applicable, as described in Sections 4.1.2 and 4.1.3 of this report. In accordance with ACI 318-19 17.6.3.2.1, ACI 318-14 17.4.3.2 or ACI 318-11 D.5.3.2, as applicable, the appropriate value for nominal pullout strength in tension for seismic loads, $N_{p,eq}$, described in [Table 2](#) of this report, must be used in lieu of N_p . $N_{p,eq}$, and may be adjusted by calculations for concrete compressive strength in accordance with Eq-1 of this report.

4.1.8.3 Seismic Shear: The nominal concrete breakout strength and pryout strength for anchors in shear must be calculated according to ACI 318-19 17.7.2 and 17.7.3, ACI 318-14 17.5.2 or 17.5.3, or ACI 318-11 D.6.2 and D.6.3, respectively, as described in Sections 4.1.6 and 4.1.7 of this report. In accordance with ACI 318-19 17.7.1.2, ACI 318-14 17.5.1.2 or ACI 318-11 D.6.1.2, as applicable, the appropriate value for nominal steel strength in shear for seismic loads, $V_{sa,eq}$, described in [Table 3](#) of this report, must be used in lieu of V_{sa} .

4.1.9 Requirements for the Interaction of Tensile and Shear Forces: The effects of combined tensile and shear forces must be determined in accordance with ACI 318-19 17.8, ACI 318-14 17.6 or ACI 318-11 D.7.

4.1.10 Requirements for Critical Edge Distance, c_{ac} : In applications where $c < c_{ac}$ and supplemental reinforcement to control splitting of the concrete is not present, the concrete breakout strength in tension for uncracked concrete, calculated according to ACI 318-19 17.6.2, ACI 318-14 17.4.2 or ACI 318 D.5.2, as applicable, must be further multiplied by the factor $\psi_{cp,N}$ as given by Eq 2:

$$\psi_{cp,N} = \frac{c}{c_{ac}} \quad (\text{Eq-2})$$

whereby the factor $\psi_{cp,N}$ need not be taken less than $\frac{1.5h_{ef}}{c_{ac}}$. For all other cases, $\psi_{cp,N} = 1.0$. In lieu of using ACI 318-19 17.9.5, ACI 318-14 17.7.6 or ACI 318-11 D.8.6, as applicable, values of c_{ac} provided in [Table 2](#) of this report must be used, as applicable

4.1.11 Requirements for Minimum Member Thickness, Minimum Anchor Spacing and Minimum Edge Distance: In lieu of ACI 318-19 17.9.2, ACI 318-14 17.7.1 and 17.7.3, or ACI 318-11 D.8.1 and D.8.3, respectively, as applicable, the values of s_{min} and c_{min} as given in [Table 1](#) of this report must be used. In lieu of ACI 318-19 17.9.4, ACI 318-14 17.7.5 or ACI 318-11 D.8.5, as applicable, minimum member thicknesses, h_{min} , as given in [Table 1](#) of this report must be used.

4.1.12 Lightweight Concrete: For the use of anchors in lightweight concrete the modification factor λ_a equal to 0.8λ is applied to all values of $\sqrt{f'_c}$ affecting N_n and V_n .

For ACI 318-19 (2021 IBC), ACI 318-14 (2018 and 2015 IBC), and ACI 318-11 (2012 IBC), λ shall be determined in accordance with the corresponding version of ACI 318.

4.2 Allowable Stress Design (ASD):

4.2.1 General: Design values for use with allowable stress design load combinations calculated in accordance with Section 1605.1 of the 2021 IBC or Section 1605.3 of the 2018, 2015 and 2012 IBC must be established using the following equations:

$$T_{allowable,ASD} = \phi N_n / \alpha \quad (\text{Eq-3})$$

$$V_{allowable,ASD} = \phi V_n / \alpha \quad (\text{Eq-4})$$

where:

$$T_{allowable,ASD} = \text{Allowable tension load (lbf or kN)}$$

$$V_{allowable,ASD} = \text{Allowable shear load (lbf or kN)}$$

ϕN_n = Lowest design strength of an anchor or anchor group in tension as determined in accordance with ACI 318 (-19 and -14) Chapter 17 and 2021, 2018 and 2015 IBC Section 1905.1.8, ACI 318-11 Appendix D, and Section 4.1 of this report, as applicable. For the 2012 IBC, Section 1905.1.9 shall be omitted.

ϕV_n = Lowest design strength of an anchor or anchor group in shear as determined in accordance with ACI 318 (-19 and -14) Chapter 17 and 2021, 2018 and 2015 IBC Section 1905.1.8, ACI 318-11 Appendix D, and Section 4.1 of this report, as applicable. For the 2012 IBC, Section 1905.1.9 shall be omitted.

α = Conversion factor calculated as a weighted average of the load factors for the controlling load combination. In addition, α must include all applicable factors to account for nonductile failure modes and required over-strength.

Limits on edge distance, anchor spacing and member thickness as given in [Table 1](#) of this report must apply.

4.2.2 Interaction of Tensile and Shear Forces: The interaction must be calculated and consistent with ACI 318-19 17.8, ACI 318-14 17.6 or ACI 318-11 D.7, as applicable, as follows:

For shear loads $V \leq 0.2V_{allowable,ASD}$, the full allowable load in tension $T_{allowable,ASD}$ must be permitted.

For tension loads $T \leq 0.2T_{allowable,ASD}$, the full allowable load in shear $V_{allowable,ASD}$ must be permitted.

$$\text{For all other cases: } \frac{T_{applied}}{T_{allowable,ASD}} + \frac{V_{applied}}{V_{allowable,ASD}} \leq 1.2 \quad (\text{Eq-5})$$

4.3 Installation:

Installation parameters are provided in [Table 1](#) and [Figures 1A, 2, 3 and 4](#) of this report. Anchor locations must comply with this report and plans and specifications approved by the code official. The Mini-Undercut+ anchor must be installed according to manufacturer's printed installation instructions and this report. Anchors must be installed in holes drilled into concrete using carbide-tipped masonry drill bits complying with ANSI B212.15-1994. The stop drill bit size and drilled hole depth must be in accordance with [Table 1](#). The anchors must be installed in drilled holes with a powered hammer drill and fitted with a Mini-Undercut+ setting tool supplied by DEWALT. The allowable ranges of installation parameters for the Mini-Undercut+ anchors are given in [Table 1](#). The anchors must be driven until the shoulder of the Mini-Undercut+ anchor is flush with the surface of the concrete. The minimum thread engagement of a threaded rod or bolt insert element assembly into the Mini-Undercut+ anchor must be full anchor depth.

4.4 Special Inspection:

Periodic special inspection is required, in accordance with Section 1705.1.1 and Table 1705.3 of the 2021, 2018, 2015 IBC or 2012 IBC, as applicable. The special inspector must make periodic inspections during anchor installation to verify anchor type, anchor dimensions, concrete type, concrete compressive strength, hole dimensions, drill bit size and type, anchor spacing, edge distances, concrete thickness, anchor embedment, and adherence to the installation instructions. The special inspector must be present as often as required in accordance with the “statement of special inspection.”

5.0 CONDITIONS OF USE:

The Mini-Undercut+ anchors described in this report comply with, or are suitable alternatives to what is specified in, those codes listed in Section 1.0 of this report, subject to the following conditions:

- 5.1 The anchors must be installed in accordance with the manufacturer's printed installation instructions and this report. In case of conflict, this report governs.
- 5.2 Anchor sizes, dimensions and minimum embedment depths are as set forth in this report.
- 5.3 The anchors must be limited to installation in the formed surface of cracked and uncracked normal-weight and lightweight concrete having a specified compressive strength, f'_c , of 2,500 psi to 8,500 psi (17.2 MPa to 58.6 MPa), and cracked and uncracked hollow-core concrete slabs with the configuration and dimensions as indicated in [Figure 4](#) having a minimum specified compressive strength, f'_c , of 6,000 psi (41.4 MPa).
- 5.4 The values of f'_c used for calculation purposes must not exceed 8,000 psi (55.1 MPa).
- 5.5 The concrete shall have attained its minimum design strength prior to installation of the anchors.
- 5.6 Strength design values must be established in accordance with Section 4.1 of this report.
- 5.7 Allowable stress design values must be established in accordance with Section 4.2 of this report.
- 5.8 Anchor spacing and edge distance, as well as minimum member thickness, must comply with [Table 1](#) and [Figures 2](#) and [4](#) of this report.
- 5.9 Prior to installation, calculations and details demonstrating compliance with this report must be submitted to the code official. The calculations and details must be prepared by a registered design professional where required by the statutes of the jurisdiction in which the project is to be constructed.
- 5.10 Since an ICC-ES acceptance criteria for evaluating data to determine the performance of anchors subjected to fatigue or shock loading is unavailable at this time, the use of these anchors under such conditions is beyond the scope of this report.
- 5.11 Anchors may be installed in regions of concrete where cracking has occurred or where analysis indicates cracking may occur ($f_t > f_r$), subject to the conditions of this report.
- 5.12 Anchors may be used to resist short-term loading due to wind or seismic forces (Seismic Design Categories A through F under the IBC), subject to the conditions of this report.
- 5.13 Anchors are not permitted to support fire-resistance-rated construction. Where not otherwise prohibited by the code, anchors are permitted for installation in fire-resistance-rated construction provided that at least one of the following conditions is fulfilled:
 - The anchors are used to resist wind or seismic forces only.
 - Anchors are used to support nonstructural elements.
- 5.14 Special inspection must be provided in accordance with Section 4.4 of this report.
- 5.15 Use of anchors is limited to supporting non-structural components.
- 5.16 Use of anchors is limited to dry, interior locations.
- 5.17 Anchors are manufactured under an approved quality-control program with inspections by ICC-ES.

6.0 EVIDENCE SUBMITTED

- 6.1 Data in accordance with the [ICC-ES Acceptance Criteria for Mechanical Anchors in Concrete Elements \(AC193\)](#), dated October 2017 (Editorially revised December 2020), which incorporates requirements in ACI 355.2-19 / 355.2-07, for use in cracked and uncracked concrete; including but not limited to reference, reliability and service-condition tests in cracked and uncracked concrete.
- 6.2 Reports of tension and shear tests of anchors in hollow-core concrete slabs in accordance with applicable sections as referenced in Section 6.1 of this report.
- 6.3 Quality-control documentation in accordance with the [ICC-ES Acceptance Criteria for Quality Documentation \(AC10\)](#) dated January 2019.

7.0 IDENTIFICATION

- 7.1 The Mini-Undercut+ anchors have only one size and one type, which is identified in the field by their unique dimensional characteristics and packaging. Packages are identified with the company name (DEWALT), anchor name, part number, size, and the evaluation report number (ESR-3912).
- 7.2 The report holder's contact information is the following:

DEWALT
701 EAST JOPPA ROAD
TOWSON, MARYLAND 21286
(800) 524-3244
www.DEWALT.com
anchors@DEWALT.com

TABLE A—INSTALLATION AND DESIGN INDEX¹

Product Name	Installation Specifications	Tension Design Data		Shear Design Data	
		Concrete	Hollow-core Concrete Slabs	Concrete	Hollow-core Concrete Slabs
Mini-Undercut+	Table 1	Table 2	Table 2	Table 3	Table 3
Concrete Type	Concrete State	Anchor Nominal Size		Seismic Design Categories ²	
Normal-weight	Cracked	3/8-inch		A through F	
	Uncracked	3/8-inch		A and B	

For **SI**: 1 inch = 25.4 mm. For **pound-inch** units: 1 mm = 0.03937 inch.

¹Reference ACI 318-19 17.5.2, ACI 318-14 17.3.1.1 or ACI 318-11 D.4.1.1, as applicable. The controlling strength is decisive from all appropriate failure modes (i.e. steel, concrete breakout, pullout, pryout, as applicable) and design assumptions.

²See Section 4.1.8 for requirements for seismic design, where applicable.

TABLE B—MINI-UNDERCUT+ SYSTEM

SDS Stop Drill Bits	Mini-Undercut+ Anchor	SDS Setting Tool	DEWALT Recommended SDS Hammer-Tools
PPA2431720	PFM2111820	PFM2101720	DCH273, DCH133, D25133, D25262, DCH263, D25263 ¹

¹Refer to Table 1 for requirements of approximate tool impact power.

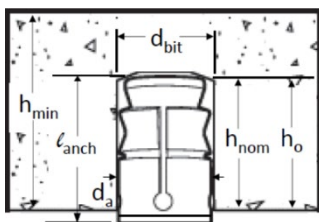

FIGURE 1A—MINI- UNDERCUT+ ANCHOR DETAIL Before (Left Picture) and After (Right Picture) Anchor Setting

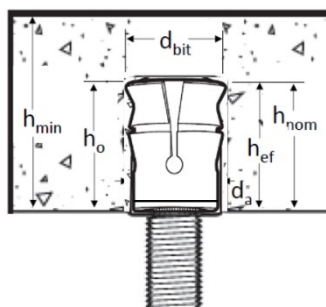

FIGURE 1B—SDS STOP DRILL BIT (Top Picture), MINI-UNDERCUT+ ANCHOR (Center Picture) AND SETTING TOOL (Bottom Picture)

The DEWALT drilling systems shown below collect and remove dust with a HEPA dust extractor during the hole drilling operation in dry base materials using hammer-drills.

DEWALT Dust Removal Drilling System with HEPA Dust Extractor Options		
Tool	Accessories and Shrouds	Dust Extractor
SDS-Max Drills		
 Cordless  Corded	 SDS-Max Hollow Drill Bits	 Dust Extractor
	 SDS-Max Drill Bits With Shroud	
SDS-Plus Drills		
 Cordless  Corded	 SDS-Plus Drill Bits  SDS-Plus Stop Drill Bits	 Cordless On-board Dust Extractor
	 SDS-Plus Hollow Drill Bits	 Dust Extractor
	 SDS-Plus Drill Bits With Telescope  SDS-Plus Drill Bits With Suction Tube	
	 SDS-Plus Drill Bits With Shroud  SDS-Plus Stop Drill Bits With Shroud	

FIGURE 1C—EXAMPLES DEWALT DUST REMOVAL DRILLING SYSTEMS WITH HEPA DUST EXTRACTORS FOR ILLUSTRATION

TABLE 1—MINI-UNDERCUT+ ANCHOR INSTALLATION SPECIFICATIONS AND SUPPLEMENTAL INFORMATION^{1,2,3}

Anchor Property / Setting Information	Symbol	Units	Nominal Anchor Size / Threaded Rod Diameter (inch)	
			³ / ₈	
Nominal outside anchor diameter	d_a	in.	0.625	
Internal thread diameter (UNC)	d	in.	³ / ₈	
Nominal stop drill bit diameter (ANSI)	d_{bit}	in.	⁵ / ₈	
Minimum nominal embedment depth	h_{nom}	in.	³ / ₄	
Effective embedment	h_{ef}	in.	0.75	
Hole depth in base material	h_o	in.	³ / ₄	
Overall anchor length (prior to setting)	l_{anch}	in.	¹⁵ / ₁₆	
Approximate tool impact power (hammer-drill)	-	J	2.1 to 3	
Minimum concrete member thickness	h_{min}	in.	2 ¹ / ₂	
Minimum cover thickness in hollow core concrete slabs (see Figure 4)	$h_{min,core}$	in.	1 ¹ / ₂	
Minimum edge distance	c_{min}	in.	2 ¹ / ₂	
Minimum spacing distance	s_{min}	in.	3	
Minimum diameter of hole clearance in fixture for steel insert element (following anchor installation)	d_h	in.	⁷ / ₁₆	
Approximate depth of internal thread	-	in.	¹³ / ₃₂	
Max. tightening torque for threaded steel insert element (following anchor installation, as applicable; see Figure 2)	T_{max}	ft.-lb.	5	
Effective tensile stress area (anchor body)	A_{se}	in. ²	0.044	
Minimum specified ultimate strength	f_{uta}	psi	95,000	
Minimum specified yield strength	f_{ya}	psi	76,000	
Mean axial stiffness ⁴	Uncracked concrete	β_{uncr}	lbf/in.	50,400
	Cracked concrete	β_{cr}	lbf/in.	29,120

For SI: 1 inch = 25.4 mm, 1 ft-lb = 1.356 N-m.

¹The information presented in this table is to be used in conjunction with the design criteria of ACI 318 (-19 or -14) Chapter 17 or ACI 318-11 Appendix D, as applicable.

²For installation detail for anchors in hollow-core concrete slabs, see Figure 4.

³The embedment depth, h_{nom} , is measured from the outside surface of the concrete member to the embedded end of the anchor, see Figure 1A.

⁴Mean values shown, actual stiffness varies considerably depending on concrete strength, loading and geometry of application.

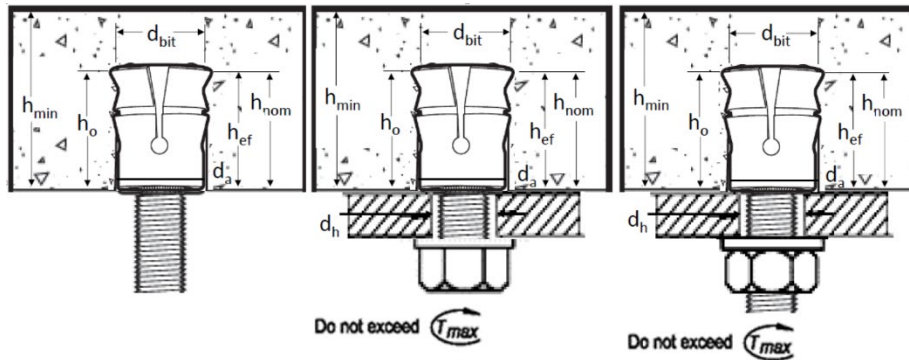

FIGURE 2—MINI-UNDERCUT+ ANCHOR INSTALLED WITH STEEL INSERT ELEMENT

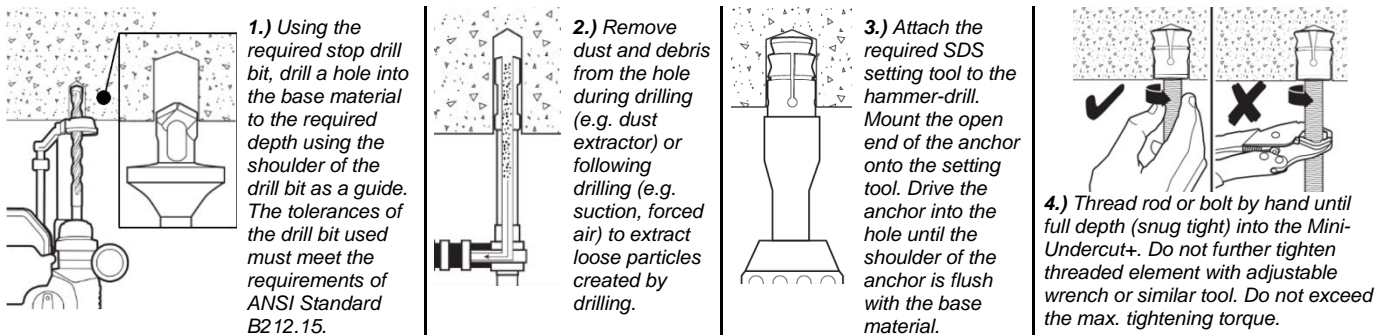

FIGURE 3—MINI-UNDERCUT+ ANCHOR INSTALLATION INSTRUCTIONS IN THE UNDERSIDE FORMED SURFACE OF CONCRETE

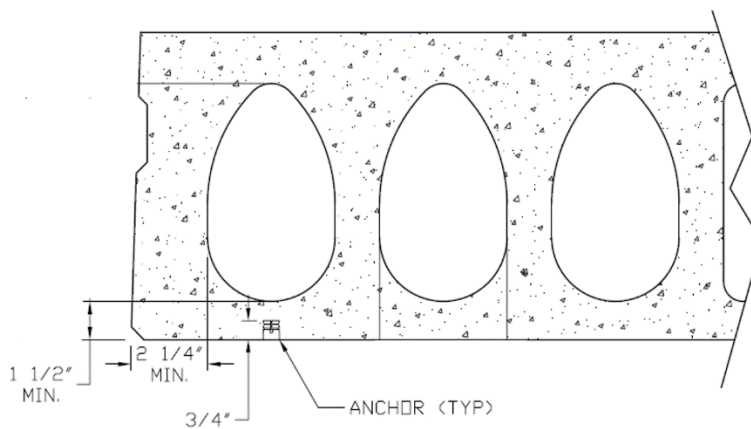

FIGURE 4—MINI-UNDERCUT+ INSTALLATION DETAIL FOR ANCHORS IN THE UNDERSIDE OF HOLLOW-CORE CONCRETE SLABS

TABLE 2—TENSION DESIGN INFORMATION FOR MINI-UNDERCUT+ ANCHORS IN THE UNDERSIDE OF CONCRETE AND THE UNDERSIDE OF HOLLOW CORE CONCRETE SLABS^{1,2,3,4,5,6,7}

Design Characteristic	Notation	Units	Nominal Anchor Size / Threaded Rod Diameter (in.)
			³ / ₈ inch
Anchor category	1, 2 or 3	-	1
Nominal embedment depth	h_{nom}	in.	³ / ₄
Effective embedment	h_{ef}	in.	0.75
STEEL STRENGTH IN TENSION (ACI 318-19 17.6.1, ACI 318-14 17.4.1 or ACI 318-11 D.5.1)			
Steel strength in tension	N_{sa}	lb	4,180
Reduction factor, steel strength	ϕ	-	0.65
CONCRETE BREAKOUT STRENGTH IN TENSION (ACI 318-19 17.6.2, ACI 318-14 17.4.2 or ACI 318-11 D.5.2)			
Effectiveness factor for uncracked concrete	k_{uncr}	-	24
Effectiveness factor for cracked concrete	k_{cr}	-	17
Modification factor for cracked and uncracked concrete	$\psi_{c,N}$	-	1.0 (see note 5)
Critical edge distance (uncracked concrete only)	c_{ac}	in.	2.5
Reduction factor, concrete breakout strength	ϕ	-	0.40
PULLOUT STRENGTH IN TENSION (ACI 318-19 17.6.3, ACI 318-14 17.4.3 or ACI 318-11 D.5.3)			
Pullout strength, uncracked concrete	$N_{p,uncr}$	lb	See note 7
Pullout strength, cracked concrete	$N_{p,cr}$	lb	455
Reduction factor, pullout strength	ϕ	-	0.40
PULLOUT STRENGTH IN TENSION FOR SEISMIC APPLICATIONS (ACI 318-19 17.10.3, ACI 318-14 17.2.3.3 or ACI 318-11 D.3.3.3)⁸			
Characteristic pullout strength, seismic	$N_{p,eq}$	lb	410
Reduction factor, pullout strength, seismic	ϕ	-	0.40

For SI: 1 inch = 25.4 mm, 1 ksi = 6.894 N/mm²; 1 lbf = 0.0044 kN.

¹The data in this table is intended to be used with the design provisions of ACI 318 (-19 or -14) Chapter 17 or ACI 318-11 Appendix D, as applicable; for anchors resisting seismic load combinations the additional requirements of ACI 318-19 17.10, ACI 318-14 17.2.3 or ACI 318-11 D.3.3, as applicable, shall apply.

²Installation must comply with manufacturer's printed installation instructions and details.

³All values of ϕ are applicable with the load combinations of 2021 IBC Section 1605.1 or 2018, 2015 and 2012 IBC Section 1605.2, ACI 318 (-19 or -14) Section 5.3, or ACI 318-11 Section 9.2. For concrete failure modes, no increase for ACI 318-19 17.5.3, ACI 318-14 17.3.3 Condition A or ACI 318-11 D.4.3 Condition A is permitted.

⁴The steel strength shown in this table is for the Mini-Undercut+ anchors only. Design professional is responsible for checking threaded rod strength in tension, shear, and combined tension and shear, as applicable. See Table 5 for steel design information for threaded rod elements.

⁵Select the appropriate effectiveness factor for cracked concrete (k_{cr}) or uncracked concrete (k_{uncr}) and use $\psi_{c,N} = 1.0$.

⁶For calculation of N_m see Section 4.1.4 of this report. For all design cases, $\psi_{c,P} = 1.0$. The characteristic pullout strength for concrete compressive strengths greater than 2,500 psi for anchors may be increased by multiplying the value in the table by $(f'_c / 2,500)^{0.5}$ for psi or $(f'_c / 17.2)^{0.5}$. For hollow-core concrete slabs the characteristic pullout strength for concrete compressive strengths greater than 6,000 psi for anchors may be increased by multiplying the value in the table by $(f'_c / 6,000)^{0.5}$ for psi or $(f'_c / 41.4)^{0.5}$.

⁷Pullout strength does not control the design of indicated anchors. Do not calculate pullout strength for the indicated anchor size and embedment.

⁸Reported values for characteristic pullout strength in tension for seismic applications are based on test results per ACI 355.2, Section 9.5 and must be used for design.

TABLE 3—SHEAR DESIGN INFORMATION FOR MINI-UNDERCUT+ ANCHORS IN THE UNDERSIDE OF CONCRETE AND THE UNDERSIDE OF HOLLOW CORE CONCRETE SLABS^{1,2,3,4}

Design Characteristic	Notation	Units	Nominal Anchor Size / Threaded Rod Diameter (in.)
			³ / ₈ inch
Anchor category	1, 2 or 3	-	1
Nominal embedment depth	h_{nom}	in.	³ / ₄
Effective embedment	h_{ef}	in.	0.75
STEEL STRENGTH IN SHEAR (ACI 318-19 17.7.1, ACI 318-14 17.5.1 or ACI 318-11 D.6.1)⁵			
Steel strength in shear	V_{sa}	lb	985
Reduction factor, steel strength	ϕ	-	0.60
STEEL STRENGTH IN SHEAR FOR SEISMIC APPLICATIONS (ACI 318-19 17.10.3, ACI 318-14 17.2.3.3 or ACI 318-11 D.3.3.3)⁶			
Steel strength in shear, seismic	$V_{sa,eq}$	lb	895
Reduction factor, steel strength in shear, seismic	ϕ	-	0.60
CONCRETE BREAKOUT STRENGTH IN SHEAR (ACI 318-19 17.7.2, ACI 318-14 17.5.2 or ACI 318-11 D.6.2)			
Load bearing length of anchor in shear	l_e	in.	0.75
Nominal outside anchor diameter	d_a	in.	0.625
Reduction factor, concrete breakout strength	ϕ	-	0.45
PRYOUT STRENGTH IN SHEAR (ACI 318-19 17.7.3, ACI 318-14 17.5.3 or ACI 318-11 D.6.3)			
Coefficient for prout strength	k_{cp}	-	1.0
Reduction factor, prout strength	ϕ	-	0.45

For **SI**: 1 inch = 25.4 mm, 1 lbf = 0.0044 kN.

¹The data in this table is intended to be used with the design provisions of ACI 318 (-19 or -14) Chapter 17 or ACI 318-11 Appendix D, as applicable; for anchors resisting seismic load combinations the additional requirements of ACI 318-19 17.10, ACI 318-14 17.2.3 or ACI 318-11 D.3.3, as applicable shall apply

²Installation must comply with manufacturer's printed installation instructions and details.

³All values of ϕ are applicable with the load combinations of IBC Section 1605.2, ACI 318 (-19 or -14) Section 5.3, or ACI 318-11 Section 9.2. For concrete failure modes, no increase for ACI 318-19 17.5.3 supplementary reinforcement present, ACI 318-14 17.3.3 Condition A or ACI 318-11 D.4.3 Condition A is permitted.

⁴The strength shown in this table is for the Mini-Undercut+ anchors only. Design professional is responsible for checking threaded rod strength in tension, shear, and combined tension and shear, as applicable. See Table 5 for steel design information for threaded rod elements.

⁵Reported values for steel strength in shear are based on test results per ACI 355.2, Section 9.4 (in cracked concrete) and must be used for design in lieu of the calculated results using equation 17.7.1.2b in ACI 318-19, 17.5.1.2b in ACI 318-14 or D-29 in ACI 318-11 D.6.1.2.

⁶Reported values for steel strength in shear for the Mini-Undercut+ anchors are for seismic applications and based on test results in accordance with ACI 355.2, Section 9.6 and must be used for design.

TABLE 4—SPECIFICATIONS AND PHYSICAL PROPERTIES OF COMMON CARBON STEEL THREADED ROD ELEMENTS

THREADED ROD SPECIFICATION		UNITS	MIN. SPECIFIED ULTIMATE STRENGTH, f_{uta}	MIN. SPECIFIED YIELD STRENGTH 0.2 PERCENT OFFSET, f_{ya}	f_{uta} / f_{ya}	ELONGATION MINIMUM PERCENT	REDUCTION OF AREA MIN. PERCENT	RELATED NUT SPECIFICATION ³
Carbon Steel	ASTM A36/A36M ¹ and F1554 ² Grade 36	psi	58,000	36,000	1.61	23	40 (50 for A36)	ASTM A194 / A563 Grade A

For **SI**: 1 inch = 25.4 mm, 1 psi = 0.006897 MPa. For **pound-inch** units: 1 mm = 0.03937 inch, 1 MPa = 145.0 psi.

¹Standard Specification for Carbon Structural Steel.

²Standard Specification for Anchor Bolts, Steel, 36, 55, and 105-ksi Yield Strength.

³Where nuts are applicable, nuts of other grades and style having specified proof load stress greater than the specified grade and style are also suitable.

TABLE 5—STEEL DESIGN INFORMATION FOR THREADED ROD ELEMENTS USED WITH MINI-UNDERCUT+ ANCHORS^{1,2,3,4}

DESIGN INFORMATION	SYMBOL	UNITS	³ / ₈ -inch
Threaded rod nominal outside diameter	d_{rod}	in.	0.375
Threaded rod effective cross-sectional area	A_{se}	in ²	0.078
Nominal tension strength of threaded rod as governed by steel strength	$N_{sa,rod}$	ASTM A36 or F1554, Grade 36	lb
Nominal tension strength of threaded rod as governed by steel strength, seismic			
Nominal shear strength of threaded rod as governed by steel strength	$V_{sa,rod}$	ASTM A36 or F1554, Grade 36	lb
Nominal shear strength of threaded rod as governed by steel strength, seismic			

For **SI**: 1 inch = 25.4 mm, 1 pound = 0.00445 kN, 1 in² = 645.2 mm². For **pound-inch** unit: 1 mm = 0.03937 inches.

¹Values provided for steel element material types, or equivalent, based on minimum specified strengths; $N_{sa,rod}$ and $V_{sa,rod}$ calculated in accordance with equations 17.7.1.2a and 17.7.1.2b in ACI 318-19, 17.5.1.2a and 17.5.1.2b in ACI 318-14 or D-28 and D-29 in ACI 318-11, respectively, as applicable. $V_{sa,rod,eq}$ must be taken as 0.7 $V_{sa,rod}$.

² ϕN_{sa} shall be the lower of the $\phi N_{sa,rod}$ or ϕN_{sa} for static steel strength in tension; for seismic loading $\phi N_{sa,eq}$ shall be the lower of the $\phi N_{sa,rod,eq}$ or $\phi N_{sa,eq}$.

³ ϕV_{sa} shall be the lower of the $\phi V_{sa,rod}$ or ϕV_{sa} for static steel strength in tension; for seismic loading $\phi V_{sa,eq}$ shall be the lower of the $\phi V_{sa,rod,eq}$ or $\phi V_{sa,eq}$.

⁴Strength reduction factors shall be taken from ACI 318-19 17.5.3, ACI 318-14 17.3.3 or ACI 318-11 D.4.3, as applicable, for steel elements. Strength reduction factors for load combinations in accordance with ACI 318-19 and ACI 318-14 5.3 or ACI 318-11 9.2, as applicable, governed by steel strength of ductile steel elements shall be taken as 0.75 for tension and 0.65 for shear. The value of ϕ applies when the load combinations of 2021 IBC Section 1605.1 or 2018, 2015 and 2012 Section 1605.2 of the IBC, ACI 318 (-19 or -14) 5.3 or ACI 318-11 9.2, as applicable, are used in accordance with ACI 318-19 17.5.3, ACI 318-14 17.3.3 or ACI 318-11 D.4.3, as applicable.

DIVISION: 03 00 00—CONCRETE

Section: 03 16 00—Concrete Anchors

DIVISION: 05 00 00—METALS

Section: 05 05 19—Post-installed Concrete Anchors

REPORT HOLDER:

DEWALT

EVALUATION SUBJECT:**MINI-UNDERCUT+™ ANCHORS IN CRACKED AND UNCRACKED CONCRETE (DEWALT)****1.0 REPORT PURPOSE AND SCOPE****Purpose:**

The purpose of this evaluation report supplement is to indicate that DEWALT Mini-Undercut+™ anchors in cracked and uncracked concrete, described in ICC-ES evaluation report [ESR-3912](#), have also been evaluated for compliance with the codes noted below as adopted by Los Angeles Department of Building and Safety (LADBS).

Applicable code editions:

- 2020 *City of Los Angeles Building Code* (LABC)
- 2020 *City of Los Angeles Residential Code* (LARC)

2.0 CONCLUSIONS

The DEWALT Mini-Undercut+™ anchors in cracked and uncracked concrete, described in Sections 2.0 through 7.0 of the evaluation report [ESR-3912](#), comply with LABC Chapter 19, and LARC, and are subject to the conditions of use described in this supplement.

3.0 CONDITIONS OF USE

The DEWALT Mini-Undercut+™ anchors described in this evaluation report supplement must comply with all of the following conditions:

- All applicable sections in the evaluation report [ESR-3912](#).
- The design, installation, conditions of use and labeling of the anchors are in accordance with the 2018 International Building Code® (IBC) provisions noted in the evaluation report [ESR-3912](#).
- The design, installation and inspection are in accordance with additional requirements of LABC Chapters 16 and 17, as applicable.
- Under the LARC, an engineered design in accordance with LARC Section R301.1.3 must be submitted.
- The allowable and strength design values listed in the evaluation report and tables are for the connection of the anchors to the concrete. The connection between the anchors and the connected members shall be checked for capacity (which may govern).

This supplement expires concurrently with the evaluation report, reissued October 2023.

DIVISION: 03 00 00—CONCRETE

Section: 03 16 00—Concrete Anchors

DIVISION: 05 00 00—METALS

Section: 05 05 19—Post-Installed Concrete Anchors

REPORT HOLDER:

DEWALT

EVALUATION SUBJECT:

MINI-UNDERCUT+™ ANCHORS IN CRACKED AND UNCRACKED CONCRETE (DEWALT)

1.0 REPORT PURPOSE AND SCOPE

Purpose:

The purpose of this evaluation report supplement is to indicate that the DEWALT Mini-Undercut+ anchor in cracked and uncracked concrete, described in ICC-ES evaluation report ESR-3912, have also been evaluated for compliance with the codes noted below.

Applicable code editions:

- 2020 *Florida Building Code—Building*
- 2020 *Florida Building Code—Residential*

2.0 CONCLUSIONS

The DEWALT Mini-Undercut+ anchor, described in Sections 2.0 through 7.0 of the evaluation report ESR-3912, comply with the *Florida Building Code—Building* and the *Florida Building Code—Residential*, provided the design requirements are determined in accordance with the *Florida Building Code—Building* or the *Florida Building Code—Residential*, as applicable. The installation requirements noted in ICC-ES evaluation report ESR-3912 for the 2018 *International Building Code*® meet the requirements of the *Florida Building Code—Building* or the *Florida Building Code—Residential*, as applicable.

Use of the DEWALT Mini-Undercut+ anchor has also been found to be in compliance with the High-Velocity Hurricane Zone Provisions of the *Florida Building Code—Building* and the *Florida Building Code—Residential* with the following condition:

- a) For connections subject to uplift, the connection must be designed for no less than 700 pounds (3114 N).

For products falling under Florida Rule 61G20-3, verification that the report holder's quality assurance program is audited by a quality-assurance entity approved by the Florida Building Commission for the type of inspections being conducted is the responsibility of an approved validation entity (or the code official when the report holder does not possess an approval by the Commission).

This supplement expires concurrently with the evaluation report, reissued October 2023.