

ICC-ES Evaluation Report

ESR-3864

Reissued May 2024

This report also contains:



Revised July 2024

- **CBC Supplement**

Subject to renewal May 2026

ICC-ES Evaluation Reports are not to be construed as representing aesthetics or any other attributes not specifically addressed, nor are they to be construed as an endorsement of the subject of the report or a recommendation for its use. There is no warranty by ICC Evaluation Service, LLC, express or implied, as to any finding or other matter in this report, or as to any product covered by the report.

Copyright © 2024 ICC Evaluation Service, LLC. All rights reserved.

<p>DIVISION: 03 00 00— CONCRETE</p> <p>Section: 03 15 19— Cast-in Concrete Anchors</p> <p>Section: 03 16 00— Concrete Anchors</p>	<p>REPORT HOLDER: ERICO INTERNATIONAL CORPORATION, A DIVISION OF NVENT</p>  <p>CADDY</p>	<p>EVALUATION SUBJECT: CADDY ROD LOCK PLYWOOD FORM (CRLW) AND CADDY ROD LOCK METAL DECKING (CRLM) HEADED CAST-IN SPECIALTY INSERTS IN CRACKED AND UNCRACKED CONCRETE</p>	
--	---	--	---

1.0 EVALUATION SCOPE

Compliance with the following codes:

- 2024, 2021, 2018, 2015, 2012, and 2009 [International Building Code® \(IBC\)](#)
- 2024, 2021, 2018, 2015, 2012, and 2009 [International Residential Code® \(IRC\)](#)

Property evaluated:

- Structural

2.0 USES

The CADDY ROD LOCK Plywood Form (CRLW) Headed Cast-In Specialty Insert is used to resist static, wind, and seismic (Seismic Design Categories A through F) tension and shear loads in cracked and uncracked normal-weight or lightweight concrete having a specified compressive strength, f'_c , of 2,500 psi to 10,000 psi (17.2 MPa to 68.9 MPa).

The CADDY ROD LOCK Metal Decking (CRLM) Headed Cast-In Specialty Insert is used to resist static, wind, and seismic (Seismic Design Categories A through F) tension and shear loads in the soffit of cracked and uncracked normal-weight concrete and sand-lightweight concrete on steel deck having a specified compressive strength, f'_c , of 3,000 psi to 10,000 psi (20.7 MPa to 68.9 MPa).

Reference to “inserts” in this report refers to the proprietary specialty anchorage products (CRLW and CRLM) used in concrete; reference to “steel insert elements” refers to threaded rods or bolts; reference to “anchors” or “insert anchor system” in this report refers to the installed inserts in concrete with threaded rods or bolts.

The insert anchor system is an alternative to cast-in anchors described in Section 1901.3 of the 2024, 2021, 2018 and 2015 IBC, Sections 1908 and 1909 of the 2012 IBC and Sections 1911 and 1912 of the 2009 IBC. The insert anchor system may be used where an engineered design is submitted in accordance with Section R301.1.3 of the IRC.

3.0 DESCRIPTION

3.1 CADDY ROD LOCK CRLW and CRLM:

CRLW and CRLM inserts are steel internally threaded headed cast-in specialty inserts which receive threaded steel insert elements such as threaded rods and bolts in $\frac{3}{8}$ -inch and $\frac{1}{2}$ -inch thread diameters.

The CRLW and CRLM insert bodies are manufactured from carbon steel and have a minimum 5.1 μm (0.0002 inch) zinc coating. The inserts are designed with a bearing head that is cast into the concrete, and an internally spring loaded plunger to which a threaded rod is fastened. The CRLW steel insert body is covered in a non-structural plastic housing sleeve and three nails that are secured in the housing sleeve. The CRLM steel insert body has an outer spring and washer, and outer plastic sleeve, which secure the insert to the metal deck before the concrete is placed. The CRLW is illustrated in [Figure 1](#) and CRLM is illustrated in [Figure 2](#).

The CRLW insert is installed into the wood-form for a concrete member using the attached nails prior to the casting of the concrete. The threaded rod or bolt can be fastened into the CRLW insert from below after the wood-form is removed from the concrete.

The CRLM insert is installed into a pre drilled hole cut into the topside of the metal deck. The plastic component has flexible flared flutes that may be pushed through the hole drilled in the metal deck, and then serves to clamp the insert with the plastic flutes on one side of the metal deck and the spring washer on the other side. The metal deck is then filled with concrete. The threaded rod or bolt can then be fastened into the CRLM insert from below.

3.2 Steel Insert Elements:

3.2.1 Threaded Steel Rods and Bolts: Threaded steel rods (all-thread) or bolts must be threaded on their inserted end into the CRLW or CRLM. [Table 3](#) includes design information for threaded rod or bolts for the applicable diameters. Carbon steel threaded rods or bolts must be furnished with a minimum 5.1 μm (0.0002 inch) zinc plating.

3.2.2 Ductility: In accordance with ACI 318 (-19 and -14) 2.3 or ACI 318-11 D.1, in order for a steel anchor element to be considered ductile, the tested elongation must be at least 14 percent and the reduction of area must be at least 30 percent. Steel elements with a tested elongation of less than 14 percent or a reduction of area less than 30 percent, or both, are considered brittle. Values for common steel threaded rod insert elements are provided in [Table 3](#) of this report. Where values are nonconforming or unstated, the steel element must be considered brittle.

3.3 Concrete:

Normal-weight and lightweight concrete must conform to Sections 1903 and 1905 of the IBC.

3.4 Steel Deck Panels:

Steel deck panels must be in accordance with the configuration in [Figure 2](#) and have a minimum base steel thickness of 20 gage [0.035 inch (0.899 mm)]. Steel must comply with ASTM A653/A653M SS Grade 50 minimum and have a minimum yield strength of 50,000 psi (345 MPa).

4.0 DESIGN AND INSTALLATION

4.1 Strength Design:

4.1.1 General: Design strength of anchors complying with the 2024 and 2021 IBC as well as Section R301.1.3 of the 2024 and 2021 IRC, must be determined in accordance with ACI 318-19 Chapter 17 and this report.

Design strength of anchors complying with the 2018 and 2015 IBC as well as Section R301.1.3 of the 2018 and 2015 IRC, must be determined in accordance with ACI 318-14 Chapter 17 and this report.

Design strength of anchors complying with the 2012 IBC as well as Section R301.1.3 of the 2012 IRC must be determined in accordance with ACI 318-11 Appendix D and this report.

Design strength of anchors complying with the 2009 IBC and Section R301.1.3 of the 2009 IRC must be determined in accordance with ACI 318-08 Appendix D and this report.

Design parameters provided in this report are based on the 2012 IBC (ACI 318-11) unless noted otherwise in Sections 4.1.1 through 4.1.13. The strength design of anchors must comply with ACI 318 D.4.1, except as required in ACI 318 D.3.3.

Strength reduction factors, ϕ , as given in ACI 318-19 17.5.3, ACI 318-14 17.3.3 and ACI 318-11 D.4.3 for cast-in headed anchors, must be used for load combinations calculated in accordance with Section 1605.1 of the 2024 and 2021 IBC or Section 1605.2 of the 2018, 2015 and 2012 IBC, Section 5.3 of ACI 318-14 and Section 9.2 of ACI 318-11, as applicable. Strength reduction factors, ϕ , as given in ACI 318-11 D.4.4 must be used for load combinations calculated in accordance with ACI 318-11 Appendix C. An example calculation in accordance with the 2012 IBC is provided in [Figure 6](#) of this report. The value of f'_c used in the calculations must be limited to a maximum of 10,000 psi (68.9 MPa), in accordance with ACI 318-19 17.3.1, ACI 318-14 17.2.7 or ACI 318-11 D.3.7, as applicable.

4.1.2 Requirements for Static Steel Strength in Tension: The nominal static steel strength in tension, N_{sa} , of a single anchor must be calculated in accordance with ACI 318-19 17.6.1, ACI 318-14 17.4.1 or ACI 318-11 Section D.5.1, as applicable, for the threaded steel insert element, $N_{sa,rod}$, as illustrated in [Table 3](#) of this report. The lesser of $\phi N_{sa,rod}$ in [Table 3](#) or $\phi N_{sa,insert}$ provided in [Tables 1](#) and [2](#) must be used as the steel strength in tension.

4.1.3 Requirements for Static Concrete Breakout Strength in Tension: The nominal concrete breakout strength of a single anchor or group of anchors in tension, N_{cb} or N_{cbg} , respectively, must be calculated in accordance with ACI 318-19 17.6.2, ACI 318-14 17.4.2 or ACI 318-11 D.5.2, as applicable, for cast-in headed bolts, with modifications as described in this section, and with [Figures 2](#) and [3](#) of this report, as applicable. The basic concrete breakout strength in tension, N_b , must be calculated in accordance with ACI 318-19 17.6.2.2, ACI 318-14 17.4.2.2 or ACI 318-11 D.5.2.2, as applicable, using the values of h_{ef} given in [Tables 1](#) and [2](#), and with $k_c = 24$. The nominal concrete breakout strength in tension in regions where analysis indicates no cracking in accordance with ACI 318-19 17.6.2.5, ACI 318-14 17.4.2.6 or ACI 318-11 D.5.2.6, as applicable, must be calculated with $\psi_{c,N} = 1.25$. For the CRLM installed in the soffit of lightweight or normal-weight concrete filled steel deck assemblies, the contribution of the steel deck strength must be ignored and the calculation of A_{Nc} / A_{Nco} in accordance with ACI 318-19 17.6.2.1, ACI 318-14 17.4.2.1 or ACI 318-11 D.5.2.1, as applicable, and $c_{a,min}$ (minimum edge distance) must be based on [Figures 2](#) and [3](#).

4.1.4 Static Pullout Strength in Tension: The static pullout strength in tension for the CRLW and CRLM inserts does not control design, and need not be calculated.

4.1.5 Requirements for Static Side-Face Blowout Strength in Tension: For the CRLW, the nominal side-face blowout strength of a headed insert, N_{sb} , must be calculated in accordance with ACI 318-19 17.6.4.1, ACI 318-14 17.4.4.1 or ACI 318-11 D.5.4.1, as applicable, for the cast-in headed insert, using the values of A_{brg} as given in [Table 1](#) of this report, as applicable.

For the CRLM metal deck inserts installed in the soffit of lightweight or normal-weight concrete on steel deck floor and roof assemblies as shown in [Figure 2](#), calculation of the concrete side blowout strength is not required.

4.1.6 Requirements for Static Steel Strength in Shear: For the CRLW, the nominal static steel strength of a single anchor in shear, V_{sa} , must be taken as the threaded steel insert element strength, $V_{sa,rod}$, given in [Table 3](#) of this report. The lesser of $\phi V_{sa,rod}$ in [Table 3](#) or $\phi V_{sa,insert}$ in [Table 1](#) must be used as the steel strength in shear, and must be used in lieu of the values derived by calculation from ACI 318-19 Eq. 17.7.1.2a or 17.7.1.2b; ACI 318-14 Eq. 17.5.1.2a or 17.5.1.2b; or ACI 318-11, Eq. D-28 or D-29, as applicable.

For the CRLM, the nominal static steel strength in shear, $V_{sa,deck}$, of a single CRLM insert, in the lower flute and upper flute of concrete filled steel deck assemblies, must be taken as the threaded steel insert element strength, $V_{sa,rod}$, given in [Table 3](#) of this report. The lesser of $\phi V_{sa,rod}$ in [Table 3](#) or $\phi V_{sa,insert,deck}$ in [Table 2](#) shall be used as the steel strength in shear, and must be used in lieu of the values derived by calculation from ACI 318-19 Eq. 17.7.1.2a or 17.7.1.2b; ACI 318-14 Eq. 17.5.1.2a or 17.5.1.2b; or ACI 318-11, Eq. D-28 or D-29, as applicable.

The values given in [Tables 1](#) and [2](#) are for the insert only. Determination of the shear capacity of the threaded rod or other material inserted into the cast-in insert is the responsibility of the design professional. Shear values for common threaded rods are given in [Table 3](#).

4.1.7 Requirements for Static Concrete Breakout Strength in Shear: For the CRLW, the nominal static concrete breakout strength of a single anchor or group of anchors in shear, V_{cb} or V_{cbg} , respectively, must be calculated in accordance with ACI 318-19 17.7.2, ACI 318-14 17.5.2 or ACI 318-11 D.6.2, as applicable. The basic concrete breakout strength, V_b , must be calculated in accordance with ACI 318-19 17.7.2.2, ACI 318-14 17.5.2.2 or ACI 318-11 D.6.2.2, as applicable, based on the values provided in [Table 1](#). The values of $\ell_e (=h_{ef})$ and d_a used in ACI 318-19 Eq. 17.7.2.2.1a, ACI 318-14 Eq. 17.5.2.2a or ACI 318-11 Eq. D-33, as applicable, are provided in [Table 1](#) of this report.

For the CRLM insert installed in the soffit of sand-lightweight or normal-weight concrete on steel deck floor and roof assemblies, as shown in [Figure 2](#) calculation of the concrete breakout strength in shear is not required.

4.1.8 Requirements for Static Concrete Pryout Strength in Shear: For the CRLW inserts, the nominal concrete pryout strength of a single anchor or group of anchors, V_{cp} or V_{cpg} , respectively, must be calculated in accordance with ACI 318-19 17.7.3, ACI 318-14 17.5.3 or ACI 318-11 D.6.3, respectively.

For the CRLM inserts installed in the soffit of lightweight or normal-weight concrete filled steel deck assemblies, as shown in [Figure 2](#), calculation of the concrete pry-out strength in accordance with ACI 318-19 17.7.3, ACI 318-14 17.5.3 or ACI 318-11 D.6.3, as applicable, is not required.

4.1.9 Requirements for Seismic Design:

4.1.9.1 General: For load combinations including seismic, the design must be performed in accordance with ACI 318-19 17.10, ACI 318-14 17.2.3 or ACI 318-11 D.3.3, as applicable. Modifications to ACI 318-19 17.10 or ACI 318-14 17.2.3 shall be applied under Section 1905.7 of the 2024 IBC, Section 1905.1.8 of the 2021, 2018 and 2015 IBC. For the 2012 IBC, Section 1905.1.9 shall be omitted. Modifications to ACI 318 D.3.3 shall be applied under Section 1908.1.9 of the 2009 IBC. The anchors may be installed in Seismic Design Categories A through F of the IBC. The CRLW and CRLM inserts comply with ACI 318-14 2.3 or ACI 318-11 D.1, as applicable, as non-ductile steel elements.

For the CRLW inserts, the nominal steel strength, nominal concrete breakout strength and nominal concrete side-face blowout strength for anchors in tension; and the nominal concrete breakout strength and pryout strength in shear, must be calculated in accordance with ACI 318-19 17.6 and 17.7, ACI 318-14 17.4 and 17.5, or ACI 318-11 D.5 and D.6, as applicable, using the values in [Table 1](#), as applicable.

For the CRLM inserts, the nominal steel strength and nominal concrete breakout strength for anchors in tension; and the nominal concrete breakout strength and pryout strength in the upper flute of concrete filled steel deck assemblies for anchors in shear, must be calculated in accordance with ACI 318-19 17.6 and 17.7, ACI 318-14 17.4 and 17.5, or ACI 318-11 D.5 and D.6, as applicable, using the values in [Table 2](#), as applicable.

4.1.9.2 Seismic Tension: For the CRLW inserts, the nominal steel strength in tension, N_{sa} , of a single anchor must be calculated in accordance with ACI 318-19 17.6.1, ACI 318-14 17.4.1 or ACI 318-11 Section D.5.1, as applicable, for the threaded steel element, $N_{sa,rod,eq}$, as given in [Table 3](#), not to exceed the corresponding values of $N_{sa,insert,eq}$ in [Table 1](#) of this report; the nominal concrete breakout strength for anchors in tension must be calculated in accordance with ACI 318-19 17.6.2, ACI 318-14 17.4.2 or ACI 318-11 D.5.2, as applicable, as described in Section 4.1.3 of this report; the nominal pullout strength need not be considered as noted in Section 4.1.4 of this report; the nominal concrete side-face blowout strength must be calculated in accordance with ACI 318-19 17.6.4.1 and 17.6.4.2, ACI 318-14 17.4.4.1 and 17.4.4.2, or ACI 318-11 D.5.4.1 and D.5.4.2, as applicable, and Section 4.1.5 of this report.

For the CRLM inserts, the nominal steel strength in tension, N_{sa} , of a single anchor must be calculated in accordance with ACI 318-19 17.6.1, ACI 318-14 17.4.1 or ACI 318-11 D.5.1, as applicable, for the threaded steel element, $N_{sa,rod,eq}$, as given in [Table 3](#), not to exceed the corresponding values of $N_{sa,insert,eq}$ in [Table 2](#) of this report; the nominal concrete breakout strength for anchors in tension must be calculated in accordance with ACI 318-19 17.6.2, ACI 318-14 17.4.2 or ACI 318-11 D.5.2, as applicable, as described in Section 4.1.3 of this report; the nominal pullout strength need not be considered as noted in Section 4.1.4 of this report.

4.1.9.3 Seismic Shear: For the CRLW inserts, the nominal concrete breakout strength and pryout strength in shear must be calculated in accordance with ACI 318-19 17.7.2 and 17.7.3, ACI 318-14 17.5.2 and 17.5.3, or ACI 318-11 D.6.2 and D.6.3, as applicable, as described in Sections 4.1.7 and 4.1.8 of this report. In accordance with ACI 318-19 17.7.1.2, ACI 318-14 17.5.1.2 or ACI 318-11 D.6.1.2, as applicable, the nominal steel strength for seismic loads, $V_{sa,eq}$, must be taken as the threaded steel element strength, $V_{sa,rod,eq}$, given in [Table 3](#) of this report, not to exceed the corresponding values of $V_{sa,insert,eq}$, in [Table 1](#).

For the CRLM inserts, the nominal concrete breakout strength and pryout strength in shear is not required. In accordance with ACI 318-19 17.7.1.2, ACI 318-14 17.5.1.2 or ACI 318-11 D.6.1.2, as applicable, the nominal steel strength for seismic loads, $V_{sa,eq}$, must be taken as the threaded steel element strength, $V_{sa,rod,eq}$, given in [Table 3](#) of this report, not to exceed the corresponding values of $V_{sa,insert,deck,eq}$, in [Table 2](#), for lower flute or upper flute of the concrete filled steel deck assembly, as applicable.

4.1.10 Requirements for Interaction of Tensile and Shear Forces: For designs that include combined tension and shear, the interaction of tension and shear loads must be calculated in accordance with ACI 318-19 17.8, ACI 318-14 17.6 or ACI 318-11 D.7, as applicable.

Due to the projection of the internally-threaded end of the CRLM insert when installed in concrete filled steel deck assemblies, for anchors or groups of anchors that are subject to the effects of combined tension and shear forces, the design engineer must take into consideration the effect of bending and verify the validity of the interaction equation in ACI 318-19 17.8, ACI 318-14 17.6 or ACI 318-11 D.7, as applicable.

4.1.11 Requirements for Minimum Member Thickness, h_{min} , Minimum Anchor Spacing, s_{min} , and Minimum Edge Distance, c_{min} : Requirements on headed cast-in specialty anchor edge distance, spacing, member thickness, and concrete strength must be in accordance with the requirements in ACI 318-19 17.9, ACI 318-14 17.7 or ACI 318-11 D.8, as applicable for cast-in bolts.

For the CRLM inserts installed in the soffit of sand-lightweight or normal-weight concrete over profile steel deck floor and roof assemblies, the anchors must be installed in accordance with [Figure 2](#), and shall have a minimum axial spacing along the flute equal to $3h_{ef}$.

4.1.12 Requirements for Critical Edge Distance: The calculation of the critical edge distance, c_{ac} , is not required, since the modification factor $\psi_{cp,N} = 1.0$ for cast-in anchors in accordance with ACI 318-19 17.6.2.6, ACI 318-14 17.4.2.5 or ACI 318-11 D.5.2.5, as applicable.

4.1.13 Lightweight Concrete: For the CRLW in tension in lightweight concrete, the modification factor λ , for concrete breakout strength must be in accordance with ACI 318-19 17.2.4 (2024 and 2021 IBC), ACI 318-14 17.2.6 (2018 and 2015 IBC), ACI 318-11 D.3.6 (2012 IBC), or ACI 318-08 D.3.4 (2009 IBC). For shear, refer to the values of $V_{sa,insert}$ for sand-lightweight concrete in [Table 1](#).

For the CRLM inserts in the soffit of sand-lightweight concrete-filled steel deck, this reduction is not required. Values shown in [Table 2](#) are based on use in sand-lightweight concrete and are also valid for normal weight concrete. Installation details are shown in [Figure 2](#).

4.2 Allowable Stress Design (ASD):

4.2.1 General: Design values for use with allowable stress design (working stress design) load combinations calculated in accordance with Section 1605.1 of the 2024 and 2021 IBC, Section 1605.3 of the 2018, 2015 and 2012 IBC, must be established as follows:

$$T_{allowable,ASD} = \frac{\phi N_n}{\alpha}$$

$$V_{allowable,ASD} = \frac{\phi V_n}{\alpha}$$

where:

$T_{allowable,ASD}$ = Allowable tension load (lbf or kN).

$V_{allowable,ASD}$ = Allowable shear load (lbf or kN).

ϕN_n = Lowest design strength of an anchor or anchor group in tension as determined in accordance with ACI 318-19 17.5 or ACI 318-14 17.3.1 and 2024 IBC Section 1905.7 or 2021, 2018 and 2015 IBC Section 1905.1.8, ACI 318-11, -08 D.4.1, and 2009 IBC Section 1908.1.9, as applicable (lbf or N).

ϕV_n = Lowest design strength of an anchor or anchor group in shear as determined in accordance with ACI 318-19 17.5, ACI 318-14 17.3.1 and 2024 IBC Section 1905.7 or 2021, 2018 and 2015 IBC Section 1905.1.8, ACI 318-11, -08 D.4.1, and 2009 IBC Section 1908.1.9, as applicable (lbf or N).

α = Conversion factor calculated as a weighted average of the load factors for the controlling load combination. In addition, α must include all applicable factors to account for non-ductile failure modes and required over-strength.

The requirements for member thickness, edge distance and spacing, described in this report, must apply. Examples of allowable stress design value determination for illustrative purposes are shown in [Table 4](#).

4.2.2 Interaction of Tensile and Shear Forces: For designs that include combined tension and shear, the interaction of tension and shear loads must be calculated in accordance with ACI 318-19 17.8, ACI 318-14

17.6 or ACI 318-11 D.7, as applicable, as follows:

For shear loads $V_{applied} \leq 0.2V_{allowable,ASD}$, the full allowable load in tension must be permitted.

For tension loads $T_{applied} \leq 0.2T_{allowable,ASD}$, the full allowable load in shear must be permitted.

For all other cases:

$$\frac{T_{applied}}{T_{allowable,ASD}} + \frac{V_{applied}}{V_{allowable,ASD}} \leq 1.2 \quad (\text{Eq-1})$$

Due to the projection of the internally-threaded end of the CRLM insert when installed in concrete filled steel deck assemblies, for anchors or groups of anchors that are subject to the effects of combined tension and shear forces, the design engineer must take into consideration the effect of bending and verify the validity of the interaction equation in ACI 318-19 17.8, ACI 318-14 17.6 or ACI 318-11 D.7, as applicable.

4.3 Installation:

For the CRLW inserts, installation parameters are provided in [Table 1](#) and in [Figures 1](#) and [4](#). CRLW inserts must be assembled to the wood form using a hammer to drive the nails into the form prior to concrete placement. Following concrete placement and removal of formwork, remove protruding nails by shearing off with a hammer. From beneath the deck, insert the correct size threaded rod into the CRLW insert. Push in threaded rod until bottomed out without rotation of threaded rod. It is not required to tighten threaded rod inside CRLW insert, but this is acceptable.

For the CRLM inserts, installation parameters are provided in [Table 2](#) and in [Figures 2](#) and [5](#). A hole must be cut in the steel deck using a metal hole saw in accordance with the corresponding hole diameters shown in [Table 2](#). From the topside of the deck, assemble the CRLM insert into the hole in the decking using a hammer. Ensure that the CRLM insert is straight vertically with the correct height. Following concrete placement and hardening, push in threaded rod from the underside of the deck until bottomed out without rotation of threaded rod. It is not required to tighten threaded rod inside CRLM insert, but this is acceptable. The plastic sleeve must be cut and trimmed to the surface of the insert following the concrete pour if the insert is intended to resist shear loads. CRLM inserts are permitted to be installed in either the upper or lower flute of the steel deck.

Installation of CRLW and CRLM inserts must be in accordance with this evaluation report and the manufacturer's published installation instruction (MPII) as provided in [Figures 4](#) and [5](#) of this report. In the event of a conflict between this report and the MPII, this report governs.

4.4 Special Inspection:

Periodic special inspection is required in accordance with Section 1705.1.1 and Table 1705.3 of the 2024, 2021, 2018, 2015 or 2012 IBC, or Section 1704.15 and Table 1704.4 of the 2009 IBC, as applicable. The special inspector must make periodic inspections during installation of the headed cast-in specialty inserts to verify insert type, insert dimensions, concrete type, concrete compressive strength, insert spacing, edge distances, concrete member thickness, insert embedment, threaded rod fully seated into insert, and adherence to the manufacturer's printed installation instructions. The special inspector must be present as often as required in accordance with the "statement of special inspection." Under the IBC, additional requirements as set forth in Sections 1705, 1706 and 1707 must be observed, where applicable.

5.0 CONDITIONS OF USE:

The CRLW and CRLM concrete inserts described in this report are acceptable alternatives to what is specified in the codes listed in Section 1.0 of this report, subject to the following conditions:

- 5.1 Specialty inserts are limited to dry interior locations.
- 5.2 Specialty insert sizes, dimensions, minimum embedment depths, and other installation parameters are as set forth in this report.
- 5.3 Specialty inserts must be installed in accordance with the manufacturer's printed installation instructions (MPII) and this report. In case of conflict, this report governs.
- 5.4 Specialty inserts must be limited to use in cracked and uncracked normal-weight concrete, and lightweight concrete having a specified compressive strength, f'_c , of 2,500 psi to 10,000 psi (17.2 MPa to 68.9 MPa) for the CRLW inserts, and in cracked and uncracked normal-weight or sand-lightweight concrete filled steel deck assemblies having a specified compressive strength, f'_c , of 3,000 psi to 10,000 psi (20.7 MPa to 68.9 MPa) for the CRLM inserts.
- 5.5 The values of f'_c used for calculation purposes must not exceed 10,000 psi (68.9 MPa).
- 5.6 Strength design values must be established in accordance with Section 4.1 of this report.

- 5.7 Allowable design values are established in accordance with Section 4.2.
- 5.8 Specialty insert spacing and edge distance as well as minimum member thickness must comply with ACI 318-19 17.9, ACI 318-14 17.7 or ACI 318-11 D.8 requirements, as applicable, for cast-in-place headed anchors, and [Table 1](#) and [Table 2](#), and [Figure 1](#) and [2](#) of this report.
- 5.9 Prior to installation, calculations and details demonstrating compliance with this report must be submitted to the code official. The calculations and details must be prepared by a registered design professional where required by the statutes of the jurisdiction in which the project is to be constructed.
- 5.10 Since an ICC-ES acceptance criteria for evaluating data to determine the performance of the specialty inserts subjected to fatigue or shock loading is unavailable at this time, the use of these inserts under such conditions is beyond the scope of this report.
- 5.11 Specialty inserts may be installed in regions of concrete where analysis indicates cracking may occur ($f_t > f_{cr}$), subject to the conditions of this report.
- 5.12 Specialty inserts may be used to resist short-term loading due to wind or seismic forces in locations designated as Seismic Design Categories A through F of the IBC, subject to the conditions of this report.
- 5.13 Where not otherwise prohibited in the code, inserts are permitted for use with fire-resistance-rated construction provided that at least one of the following conditions is fulfilled:
- Headed cast-in specialty inserts that support a fire-resistance-rated envelope or a fire-resistance-rated membrane are protected by approved fire-resistance-rated materials, or have been evaluated for resistance to fire exposure in accordance with recognized standards.
 - Headed cast-in specialty inserts are used to resist wind or seismic forces only.
 - Headed cast-in specialty inserts are used to support nonstructural elements.
- 5.14 Special inspection must be provided in accordance with Section 4.4.
- 5.15 Specialty inserts are manufactured under an approved quality control program with inspections by ICC-ES.

6.0 EVIDENCE SUBMITTED

- 6.1 Data in accordance with the [ICC-ES Acceptance Criteria for Headed Cast-in Specialty Inserts in Concrete \(AC446\)](#), dated August 2018 (editorially revised April 2024).
- 6.2 Quality-control documentation.

7.0 IDENTIFICATION

- 7.1 The CRLW and CRLM inserts are identified by packaging labeled with the manufacturer's name (Erico International Corporation, a division of nVent) and contact information, insert name, insert size, lot number and evaluation report number (ESR-3864).
- 7.2 The report holder's contact information is the following:

**ERICO INTERNATIONAL CORPORATION,
A DIVISION OF NVENT
31700 SOLON ROAD
SOLON, OHIO 44139
(440) 248-0100
www.erico.com**

TABLE 1—CADDY CRLW CAST-IN INSERT DESIGN AND INSTALLATION INFORMATION^{1,2,3,4,5,6,7}

DESIGN INFORMATION	SYMBOL	UNITS	Nominal anchor diameter (in.)	
			³ / ₈	¹ / ₂
Insert thread size	<i>d</i>	UNC	³ / ₈ -16	¹ / ₂ -13
Insert steel characterization	-	-	Non-Ductile	
Effective embedment	<i>h_{ef}</i>	in. (mm)	1.89 (48.0)	1.89 (48.0)
Outside anchor diameter	<i>d_a</i>	in. (mm)	0.61 (15.5)	0.71 (18.0)
Bearing area	<i>A_{brg}</i>	in. ² (mm ²)	0.79 (510)	0.87 (560)
Minimum member thickness	<i>h_{min}</i>	in. (mm)	3.25 (83)	3.25 (83)
Minimum spacing	<i>s_{min}</i>	in. (mm)	8 (203)	
Minimum edge distance	<i>c_{min}</i>	in. (mm)	6 (152)	
Effectiveness factor concrete breakout ⁴	<i>k_c</i>	-	24	
Modification factor for tension in uncracked concrete	<i>ψ_{c,N}</i>	-	1.25	
Nominal steel strength in tension as governed by the insert ²	<i>N_{sa,insert}</i>	lb (kN)	5,465 (24.3)	11,040 (49.1)
Nominal seismic steel strength in tension as governed by the insert ²	<i>N_{sa,insert,eq}</i>	lb (kN)	4,920 (21.9)	11,040 (49.1)
Strength reduction factor φ for tension, steel failure of insert	φ	-	0.65	
Strength reduction factor φ for tension, concrete failure modes, Condition B ⁵	φ	-	0.70	
Concrete pullout, uncracked	<i>N_{p,uncr}</i>	-	N/A	
Concrete pullout, cracked	<i>N_{p,cr}</i>	-	N/A	
Nominal steel strength in shear as governed by the insert, sand-lightweight concrete ²	<i>V_{sa,insert}</i>	lb (kN)	2,590 (11.5)	6,035 (26.8)
Nominal seismic steel strength in shear as governed by the insert, sand-lightweight concrete ²	<i>V_{sa,insert,eq}</i>	lb (kN)	2,590 (11.5)	6,035 (26.8)
Nominal steel strength in shear as governed by the insert, normal-weight concrete ²	<i>V_{sa,insert}</i>	lb (kN)	4,065 (18.1)	9,085 (40.4)
Nominal seismic steel strength in shear as governed by the insert, normal-weight concrete ²	<i>V_{sa,insert,eq}</i>	lb (kN)	4,065 (18.1)	9,085 (40.4)
Coefficient for pryout strength	<i>k_{cp}</i>	-	1.0	
Strength reduction factor φ for shear, steel failure of insert	φ	-	0.60	
Strength reduction factor φ for shear, concrete failure modes, Condition B ⁵	φ	-	0.70	

For SI: 1 inch = 25.4 mm. For pound-inch units: 1 mm = 0.03937 inch.

¹Installation must comply with Section 4.3 and Figures 1 and 4 of this report.

²The design strength must be in accordance with ACI 318 (-19 or -14) Chapter 17 or ACI 318-11 Appendix D, as applicable, and Section 4.1 of this report. Values are for the insert only. The capacity of the threaded rod or other material threaded into the insert must also be determined. See Table 3 for steel design information for common threaded rod elements.

³See ACI 318-19 17.5.3, ACI 318-14 17.3.3 or ACI 318-11 D.4.3, as applicable.

⁴See ACI 318-19 17.6.2.2, ACI 318-14 17.4.2.2 or ACI 318-11 D.5.2.2, as applicable.

⁵For use with load combinations of ACI 318 (-19 and -14) Section 5.3 or ACI 318-11 Section 9.2, as applicable. Condition B applies where supplementary reinforcement in conformance with ACI 318-19 17.5.3, ACI 318-14 17.3.3 or ACI 318-11 D.4.3, as applicable, is not provided. For cases where supplementary reinforcement can be verified, the strength reduction factors associated with Condition A may be used.

⁶Inserts must be installed in concrete with a minimum compressive strength *f*'_c of 2,500 psi.

⁷The design professional is responsible for checking threaded rod or bolt strength in tension, shear, and combined tension and shear, as applicable.

TABLE 2—CADDY CRLM CAST-IN INSERT DESIGN AND INSTALLATION INFORMATION^{1,2,3,4,5,6,7}

DESIGN INFORMATION	SYMBOL	UNITS	Nominal anchor diameter (in.)	
			³ / ₈	¹ / ₂
Insert thread size	d	UNC	³ / ₈ -16	¹ / ₂ -13
Effective Embedment	h_{ef}	in. (mm)	1.82 (46.3)	1.82 (46.3)
Metal hole saw diameter	d_{hole}	in. (mm)	³ / ₄ (19)	⁷ / ₈ (22)
Min. offset from lower flute edge ³	-	in. (mm)	¹ / ₈ (29)	
Insert steel characterization	-	-	Non-Ductile	
Outside anchor diameter	d_a	in. (mm)	0.61 (15.5)	0.71 (18.0)
Bearing area	A_{brg}	in. ² (mm ²)	0.70 (448)	0.76 (490)
Minimum concrete cover above upper flute	h_{min}	in. (mm)	3.25 (83)	3.25 (83)
Minimum spacing and edge distance ⁸	$S_{min}; C_{min}$	in. (mm)	See Figure 2	
Effectiveness factor concrete breakout ⁵	k_c	-	24	
Modification factor for tension in uncracked concrete	$\psi_{c,N}$	-	1.25	
Nominal steel strength in tension as governed by the insert ²	$N_{sa,insert}$	lb (kN)	4,855 (21.6)	10,230 (45.5)
Nominal seismic steel strength in tension as governed by the insert ²	$N_{sa,insert,eq}$	lb (kN)	4,855 (21.6)	10,230 (45.5)
Strength reduction factor ϕ for tension, steel failure of insert	ϕ	-	0.65	
Strength reduction factor ϕ for tension, concrete failure modes, Condition B ⁶	ϕ	-	0.70	
Concrete pullout, uncracked	$N_{p,uncr}$	-	N/A	
Concrete pullout, cracked	$N_{p,cr}$	-	N/A	
Nominal steel strength in shear as governed by the insert installed in lightweight concrete filled metal deck ²	$V_{sa,deck}$	lb (kN)	1,445 (6.4)	3,295 (14.7)
Nominal seismic steel strength in shear as governed by the insert installed in lightweight concrete filled metal deck ²	$V_{sa,deck,eq}$	lb (kN)	1,445 (6.4)	3,295 (14.7)
Coefficient for pryout strength	k_{cp}	-	1.0	
Strength reduction factor ϕ for shear, steel failure of insert	ϕ	-	0.60	
Strength reduction factor ϕ for shear, concrete failure modes, Condition B ⁶	ϕ	-	0.70	

For SI: 1 inch = 25.4 mm. For pound-inch units: 1 mm = 0.03937 inch.

¹Installation must comply with Section 4.3 and [Figures 2](#) and [5](#) of this report.

²The design strength must be in accordance with ACI 318 (-19 or -14) Chapter 17 or ACI 318-11 Appendix D, as applicable, and Section 4.1 of this report. Values are for the insert only. The capacity of the threaded rod or other material threaded into the insert must also be determined. See [Table 3](#) for steel design information for common threaded rod elements.

³Inserts in the lower flute may be installed with a maximum offset of ¹/₈ inch in either direction from the centerline of the flute.

⁴See ACI 319-19 17.5.3, ACI 318-14 17.3.3 or ACI 318-11 D.4.3, as applicable.

⁵See ACI 318-19 17.6.2.2, ACI 318-14 17.4.2.2 or ACI 318-11 D.5.2.2, as applicable.

⁶For use with load combinations of ACI 318 (-19 and -14) Section 5.3 or ACI 318-11 Section 9.2, as applicable. Inserts must be installed in concrete with a minimum compressive strength f'_c of 3,000 psi.

⁷The design professional is responsible for checking threaded rod or bolt strength in tension, shear, and combined tension and shear, as applicable.

⁸Axial spacing parallel to the flute direction shall be $3h_{ef}$ minimum. See [Figure 2](#) for additional spacing and edge distance requirements.

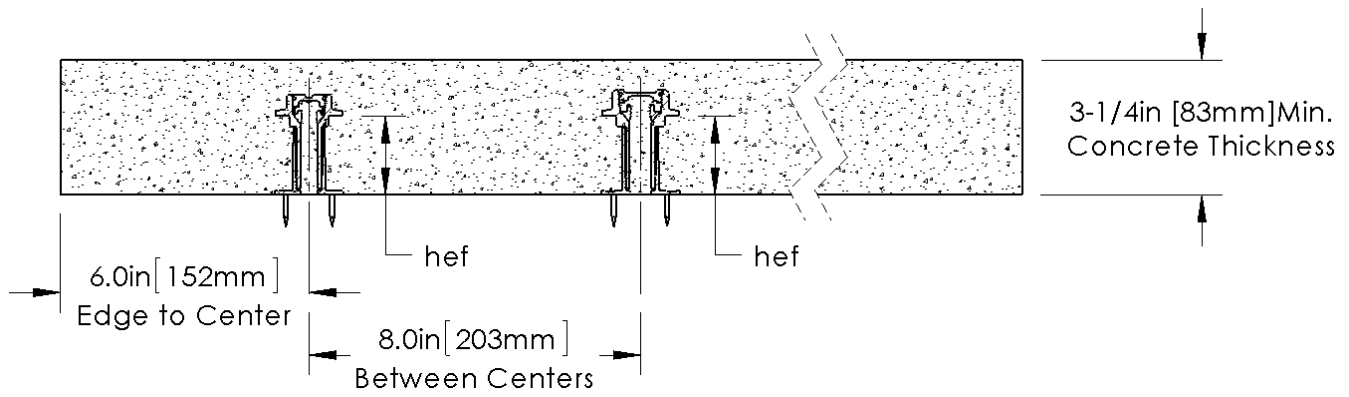

FIGURE 1—CADDY CRLW INSERT IN CONCRETE

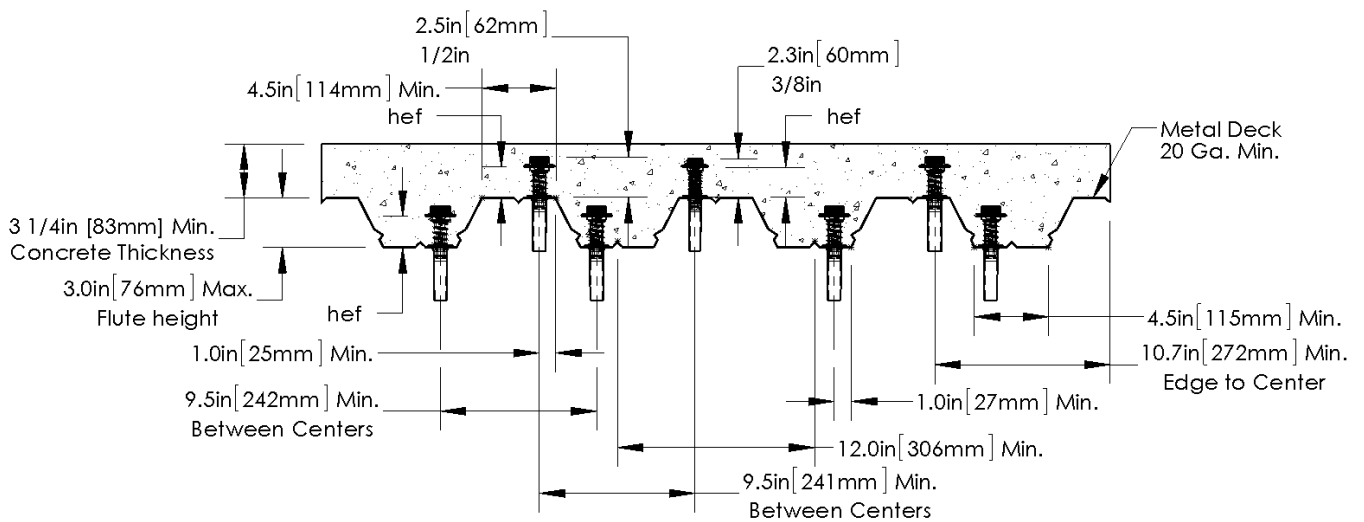

FIGURE 2—CADDY CRLM INSERT INSTALLED IN SOFFIT OF CONCRETE FILLED STEEL DECK FLOOR AND ROOF ASSEMBLIES^{1,2}

¹Anchors may be placed in the upper or lower flute of the steel deck profile provided the minimum clearance is satisfied. Anchors in the lower flute may be installed with a min 1-inch offset from the edge of the flute.

²Axial spacing along the flute length shall be minimum $3h_{ef}$.

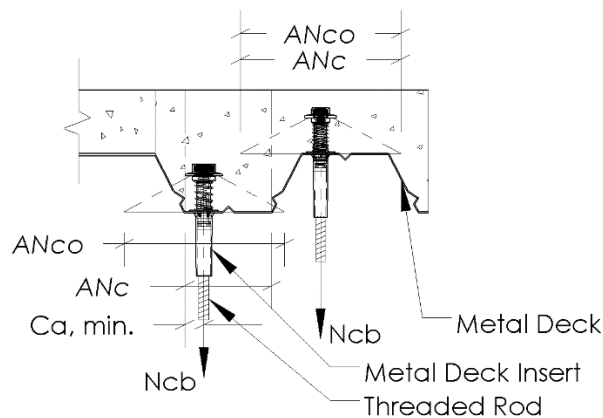

FIGURE 3—IDEALIZATION OF CONCRETE FILLED STEEL DECKS FOR DETERMINATION OF CONCRETE BREAKOUT STRENGTH IN ACCORDANCE WITH ACI 318

TABLE 3—STEEL DESIGN INFORMATION FOR COMMON THREADED ROD ELEMENTS USED WITH CADDY CRLW AND CRLM CONCRETE INSERTS^{1,2,3,4}

DESIGN INFORMATION	SYMBOL	UNITS	3/8-inch	1/2-inch
Threaded rod nominal outside diameter	d_{rod}	in. (mm)	0.375 (9.5)	0.500 (12.7)
Threaded rod effective cross-sectional area	A_{se}	in ² (mm ²)	0.078 (50)	0.142 (92)
Nominal tension strength of ASTM A36 threaded rod in tension as governed by steel strength for static or seismic loading	$N_{sa,rod,A36}$ Or $N_{sa,rod,eq,A36}$	lb (kN)	4,525 (20.0)	8,235 (36.6)
Nominal shear strength of ASTM A36 threaded rod in shear as governed by steel strength for static loading	$V_{sa,rod,A36}$	lb (kN)	2,695 (12.0)	4,490 (22.0)
Nominal shear strength of ASTM A36 threaded rod in shear as governed by steel strength for seismic loading	$V_{sa,rod,eq,A36}$	lb (kN)	1,900 (8.4)	3,460 (15.4)

For SI: 1 inch = 25.4 mm, 1 pound = 0.00445 kN, 1 in² = 645.2 mm². For pound-inch unit: 1 mm = 0.03937 inches.

¹Values provided for steel element material types, or equivalent, based on minimum specified strength; $N_{sa,rod}$ and $V_{sa,rod}$ calculated in accordance with ACI 318-19 Eq. 17.6.1.2 and 17.7.1.2b, ACI 318-14 Eq. (17.4.1.2) and Eq. (17.5.1.2b) or ACI 318-11 Eq. (D-2) and Eq. (D-29) respectively. $V_{sa,rod,eq}$ must be taken as $0.7 V_{sa,rod}$. Materials of other strengths may be used and calculated in a similar manner.

² ϕN_{sa} shall be the lower of the $\phi N_{sa,rod}$ or $\phi N_{sa,insert}$ for static steel strength in tension; for seismic loading $\phi N_{sa,eq}$ shall be the lower of the $\phi N_{sa,rod,eq}$ or $\phi N_{sa,insert,eq}$.

³ ϕV_{sa} shall be the lower of the $\phi V_{sa,rod}$ or $\phi V_{sa,insert}$ for static steel strength in tension; for seismic loading $\phi V_{sa,eq}$ shall be the lower of the $\phi V_{sa,rod,eq}$ or $\phi V_{sa,insert,eq}$.

⁴Strength reduction factors shall be taken from ACI 318-19 17.5.3, ACI 318-14 17.3.3 or ACI 318-11 D.4.3, as applicable, for steel elements. Strength reduction factors for load combinations in accordance with ACI 318 (-19 and -14) Section 5.3 or ACI 318-11 Section 9.2, as applicable, governed by steel strength of ductile steel elements shall be taken as 0.75 for tension and 0.65 for shear. If the load combinations of ACI 318-11 Appendix C are used, the appropriate value of ϕ must be determined in accordance with ACI 318-11 D.4.4.

TABLE 4—EXAMPLE ASD ALLOWABLE TENSION AND SHEAR DESIGN VALUES FOR ILLUSTRATIVE PURPOSES FOR CADDY CRLW INSERTS INSTALLED IN NORMAL WEIGHT CONCRETE AND CRLM INSERTS INSTALLED IN LIGHTWEIGHT CONCRETE OVER METAL DECK FLOOR AND ROOF ASSEMBLIES^{1,2,3,4,5,6,7,8,9}

Nominal Insert Diameter (inches)	CRLW		CRLM			
			W-Deck Installation			
			Upper Flute		Lower Flute	
	Tension (lbs)	Shear (lbs)	Tension (lbs)	Shear (lbs)	Tension (lbs)	Shear (lbs)
3/8	1,845	1,647	1,300	585	945	585
1/2	1,845	3,685	1,300	1,335	945	1,335

For SI: 1 inch = 25.4 mm, 1 pound = 0.00445 kN, 1 in² = 645.2 mm². For pound-inch unit: 1 mm = 0.03937 inches.

¹Concrete strength f'_c = 2500 psi normal weight for CRLW; f'_c = 3000 psi lightweight for CRLM.

²Values are for single anchors with static tension or shear. Installation must be in accordance with applicable Figures 1 and 2.

³Values are for uncracked concrete.

⁴Load combinations as given in ACI 318 (-19 and -14) Section 5.3 or ACI 318-11 Section 9.2, as applicable (no seismic loading).

⁵30% dead load and 70% live load, controlling load combination 1.2D + 1.6 L.

⁶Calculation of ASD conversion $\alpha = 0.3 \cdot 1.2 + 0.7 \cdot 1.6 = 1.48$

⁷Values assume no side-face blowout in tension for CRLW or for CRLM.

⁸Values are for Condition B where supplementary reinforcement in accordance with ACI 318-19 17.5.3, ACI 318-14 17.3.3 or ACI 318-11 D.4.3, as applicable, is not provided.

⁹The allowable loads shown are for the applicable insert only. Design professional is responsible for checking capacity of threaded rod, including tension, shear, and influence of bending on tension capacity when loaded in shear, or other material placed in insert.

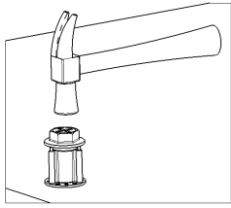

1. Assemble CRLW insert to wood form using a hammer.

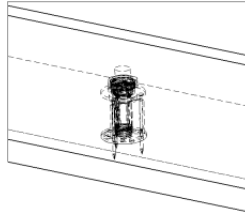

2. Pour concrete into wood form.

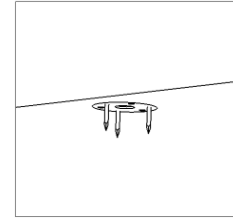

3. After concrete is cured, remove wood form.

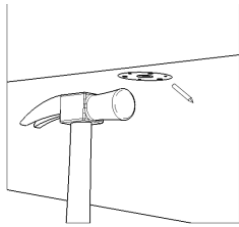

4. Remove protruding nails by shearing off with a hammer.

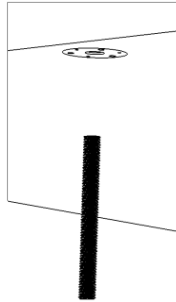

5. Insert the correct size of threaded rod into the CRLW insert.

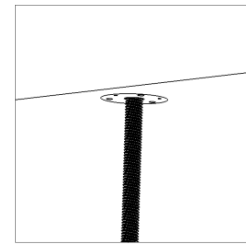

6. Push in threaded rod until bottomed out without rotation of threaded rod. It is not required to tighten threaded rod inside CRLW insert, but this is acceptable.

FIGURE 4—CADDY CRLW CONCRETE INSERT INSTALLATION INSTRUCTIONS (MPII)

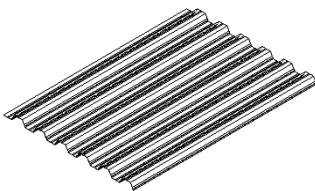

1. Assemble the necessary metal decking.

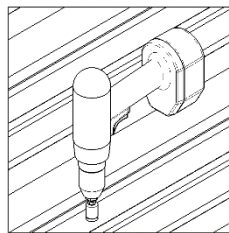

2. Cut a hole using a metal hole saw sized appropriate for the CRLM insert. For 3/8" inserts, cut 3/4" (19 mm) diameter. For 1/2" inserts, cut 7/8" (22 mm) diameter.

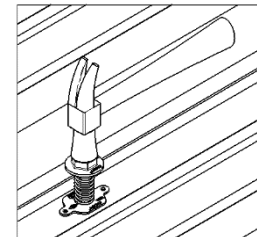

3. Assemble CRLM insert into the hole in the decking using a hammer. Ensure that the CRLM insert is straight vertically with the correct height.

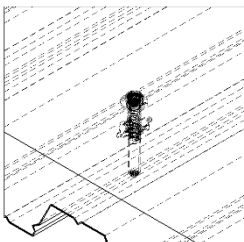

4. Pour concrete over decking and CRLM insert.

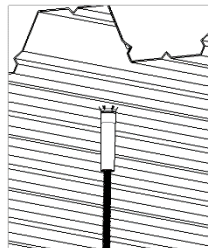

5. Push in threaded rod until bottomed out without rotation of threaded rod. It is not required to tighten threaded rod inside CRLM insert, but this is acceptable.

FIGURE 5—CADDY CRLM CONCRETE INSERT INSTALLATION INSTRUCTIONS (MPII)

		<p>Given: One ½ inch CADDY CRLW anchor with an edge distance of 7 inches and spacing of 10 inches, loaded in tension. $h_{ef} = 1.89$ in No supplementary reinforcement Condition B per ACI 318-19 17.5.3, ACI 318-14 17.3.3 c) or ACI 318-11 D.4.3 c) Assume normal weight concrete, $f_c = 2,500$ psi Assume uncracked concrete ASTM A36 attached steel rod insert element</p> <p>Using strength design provisions of ACI 318 (-19 or -14) Chapter 17, or ACI 318-11 Appendix D, calculate the nominal tensile strength and allowable stress design capacity for this configuration. For ASD, given 30% dead load and 70% live load, controlling load combination 1.2D + 1.6 L, calculation of ASD conversion $\alpha = 0.3*1.2 + 0.7*1.6 = 1.48$</p>		
Calculations per ACI 318- and this report.		ACI 318-19 Chapter 17	ACI 318-14 Chapter 17	ACI 318-11 Appendix D
<p>Step 1. Calculate steel tensile capacity. $N_{sa,insert} = \rightarrow$ Given in Table 1 $N_{sa,insert} = 11,040$ lb. $\phi N_{sa,insert} = (0.65) 11,040$ lb. $\phi N_{sa,insert} = \mathbf{7,176}$ lb. $N_{sa,rod,A36} = A_{se} f_{uta} \rightarrow$ Given in Table 3 $N_{sa,rod,A36} = 8,235$ lb. $\phi N_{sa,rod,A36} = (0.75) 8,235$ lb. $\phi N_{sa,rod,A36} = \mathbf{6,176}$ lb.</p>		17.6.1	17.4.1	D.5.1
<p>Step 2. Calculate concrete breakout of anchor in tension. $N_{cb} = N_b (A_{Nc}/A_{Nco}) \psi_{ed,N} \psi_{c,N} \psi_{cp,N}$</p>		17.6.2 a)	17.4.2.1 a)	D.5.2.1 a)
<p>Step 2a. Check spacing and edge distance requirements. \rightarrow Given in Table 1 $c_{min} = 7$ in > 6 in $s_{min} = 10$ in ≤ 8 in \rightarrow okay spacing and edge distance</p>		17.9	17.7	D.8
<p>Step 2b. Determine λ; normal weight concrete; $\lambda = 1.0$</p>		17.10	17.2.6	D.3.6
<p>Step 2c. Calculate basic concrete breakout strength in tension. $N_b = 24 \lambda \sqrt{f_c} (h_{ef})^{1.5}$ $N_b = 24(1.0) \sqrt{2,500} (1.89)^{1.5}$ $N_b = 3,118$ lb</p>		17.6.2.2	17.4.2.2	D.5.2.2
<p>Step 2d. Determine ratio of projected concrete breakout areas. Single anchor, $c_{min} = 7$ in $> 1.5 h_{ef} = 2.84$ $A_{Nc} = A_{Nco} = 32.15$ in²; $A_{Nc} / A_{Nco} = 1.0$</p>		17.6.2.3	17.4.2.3	D.5.2.3
<p>Step 2e. Determine $\psi_{ec,N}$. No eccentricity $\psi_{ec,N} = 1.0$</p>		17.6.2.4	17.4.2.4	D.5.2.4
<p>Step 2f. Determine $\psi_{ed,N}$. $c_{min} = 7$ in $> 1.5 h_{ef} = 2.84$ $\psi_{ed,N} = 1.0$</p>		17.6.2.5	17.4.2.5	D.5.2.5
<p>Step 2g. Determine $\psi_{c,N}$. uncracked concrete $\rightarrow \psi_{c,N} = 1.25$</p>		17.6.2.6	17.4.2.6	D.5.2.6
<p>Step 2j. Calculate ϕN_{cb}. $\phi N_{cb} = 0.70 * 3,118 * \frac{32.15}{32.15} * 1.0 * 1.25 * 1.0$ $\phi N_{cb} = \mathbf{2,728}$ lb</p>		17.5.3 c) 17.6.2.1 a)	17.3.3 c) 17.4.2.1 a)	D.4.3 c) D.5.2.1 a)
<p>Step 3. Check pullout strength of concrete in tension. $N_{pN} = \psi_{c,p} N_p$; Table 1 – Pullout strength does not govern.</p>		17.6.3.1	17.4.3.1	D.5.3.1
<p>Step 4. Calculate concrete side face blowout. $h_{ef} < 2.5c_a \rightarrow$ not applicable</p>		17.6.4.2	17.4.4.1	D.5.4.1
<p>Step 5. Determine the controlling tensile strength. <i>Steel insert strength</i> $\phi N_{sa,insert} = 7,176$ lb <i>Steel insert element strength</i> $\phi N_{sa,rod,A36} = 6,176$ lb <i>Concrete breakout strength</i> $\phi N_{cb} = \mathbf{2,728}$ lb CONTROLS</p>		17.5.1.2	17.3.1	D.4.1
<p>Step 6. Determine allowable stress design capacity using load conditions given above: $T_{allowable,ASD} = \phi N_n / \alpha = 2,728 / 1.48 = \mathbf{1,843}$ lb</p>		ESR Section 4.2	ESR Section 4.2	ESR Section 4.2

FIGURE 6—DESIGN EXAMPLE FOR CADDY CRLW

DIVISION: 03 00 00—CONCRETE
Section: 03 15 19—Cast-in Concrete Anchors
Section: 03 16 00—Concrete Anchors

REPORT HOLDER:

ERICO INTERNATIONAL CORPORATION, A DIVISION OF NVENT

EVALUATION SUBJECT:

CADDY ROD LOCK PLYWOOD FORM (CRLW) AND CADDY ROD LOCK METAL DECKING (CRLM) HEADED CAST-IN SPECIALTY INSERTS IN CRACKED AND UNCRACKED CONCRETE

1.0 REPORT PURPOSE AND SCOPE**Purpose:**

The purpose of this evaluation report supplement is to indicate that CADDY ROD LOCK Plywood Form (CRLW) AND CADDY ROD LOCK Metal Decking (CRLM) Headed Cast-In Special Inserts in Cracked and Uncracked Concrete, described in ICC-ES evaluation report ESR-3864, have also been evaluated for compliance with the codes noted below.

Applicable code editions:

- 2022 and 2019 *California Building Code (CBC)*

For evaluation of applicable chapters adopted by the California Office of Statewide Health Planning and Development (OSHPD) AKA: California Department of Health Care Access and Information (HCAI) and the Division of State Architect (DSA), see Sections 2.1.1 and 2.1.2 below.

- 2022 and 2019 *California Residential Code (CRC)*

2.0 CONCLUSIONS**2.1 CBC:**

The CADDY ROD LOCK Plywood Form (CRLW) AND CADDY ROD LOCK Metal Decking (CRLM) Headed Cast-In Special Inserts in Cracked and Uncracked Concrete, described in Sections 2.0 through 7.0 of the evaluation report ESR-3864, comply with CBC Chapter 19, provided the design and installation are in accordance with the 2021 and 2018 *International Building Code*® (IBC) provisions noted in the evaluation report and the additional requirements of CBC Chapters 16, 17 and 19, as applicable.

2.1.1 OSHPD:

The applicable OSHPD Sections and Chapters of the CBC are beyond the scope of this supplement.

2.1.2 DSA:

The applicable DSA Sections and Chapters of the CBC are beyond the scope of this supplement.

2.2 CRC:

The CADDY ROD LOCK Plywood Form (CRLW) AND CADDY ROD LOCK Metal Decking (CRLM) Headed Cast-In Special Inserts in Cracked and Uncracked Concrete, described in Sections 2.0 through 7.0 of the evaluation report ESR-3864, comply with CRC Section R301.1.3, provided the design and installation are in accordance with the 2021 and 2018 *International Residential Code*® (IRC) provisions noted in the evaluation report and the additional requirements of CRC Section R301.1.3.

This supplement expires concurrently with the evaluation report, reissued May 2024 and revised July 2024.