

# ICC-ES Evaluation Report

**ESR-3847**

Reissued May 2023

This report also contains:

Revised July 2024

- LABC Supplement

Subject to renewal May 2025

- FBC Supplement

ICC-ES Evaluation Reports are not to be construed as representing aesthetics or any other attributes not specifically addressed, nor are they to be construed as an endorsement of the subject of the report or a recommendation for its use. There is no warranty by ICC Evaluation Service, LLC, express or implied, as to any finding or other matter in this report, or as to any product covered by the report.

Copyright © 2024 ICC Evaluation Service, LLC. All rights reserved.

<p><b>DIVISION: 06 00 00—</b> <b>WOOD, PLASTICS AND</b> <b>COMPOSITES</b></p> <p><b>Section: 06 05 23—</b> <b>Wood, Plastic, and</b> <b>Composite Fastenings</b></p>	<p><b>REPORT HOLDER:</b> <b>MITEK® INC.</b></p> 	<p><b>EVALUATION SUBJECT:</b> <b>MITEK HOLD-DOWNS</b> <b>AND TENSION TIES</b></p>	
--	---	---	---

## 1.0 EVALUATION SCOPE

**Compliance with the following codes:**

- 2024, 2021, 2018, 2015 and 2012 [International Building Code® \(IBC\)](#)
- 2024, 2021, 2018, 2015 and 2012 [International Residential Code \(IRC\)](#)

For evaluation for compliance with codes adopted by the [Los Angeles Department of Building and Safety \(LADBS\)](#), see [ESR-3847 LABC and LARC Supplement](#).

**Property evaluated:**

- Structural

## 2.0 USES

MiTek HTT Series Tension Tie hold-downs include the HTT16 and HTT45 tension tie hold-downs. The HTT16 and HTT45 are used to connect wood members to concrete foundations, in accordance with applicable sections of the IBC and IRC, as well as applicable sections of the ANSI AWC SDPWS (Special Design Provisions for Wind and Seismic). The HTT16 and HTT45 tension tie hold-downs may also be used in structures regulated under the IRC, when an engineered design is submitted in accordance with Section R301.1.3 of the IRC; or when used in accordance with the applicable prescriptive provisions of the IRC.

The ADTT-TZ Adjustable Deck Tension Tie is a deck anchor that connects deck joists directly to the upper double top plate of an exterior wall in accordance with Section R507.9.2 of the 2024, 2021 and 2018 IRC [Figure R507.9.2(2)] {R507.2.4 of the 2015 IRC [Figure R507.2.3(2)]} and is used to transfer short term lateral tension loads from the deck into the plate. The ADTT-TZ may also be used in structures regulated by the IBC when an engineered design is submitted in accordance with Section 1604.8.3 of the IBC and when approved by the code official. The TDX Hold-down series include the TDX2, TDX5, TDX6, TDX8, TDX10 and TDX14 hold-downs. They are used to connect wood members to concrete foundations using cast-in-place threaded rods, in accordance with applicable standards of the IBC and IRC. The TDX hold-downs are attached to the wood member with through bolts, washer and nut.

## 3.0 DESCRIPTION

### 3.1 Hold-down and Tension Tie Devices:

**3.1.1 HTT Series Tension Tie Hold-downs:** The HTT16 and HTT45 tension tie hold-downs consist of a main structural steel strap with prepunched round holes for installation of the 10d or 16d common nails or the NA16d nails (2<sup>1</sup>/<sub>2</sub> inches long and 0.162 inches in diameter) used to connect the hold-downs to the wood member. The HTT45 includes a load transfer washer that provides a seat for an anchor rod/bolt nut. The

HTT45 tension tie hold-down is also prepunched with additional diamond shape holes for higher load capacity. The HTT series tension tie hold-downs are cold-formed from No. 10 gage galvanized steel having the minimum base metal thickness of 0.129 inch (3.28 mm). See [Table 1A](#) and [Figure 1](#) for HTT tension tie hold-down dimensions, fastener schedule requirements, and a typical installation.

**3.1.2 ADTT-TZ Adjustable Deck Tension Tie:** The ADTT-TZ Adjustable Deck Tension Tie consists of a field adjustable front brace with two vertical legs. The vertical legs are installed vertically around the joist and the front brace is installed either at an angle or horizontally flush to the joist. The angle of the front brace is dependent on the elevation difference between the bottom of the deck joist and the center of the upper top wall plate. If the deck joist bottom aligns with the upper top wall plate, the ADTT-TZ will be installed in a flush position (see [Figure 2](#)). The maximum allowable elevation difference is  $4\frac{3}{8}$  inches for dry use conditions and  $2\frac{3}{4}$  inches for wet use conditions. The ADTT-TZ also has a two-hole break-out washer that can be removed in the field from the front brace and serves as a washer for attachment to the upper top wall plate. The ADTT-TZ is manufactured from Grade 40 steel with a minimum yield strength of 40,000 psi (280 MPa) and a minimum tensile strength of 55,000 psi (380 MPa). See [Figure 2](#) and [Table 2](#) for more information.

**3.1.3 TDX Hold-down:** The TDX hold-down consists of a main steel component with a formed u-shaped base with overlapping areas welded together to form the bucket (seat). Some models also have a square washer welded on the top of the bucket. The bucket is predrilled for a cast-in-place embedded threaded rod (see [Table 3](#) for sizes). The side strap is pre-punched for through bolts for attachment to the wood member (see [Figure 3](#)). The number and diameter size of the bolt is dependent on the model number. The TDX hold-down is cold formed from either 10 gauge or 12 gauge steel with a minimum yield strength of 36,000 psi (250 MPa) and a minimum tensile strength of 58,000 psi (400 MPa). The washer is manufactured from either 7 gauge or 3 gauge steel with a minimum yield strength of 36,000 psi (250 MPa) and a minimum tensile strength of 58,000 psi (400 MPa). See [Figure 3](#) and [Table 3](#) for more information.

## 3.2 Materials:

**3.2.1 Steel:** The HTT Series tension tie hold-downs are fabricated from ASTM A653, SS, Grade 40, galvanized steel, having a minimum yield strength,  $F_y$ , of 40,000 psi (275 MPa) and a minimum tensile strength,  $F_u$ , of 55,000 psi (379 MPa). The load transfer washer supplied with the HTT45 tension ties complies with ASTM A36, having a minimum yield strength,  $F_y$ , of 36,000 psi (248 MPa) and a minimum tensile strength,  $F_u$ , of 58,000 psi (400 MPa). The galvanization of the HTT Series Tension tie hold-downs is a minimum G90 zinc coating in accordance with ASTM A653.

The ADTT-TZ is manufactured from ASTM A653 Grade 40 galvanized steel having a minimum yield strength of 40,000 psi (280 MPa) and a minimum tensile strength of 55,000 psi (380 MPa). The galvanization of the ADTT-TZ is a minimum G185 zinc coating in accordance with ASTM A653.

The TDX hold-down is manufactured from either 10 gauge or 12 gauge ASTM A653 Grade 40 steel with a minimum yield strength of 40,000 psi (280 MPa) and a minimum tensile strength of 55,000 psi (380 MPa). The washer is manufactured from either 7 gauge ASTM A1011 Grade 40 steel with a minimum yield strength of 40,000 psi (280 MPa) and a minimum tensile strength of 55,000 psi (380 MPa) or 3 gauge ASTM A36 steel with a minimum yield strength of 36,000 psi (248 MPa) and a minimum tensile strength of 58,000 psi (400 MPa).

The lumber treater or MiTek should be contacted for recommendations on minimum corrosion resistance protection of steel hold-down connectors in contact with the specific proprietary preservative-treated or fire-retardant treated lumber. The use of hold-downs in contact with preservative-treated or fire-retardant treated lumber is outside the scope of this report, and is subject to the approval of the code official.

**3.2.2 Wood:** Wood members to which the HTT Series tension tie hold-downs are attached must be sawn lumber having a minimum specific gravity of 0.50. The wood members may be multi-ply 2x sawn lumber studs or a single wood member. Multi-ply 2x sawn lumber must be fastened together to act as a single built-up column per applicable sections of the AWC *National Design Specification<sup>®</sup> for Wood Construction (NDS<sup>®</sup>)*. The minimum thickness of wood members in the direction of the fastener penetration must be 3 inches (76 mm). The minimum width of the wood members must be  $3\frac{1}{2}$  inches (89 mm) for the HTT16 tension tie hold-downs and the HTT45 when installed with 10d nails. The minimum width of the wood member must be  $5\frac{1}{2}$  inches (140 mm) for the HTT45 tension tie hold-downs when installed with NA16d nails. Wood members to which the TDX Series hold-downs and ADTT-TZ Adjustable Deck Tension Ties are attached must be sawn lumber having a minimum specific gravity of 0.50.

**3.2.3 Fasteners:** Nails used to attach the hold-downs and tension ties in this report must be bright or hot-dipped galvanized carbon steel complying with ASTM F1667 and have the minimum fastener dimensions and bending yield strengths ( $F_{yb}$ ) as noted in [Table 4](#). Alternatively, nails of other materials or finishes may be used when they are recognized in an ICC-ES evaluation report as having bending yield strength and withdrawal capacity equal to or better than those of a bright carbon steel of the same nominal diameter.

Wood screws (WS8-EXT) used for the ADTT-TZ are described in [ESR-2761](#). Lag screws ( $3/8$ " Lag-HDG) used for the ADTT-TZ must comply with ASTM A307 Grade A steel standard.

Fasteners used in contact with preservative treated or fire retardant treated lumber must be hot-dipped galvanized carbon steel nails. Alternatively, nails of other materials and finishes may be used when they are recognized in an ICC-ES evaluation report for use in the applicable treated lumber and have equivalent or greater capacities as those required in this report. The lumber treater or MiTek should be contacted for recommendations on minimum corrosion resistance and connection capacities of fasteners used with the specific proprietary preservative treated or fire retardant treated lumber.

**3.2.4 Threaded Anchor Rods:** As a minimum, threaded steel anchor bolt/rods must comply with ASTM Standards A307, A36 or F1554.

## 4.0 DESIGN AND INSTALLATION

### 4.1 Design:

**4.1.1 Hold-down or Adjustable Deck Tension Tie Assembly:** The allowable loads shown in this report are for assemblies consisting of the following components: (1) HTT Series tension tie vertical hold-downs, TDX Series vertical hold-downs or ADTT-TZ Adjustable Deck Tension Tie (2) an anchor bolt/rod attached to the seat of the HTT series or TDX series hold-downs only; (3) a wood member, having minimum specified dimensions and properties; (4) quantity and size of nails used to attach the hold-down device to the wood member; and (5) washers. The allowable loads for these assemblies are based on allowable stress design (ASD) and include the load duration factor,  $C_D$ , corresponding with the applicable loads in accordance with the AWC National Design Specification (NDS) for Wood Construction. The assembly must have an allowable strength equal to or exceeding the required strength of the assembly under the action of the ASD (Allowable Stress Design) load combinations referenced in the applicable code.

Where design load combinations include earthquake loads or effects, story drifts of the structure must be determined in accordance with Section 12.8.6 of ASCE 7 by using strength-level seismic forces without reduction for ASD. The deflection of a shear wall restrained from overturning by hold-downs installed in accordance with this report is calculated using Equation 23-2 shown in Section 2305.3 of the IBC, or Equation 4.3-1 shown in Section 4.3.4 of ANSI AWC SDPWS–2021, Section 4.3.2 of ANSI AWC SDPWS-2015 or ANSI AF&PA SDPWS-2008, as applicable. The total deflection values,  $\Delta_{all}$  and  $\Delta_s$ , at ASD-level and strength-level forces, respectively, for hold-down assemblies shown in [Tables 1B](#) of this report, include all sources of hold-down assembly elongation, such as fastener slip, hold-down device extension and rotation, and anchor rod elongation. The contribution of the hold-down anchor rod elongation to the total elongation (deflection) of the hold-down assembly needs to be considered when the actual diameter or ASTM steel specification of the anchor rod differs from that described in this report.

**Note:** For seismic design, the symbol  $\Delta_s$  as used in this report for hold-down *assemblies* refers to the symbol  $d_a$  in Section 2305.3 of the IBC and to the symbol  $\Delta_a$  in Section 4.3.4 of ANSI AWC SDPWS–2021, Section 4.3.2 of AWC SDPWS-2015 or ANSI/AF&PA SDPWS-2008, as applicable.

Tabulated allowable loads are for hold-downs connected to wood used under continuously dry interior conditions, and where sustained temperatures are 100°F (37.8°C) or less.

When hold-downs are fastened to wood having a moisture content greater than 19 percent, or where wet service is expected, the allowable loads shown in [Table 1B](#) of this report must be adjusted by the wet service factor,  $C_M$ , specified in the NDS.

When hold-downs are fastened to wood that will experience sustained exposure to temperatures exceeding 100°F (37.8°C), the allowable loads shown in [Table 1B](#) in this report must be adjusted by the temperature factor,  $C_t$ , specified in the NDS.

The design of wood members fastened to the hold-down devices must consider combined stresses due to axial tension or compression, and flexural bending induced by eccentricities in the connection about either or both axes, relative to the centroid of the wood member. Stresses must be evaluated at the critical net section for total combined stress in accordance with the NDS.

The design of hold-downs used in series must account for the cumulative deformation of all hold-downs within that series.

**4.1.2 Anchorage to Concrete or Masonry:** Adequate embedment length and anchorage details, including edge and end distances, must be determined by a registered design professional in accordance with Chapters 19 or 21 of the IBC, as applicable, for design of anchorage to concrete and masonry structural members.

Where design load combinations include earthquake loads or effects, the design strength of anchorage to concrete must be determined in accordance with Sections 1901.3 and 1905 of the 2024, 2021, 2018 and 2015 IBC or Section 1909 of the 2012 IBC, except for detached one- and two-family dwellings assigned to Seismic

Design Category A, B or C, or located where the mapped short-period spectral response acceleration,  $S_s$ , is less than 0.4g.

#### 4.2 Installation:

Installation of the HTT Series Tension Tie hold-downs, TDX Series hold-downs or ADTT-TZ Adjustable Deck Tension Tie must be in accordance with this evaluation report and the manufacturer's published installation instructions. In the event of a conflict between this report and the manufacturer's published installation instructions, this report governs.

#### 4.3 Special Inspection:

**4.3.1 IBC:** For compliance with the 2024, 2021, 2018, 2015 and 2012 IBC, a statement of special inspection must be prepared by the registered design professional in responsible charge, and submitted to the code official for approval, where required by Section 1704.3 of the 2024, 2021, 2018, 2015 and 2012 IBC. Special inspections for seismic resistance must be conducted as required, and in accordance with the appropriate sections of Chapter 17 of the IBC. Special inspections for anchor bolts in concrete or masonry must be conducted in accordance with Section 1705.3 or 1705.4 of the 2024, 2021, 2018, 2015 and 2012 IBC.

**4.3.2 IRC:** For installations under the IRC, special inspection is not required. Exception: For an engineered design where calculations are required to be signed by a registered design professional, periodic special inspection requirements and exemptions are as stated in Section 4.3.1 of this evaluation report, as applicable for installations under the IRC.

## 5.0 CONDITIONS OF USE:

The MiTek HTT Series Tension Tie hold-down connectors, TDX Series hold-downs or ADTT-TZ Adjustable Deck Tension Tie described in this report comply with, or are suitable alternatives to what is specified in, those codes listed in Section 1.0 of this report, subject to the following conditions:

- 5.1 The connectors must be manufactured, identified and installed in accordance with this report and the manufacturer's published installation instructions. A copy of the instructions must be available at the jobsite at all times during installation.
- 5.2 Calculations showing compliance with this report must be submitted to the code official. The calculations must be prepared by a registered design professional where required by the statutes of the jurisdiction in which the project is to be constructed.
- 5.3 Adjustment factors noted in Section 4.1 and the applicable codes must be considered, where applicable.
- 5.4 Connected wood members and fasteners must comply, respectively, with Sections 3.2.3 and 3.2.4 of this report.
- 5.5 Use of hold-downs with preservative- or fire-retardant-treated lumber must be in accordance with Section 3.2.1 of this report. Use of fasteners with preservative- or fire-retardant-treated lumber must be in accordance with Section 3.2.4 of this report.
- 5.6 Anchorage to concrete or masonry structural members must be designed in accordance with Section 4.1.2 of this report.
- 5.7 No further duration of load increase for wind or earthquake loading is allowed.

## 6.0 EVIDENCE SUBMITTED

Data in accordance with the [ICC-ES Acceptance Criteria for Hold-downs \(Tie-downs\) Attached to Wood Members \(AC155\)](#), dated May 2015 (editorially revised June 2024).

## 7.0 IDENTIFICATION

- 7.1 The hold-down devices described in this report are identified with a die-stamped label or an adhesive label indicating the product model (stock) number, the number of the ICC-ES index evaluation report for MiTek ([ESR-2685](#)), and by the following designation: MiTek.
- 7.2 The report holder's contact information is the following:

**MITEK<sup>®</sup> INC.**  
**16023 SWINGLEY RIDGE ROAD**  
**CHESTERFIELD, MISSOURI 63017**  
**(800) 328-5934**  
[www.mitek-us.com](http://www.mitek-us.com)  
[uspcustomerservice@mii.com](mailto:uspcustomerservice@mii.com)

TABLE 1A—DIMENSIONS AND FASTENER REQUIREMENTS FOR HTT SERIES TENSION TIE HOLD-DOWNS

STOCK NO.	STEEL GAGE	DIMENSIONS (inches)				FASTENER SCHEDULE <sup>1, 2, 3</sup>			
		W	L	D	CL	Anchor Bolts <sup>4</sup>		Nails	
						Qty	Dia.	Qty	Type
HTT16	10	2½	16	2	1¾	1	5/8	18	10dC
								18	16dC
HTT45 (Min) <sup>4</sup>	10	2½	16	2	1¾	1	5/8	18	10dC
								18	NA16d
HTT45 (Max) <sup>4</sup>	10	2½	16	2	1¾	1	5/8	26	10dC
								26	NA16d

For SI: 1 inch = 25.4 mm.

<sup>1</sup>A 10d Common nail is 3 inches long and 0.148 inches in diameter.

<sup>2</sup>A NA16d nail is 2½ inches long and 0.162 inches in diameter.

<sup>3</sup>A 16d Common nail is 3½ inches long and 0.162 inches in diameter.

<sup>4</sup>HTT45 (Min) refers to the minimum nail quantity option; HTT (Max) refers to the maximum nail quantity option.

TABLE 1B—TENSION LOADS AND DISPLACEMENTS FOR HTT SERIES HOLD-DOWN ASSEMBLIES

STOCK NO.	FASTENER SCHEDULE <sup>1,2,3,5</sup>				ALLOWABLE LOAD (lbs) <sup>4</sup>	DEFLECTION AT ALLOWABLE LOAD, Δ <sub>a</sub> (inch)	STRENGTH LEVEL FACTORED RESISTANCE, P <sub>s</sub> (lbs)	STRENGTH LEVEL DEFORMATION Δ <sub>s</sub> (inch)
	Anchor Bolts <sup>6</sup>		Nails					
	Qty	Dia.	Qty	Type	C <sub>D</sub> = 1.6			
HTT16	1	5/8	18	10dC	3,610	0.142	4,110	0.170
			18	16dC	3,735	0.162	4,940	0.232
HTT45 (Min) <sup>7</sup>	1	5/8	18	10dC	4,215	0.115	4,110	0.112
			18	NA16d	4,160	0.108	4,940	0.128
HTT45 (Max) <sup>7</sup>	1	5/8	26	10dC	5,795	0.101	5,935	0.131
			26	NA16d	5,005	0.101	7,005	0.166

For SI: 1 inch = 25.4 mm, 1 lb = 4.45 N.

<sup>1</sup>A 10d Common nail is 3 inches long and 0.148 inches in diameter.

<sup>2</sup>A NA16d nail is 2½ inches long and 0.162 inches in diameter.

<sup>3</sup>A 16d Common nail is 3½ inches long and 0.162 inches in diameter.

<sup>4</sup>Allowable loads include a 60% increase for wind or seismic load conditions. No further increase shall be permitted.

<sup>5</sup>The minimum width of the wood members for HTT16 must be 3½ inches. The minimum width of the wood members for HTT45 must be 3½ inches for 10dC nailing and 5½ inches for NA16d nailing.

<sup>6</sup>The designer must specify anchor bolt type, length and embedment depth.

<sup>7</sup>HTT45 (Min) refers to the minimum nail quantity option; HTT (Max) refers to the maximum nail quantity option.

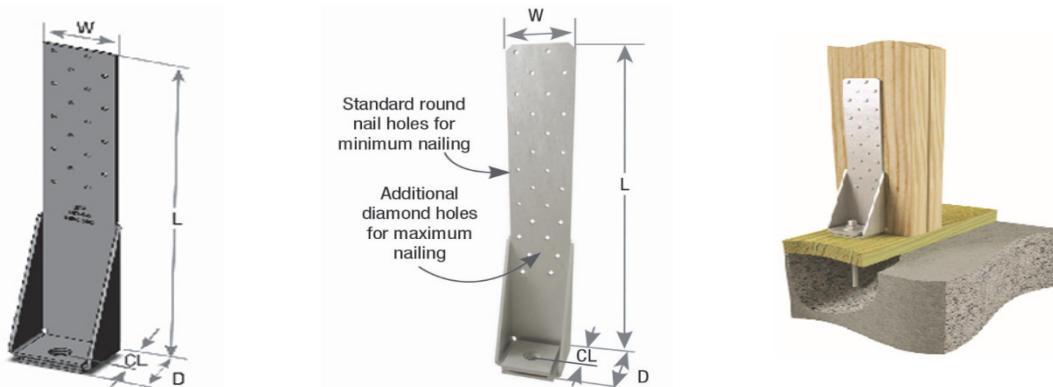

FIGURE 1—HTT16 AND HTT45 TENSION TIE HOLD-DOWN AND TYPICAL INSTALLATION



TABLE 2—ADTT-TZ TENSION TIE ASSEMBLY

STOCK NO.	STEEL GA.	DIMENSIONS (inches)				FASTENER SCHEDULE <sup>1,2,3</sup>				Installation Type <sup>5</sup>	ALLOWABLE LOAD (lbs) <sup>4</sup>						
		W	L	D	CL	Wall Fastener		Joist Nails/Screws			Dry Use $C_m = 1.0$ <sup>5</sup>			Wet Use $C_m = 0.7$ <sup>6</sup>			
						Qty	Dia.	Qty	Type		Vert. Dist from Bend Line to Joist (in)	DF-L / SP	DEFLECTION AT ALLOWABLE DESIGN LOADS (inches)	Vert. Dist from Bend Line to Joist (in)	DF-L / SP	DEFLECTION AT ALLOWABLE DESIGN LOADS (inches)	
ADTT-TZ	14	1 <sup>9</sup> / <sub>16</sub>	10 <sup>1</sup> / <sub>2</sub>	1 <sup>5</sup> / <sub>16</sub>	3 <sup>3</sup> / <sub>8</sub>	1	3 <sup>3</sup> / <sub>8</sub> " Lag - HDG		10	10d x 1-1/2	Contracted	0	820	0.070	0	820	0.070
											Extended	4- <sup>3</sup> / <sub>8</sub>	850	0.117	2- <sup>3</sup> / <sub>4</sub>	750	0.104
											Contracted	0	830	0.080	0	820	0.079
											Extended	4- <sup>3</sup> / <sub>8</sub>	835	0.113	2- <sup>3</sup> / <sub>4</sub>	750	0.108

For SI: 1 inch = 25.4 mm, 1 lbf = 4.45 N, 1 psi = 6.89 kPa

<sup>1</sup>A 10d x 1 1/2 nail is 1 1/2 inches long and 0.148 inches in diameter.

<sup>2</sup>A 3/8" Lag - HDG is an ASTM A307 Grade A lag screw with a thread diameter of 3/8 inch. The minimum thread penetration into the top plate of the wall framing is 3 inches. The lag screw is hot-dipped galvanized to ASTM A153.

<sup>3</sup>A WS8-EXT is a proprietary MiTek wood screw described in [ESR-2761](#). The minimum thread penetration into the top plate of the wall framing is 3 inches.

<sup>4</sup>Allowable loads include a 60% increase for short duration load conditions. No further increase shall be permitted.

<sup>5</sup>The listed allowable loads are for the ADTT-TZ installed tight to the bottom of the joist (contracted) and fully extended (4 inches from bottom of joist to ADTT-TZ bend line). Interpolation of allowable loads for installations with extensions between 0 inches and the maximum shown is permitted.

<sup>6</sup>Maximum extension for wet use is 2 3/4 inches to achieve the minimum 750-lb requirement as set forth in IRC R507.9.2.

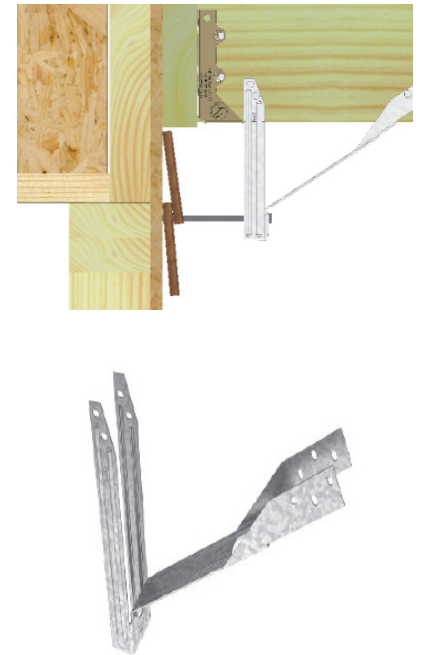
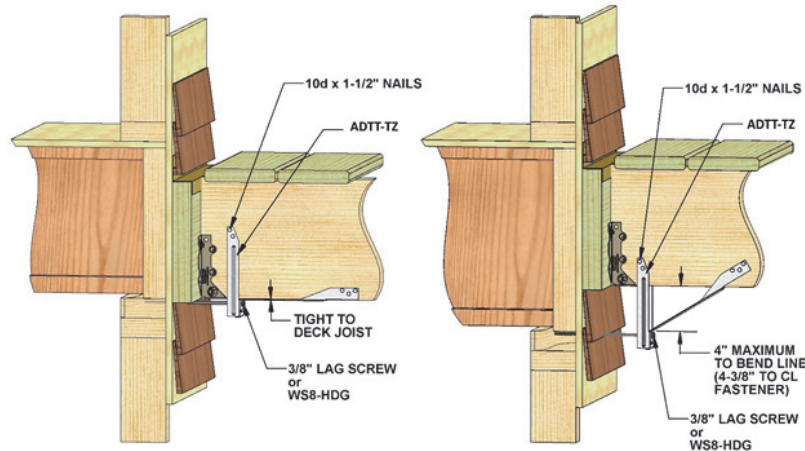
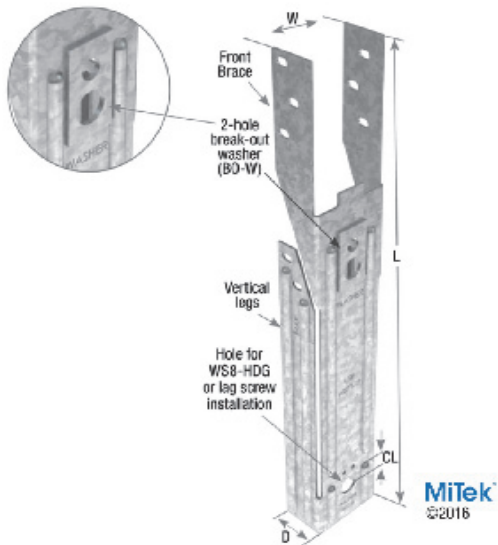

FIGURE 2—ADTT-TZ TENSION TIE AND TYPICAL INSTALLATION

TABLE 3—TDX HOLD-DOWN SERIES

STOCK NUMBER	STEEL GAGE	DIMENSIONS (inches)				FASTENER SCHEDULE					LENGTH OF BOLT IN VERTICAL MEMBER (inches) <sup>6</sup>	ALLOWABLE LOADS (lbs) <sup>2,3</sup>	DEFLECTION AT ALLOWABLE DESIGN LOADS (inches)	STRENGTH LEVEL DEFORMATION Δ <sub>s</sub> (in) <sup>4</sup>
						Anchor Bolts <sup>5</sup>		Bolts <sup>1</sup>						
		W	H	D	CL	Qty.	Size	Min. End Distance	Qty.	Size				
TDX2	12	2 <sup>1</sup> / <sub>16</sub>	8 <sup>1</sup> / <sub>8</sub>	2 <sup>3</sup> / <sub>4</sub>	1 <sup>1</sup> / <sub>2</sub>	1	5 <sup>5</sup> / <sub>8</sub>	4 <sup>1</sup> / <sub>2</sub>	2	5 <sup>5</sup> / <sub>8</sub>	1 <sup>1</sup> / <sub>2</sub>	1,920	0.150	0.142
											3	3,295	0.169	0.158
											3 <sup>1</sup> / <sub>2</sub>	3,295	0.169	0.157
											5 <sup>1</sup> / <sub>2</sub>	3,295	0.169	0.157
TDX5	10	2 <sup>1</sup> / <sub>2</sub>	9 <sup>3</sup> / <sub>8</sub>	3 <sup>7</sup> / <sub>8</sub>	2	1	3 <sup>3</sup> / <sub>4</sub>	5 <sup>1</sup> / <sub>4</sub>	2	3 <sup>3</sup> / <sub>4</sub>	1 <sup>1</sup> / <sub>2</sub>	2,340	0.079	0.074
											3	4,515	0.151	0.130
											3 <sup>1</sup> / <sub>2</sub>	4,530	0.151	0.148
											4 <sup>1</sup> / <sub>2</sub>	4,530	0.151	0.147
TDX6	7	3 <sup>1</sup> / <sub>2</sub>	11 <sup>1</sup> / <sub>8</sub>	3 <sup>3</sup> / <sub>4</sub>	2	1	7 <sup>7</sup> / <sub>8</sub>	6 <sup>1</sup> / <sub>8</sub>	2	7 <sup>7</sup> / <sub>8</sub>	1 <sup>1</sup> / <sub>2</sub>	2,835	0.093	0.089
											3	5,350	0.128	0.116
											3 <sup>1</sup> / <sub>2</sub>	5,805	0.138	0.133
											4 <sup>1</sup> / <sub>2</sub>	5,805	0.138	0.149
TDX8	7	3 <sup>1</sup> / <sub>2</sub>	14 <sup>5</sup> / <sub>8</sub>	3 <sup>3</sup> / <sub>4</sub>	2	1	7 <sup>7</sup> / <sub>8</sub>	6 <sup>1</sup> / <sub>8</sub>	3	7 <sup>7</sup> / <sub>8</sub>	1 <sup>1</sup> / <sub>2</sub>	4,160	0.060	0.056
											3	7,870	0.132	0.113
											3 <sup>1</sup> / <sub>2</sub>	9,125	0.172	0.142
											4 <sup>1</sup> / <sub>2</sub>	9,125	0.172	0.168
TDX10	7	3 <sup>1</sup> / <sub>2</sub>	18 <sup>1</sup> / <sub>8</sub>	3 <sup>3</sup> / <sub>4</sub>	2	1	7 <sup>7</sup> / <sub>8</sub>	6 <sup>1</sup> / <sub>8</sub>	4	7 <sup>7</sup> / <sub>8</sub>	3	10,140	0.128	0.110
											3 <sup>1</sup> / <sub>2</sub>	10,570	0.137	0.138
											4 <sup>1</sup> / <sub>2</sub>	10,570	0.137	0.157
											5 <sup>1</sup> / <sub>2</sub>	10,570	0.137	0.160
TDX14	3	3 <sup>1</sup> / <sub>2</sub>	20 <sup>1</sup> / <sub>2</sub>	3 <sup>5</sup> / <sub>8</sub>	2 <sup>1</sup> / <sub>8</sub>	1	1	7	4	1	3	11,995	0.117	0.106
											3 <sup>1</sup> / <sub>2</sub>	13,895	0.146	0.126
											4 <sup>1</sup> / <sub>2</sub>	15,015	0.166	0.171
											5 <sup>1</sup> / <sub>2</sub>	15,015	0.166	0.178

For SI: 1 inch = 25.4 mm, 1 lbf = 4.45 N, 1 psi = 6.89 kPa

<sup>1</sup>Bolts shall conform to ASTM A307 Grade A or better.

<sup>2</sup>Allowable loads include a 60% increase for wind or seismic load conditions. No further increase shall be permitted.

<sup>3</sup>Allowable load values of the hold-down device are a measure of the strength of the assembly with a safety factor of 3.0 applied to the lowest maximum test load.

<sup>4</sup>The design of hold-down devices used in series shall account for the cumulative deformation of all hold-downs within said series.

<sup>5</sup>The designer must specify anchor bolt type, length and embedment depth.

<sup>6</sup>The design of the framing member is outside of the scope of this report. The designer should select a framing member(s) that is sized so that the minimum end and edge distances for the fasteners, as specified in the NDS, are met and with strength properties that resist the anticipated loads.

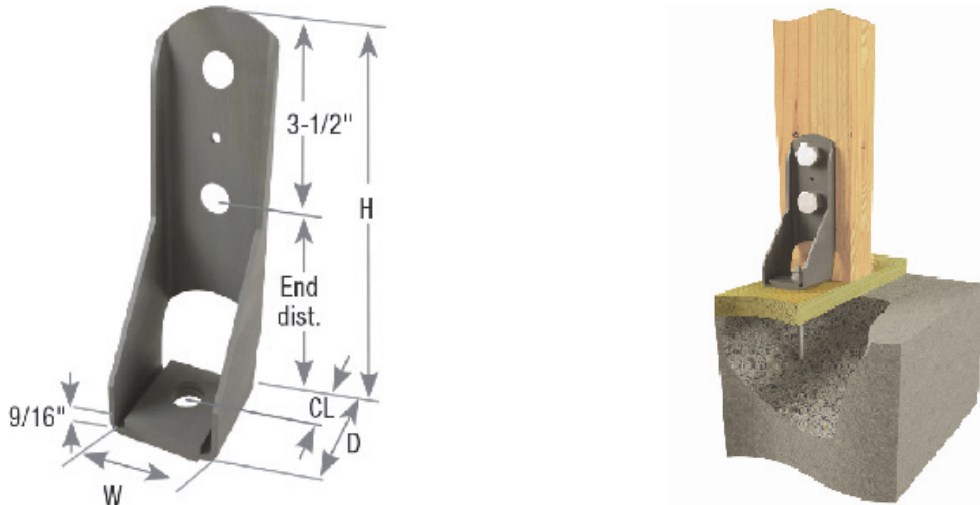

FIGURE 3—TDX HOLD-DOWN SERIES AND TYPICAL INSTALLATION

TABLE 4—MINIMUM FASTENER DIMENSIONS AND BENDING YIELD STRENGTHS

Fasteners	Shank Diameter (inch)	Nail Length (Inch)	F <sub>yb</sub> (psi)
10d x 1½	0.148	1½	90,000
10dC	0.148	3	90,000
16d x 2½ (NA16d)	0.162	2½	90,000
16dC	0.162	3½	90,000

For SI: 1 inch = 25.4 mm, 1 lbf = 4.45 N, 1 psi = 6.89 kPa



**DIVISION: 06 00 00—WOOD, PLASTICS AND COMPOSITES**  
**Section: 06 05 23—Wood, Plastic, and Composite Fastenings**

**REPORT HOLDER:**

**MITEK® INC.**

**EVALUATION SUBJECT:**

**MITEK HOLD-DOWNS AND TENSION TIES**

**1.0 REPORT PURPOSE AND SCOPE**

**Purpose:**

The purpose of this evaluation report supplement is to indicate that the MiTek HTT Series Tension Tie Hold-downs, ADTT-TZ Adjustable Deck Tension Tie, and TDX Hold-down Series, described in ICC-ES evaluation report [ESR-3847](#), have also been evaluated for compliance with the codes noted below as adopted by the Los Angeles Department of Building and Safety (LADBS).

**Applicable code editions:**

- 2023 *City of Los Angeles Building Code* (LABC)
- 2023 *City of Los Angeles Residential Code* (LARC)

**2.0 CONCLUSIONS**

The MiTek HTT Series Tension Tie Hold-downs, ADTT-TZ Adjustable Deck Tension Tie, and TDX Hold-down Series, described in Sections 2.0 through 7.0 of the evaluation report [ESR-3847](#), comply with the LABC Chapter 23, and the LARC, and are subject to the conditions of use described in this supplement.

**3.0 CONDITIONS OF USE**

The MiTek HTT Series Tension Tie Hold-downs, ADTT-TZ Adjustable Deck Tension Tie, and TDX Hold-down Series used to connect wood members to concrete foundations, described in this evaluation report supplement must comply with all of the following conditions:

- All applicable sections in the evaluation report [ESR-3847](#).
- The design, installation, conditions of use and labeling are in accordance with the 2021 *International Building Code*® (IBC) provisions noted in the evaluation report [ESR-3847](#).
- The design, installation and inspection are in accordance with additional requirements of LABC Chapters 16 and 17, Sections 2305 and 2306, as applicable.
- Under the LARC, an engineered design in accordance with LARC Section R301.1.3 must be submitted.
- In accordance with LABC Section 2305.5, allowable seismic load values of MiTek HTT Series Tension Tie Hold-downs must be 75 percent of those in the evaluation report [ESR-3847](#).
- The seismic design provisions for hillside buildings referenced in LABC Section 2301.1 have not been considered and are outside the scope of this supplement.
- The seismic design provisions in accordance with City of Los Angeles Information Bulletin P/BC 2020-071 for the design of wall anchorage assemblies to flexible diaphragms, have not been considered and are outside of the scope of this supplement.

This supplement expires concurrently with the evaluation report, reissued May 2023 revised July 2024.

**DIVISION: 06 00 00—WOOD, PLASTICS AND COMPOSITES**  
**Section: 06 05 23—Wood, Plastic, and Composite Fastenings**

**REPORT HOLDER:**

MITEK® INC.

**EVALUATION SUBJECT:**

MITEK HOLD-DOWNS AND TENSION TIES

**1.0 REPORT PURPOSE AND SCOPE****Purpose:**

The purpose of this evaluation report supplement is to indicate that MiTek HTT Series Tension Tie Hold-downs, ADTT-TZ Adjustable Deck Tension Tie, and TDX Hold-down Series, described in ICC-ES evaluation report ESR-3487, have also been evaluated for compliance with the codes noted below.

**Applicable code editions:**

- 2023 Florida Building Code—Building
- 2023 Florida Building Code—Residential

**2.0 CONCLUSIONS**

The MiTek HTT Series Tension Tie Hold-downs, ADTT-TZ Adjustable Deck Tension Tie, and TDX Hold-down Series, described in Sections 2.0 through 7.0 of ICC-ES evaluation report ESR-3487, comply with the *Florida Building Code—Building* and the *Florida Building Code—Residential*, provided the design requirements must be determined in accordance with the *Florida Building Code—Building* or the *Florida Building Code—Residential*, as applicable. The installation requirements noted in ICC-ES evaluation report ESR-3487 for the 2021 *International Building Code*® meet the requirements of the *Florida Building Code—Building* or the *Florida Building Code—Residential*, as applicable.

Use of the MiTek HTT Series Tension Tie Hold-downs, ADTT-TZ Adjustable Deck Tension Tie, and TDX Hold-down Series have also been found to be in compliance with the High-Velocity Hurricane Zone provisions of the *Florida Building Code—Building* and *Florida Building Code—Residential* with the following condition:

- a) For connections subject to uplift, the connection must be designed for no less than 700 pounds (3114 N).

For products falling under Florida Rule 61G20-3, verification that the report holder's quality assurance program is audited by a quality assurance entity approved by the Florida Building Commission for the type of inspections being conducted is the responsibility of an approved validation entity (or the code official when the report holder does not possess an approval by the Commission).

This supplement expires concurrently with the evaluation report, reissued on May 2023 and revised July 2024.