



ICC-ES Evaluation Report ESR-3745

Reissued August 2023

This report is subject to renewal August 2024.

DIVISION: 05 00 00—METALS
Section: 05 40 00—Cold-Formed Metal Framing
Section: 05 41 00—Structural Metal Stud Framing

REPORT HOLDER:

PRESCIENT COMPANY, INC.

EVALUATION SUBJECT:

PRESCIENT FIRE-RESISTANCE RATED WALL AND FLOOR-CEILING ASSEMBLIES

1.0 EVALUATION SCOPE

Compliance with the following codes:

- 2021, 2018, 2015, 2012 and 2009 *International Building Code*® (IBC)
- 2021, 2018, 2015, 2012 and 2009 *International Residential Code*® (IRC)

For evaluation for compliance with codes adopted by the Los Angeles Department of Building and Safety (LADBS), see [ESR-3745 LABC and LARC Supplement](#).

Properties evaluated:

- Structural
- Fire-resistance

2.0 USES

The Prescient fire-resistance-rated wall assemblies, with integrated trusses, and Prescient fire-resistance-rated floor-ceiling assemblies, including floor truss assemblies, may be used in fire-resistance-rated construction when installed in accordance with Sections 4.3 and 4.4 of this report. The wall panels described in this report can be used in interior, exterior, bearing and non-bearing wall applications. Penetrations through fire-resistance-rated floor-ceiling assemblies must be protected in accordance with Section 4.5 of this report. Under the IRC, the wall panels and floor-ceiling assemblies must be designed in accordance with IRC Section R301.1.3.

3.0 DESCRIPTION

3.1 General:

The Prescient fire-resistance-rated wall panels, with integrated trusses, and floor trusses are factory assembled and shipped to the jobsite for installation. Typical assembly details are provided in Figures 1, 2 and 3.

3.1.1 Wall Panels: The wall panel dimensions (lengths and heights) vary and are project specific. The wall panels consist of factory-built cold-formed steel framing members (studs and tracks for the wall panel and chord and web members for the integrated truss) and site-installed steel HSS posts described in Section 3.2.4. The HSS posts are square-shaped tubular steel spaced as indicated in the approved construction documents referenced in Section 5.2. The C-shaped chords, webs, studs and tracks are manufactured with or without web punch-outs. When provided, the punch-outs for the C-studs measure 1.5 inches by 3 inches (38 mm by 76 mm) and for the tracks measure 1.5 inches by 3.81 inches (38 mm by 97 mm), and are located along the centerline of the webs. The minimum distance between the end of the C-shape or the track and the near edge of the web punch-out is 10 inches (254 mm). The minimum distance between punch-outs is 18 inches (457 mm). Additional punch-outs holes are provided in the frame assembly to attach the perimeter members to the supporting members. The connection of the perimeter framing members to the supporting members must be designed in accordance with the IBC. See Tables 1 and 2 for recognized framing section names, profiles and dimensions. The top portion of the wall panel contains an integrated truss, as shown in Figure 2, which is designed to transmit forces between the wall panel and the floor assembly.

3.1.2 Floor Trusses: The floor truss dimensions (lengths and heights) vary and are project specific. The truss configuration is as shown in Figure 3. The floor trusses consist of cold-formed steel web and chord members as described in Tables 1 and 2 of this report. The web members consist of U-shaped sections. The chord members consist of hat-shaped sections.

3.2 Materials:

3.2.1 Studs and Tracks (Wall Panel): Studs and tracks are cold-formed from galvanized steel coils conforming to ASTM A653, SS Grade 50, Class 1. The steel has a minimum G60 galvanization coating designation in conformance with ASTM A653. Steel framing members are available in design steel thicknesses of 0.0451 inch and 0.0566 inch (1.15 and 1.44 mm), and sizes and configurations as specified in Table 1.

3.2.2 Web and Chords (Wall Panel Integrated Truss): Web and chords used in the fabrication of the integrated truss are cold-formed from galvanized steel coils conforming to ASTM A653, SS Grade 50, Class 1. The

steel has a minimum G60 galvanization coating designation in conformance with ASTM A653. Steel framing members are available in design steel thicknesses of 0.0451 inch and 0.0566 inch (1.15 and 1.44 mm), and sizes and configurations as specified in Table 1.

3.2.3 Web and Chords (Floor Trusses): Web and chord members used in the fabrication of floor trusses are cold-formed from galvanized steel coils conforming to ASTM A653, SS Grade 50, Class 1. The steel has a minimum G60 galvanization coating designation in conformance with ASTM A653. Steel framing members are available in design steel thicknesses of 0.0451 inch through 0.0713 inch (1.15 and 1.81 mm), and sizes and configurations as specified in Table 1.

3.2.4 Steel HSS Post (Wall Panel): The steel tubing post must be minimum HSS $3\frac{1}{2} \times 3\frac{1}{2} \times \frac{1}{8}$ tubing complying with ASTM A500 Grade B.

4.0 DESIGN AND INSTALLATION

4.1 Design:

The wall panel assembly with integrated trusses, and the floor-ceiling assembly, including floor trusses, must be designed in accordance with the applicable provisions of Chapters 16 and 22 of the IBC. The section properties of the cold-formed steel framing members indicated in Table 2 have been determined in accordance with the applicable edition of the North American Specification for Design of Cold-formed Steel Structural Members (AISI). The structural design, quality control, installation, testing and fabrication of truss assemblies fabricated from the cold-formed framing members described in this report must comply with AISI S202 and AISI S240 as set forth in 2021 and 2018 IBC Section 2211.1.3 and AISI S214 in the 2015 and 2012 IBC Section 2211.3 and 2009 IBC Section 2210.3.

4.2 Installation:

The wall panel assembly, integrated truss, floor-ceiling assembly and floor truss must be installed in accordance with the applicable code, the approved plans and this report. If there is a conflict between the plans submitted for approval and this report, the most restrictive requirement governs. The approved plans must be available at the jobsite at all times.

4.3 Fire-resistance-rated Wall Panel Assembly:

The Prescient wall panel assembly is a one-hour or two-hour fire-resistance-rated load bearing wall assembly when installed in accordance with the following provisions:

4.3.1 The wall assembly is prefabricated from cold formed steel framing members and steel HSS posts as described in this report. The cold-formed steel framing members consist of studs spaced a maximum of 24 inches on center, top and bottom tracks, horizontal and optional steel bracing and floor mounting brackets. The vertical sides (studs) of the cold-formed steel framing assembly, adjacent to the steel HSS posts, must be attached to the steel HSS posts with $\frac{3}{4}$ -inch diameter (19 mm) bolts in accordance with the report holder's instructions. The stud to steel HSS post connections are to be located near the top and bottom of the studs. Both sides adjacent to the posts must include the cold-formed steel framing assembly as described in this section (Section 4.3.1). Floor mounting brackets provided by PrescientCo must be spaced a maximum of 24 inches (610 mm) on center and mechanically attached to the bottom runners or tracks with four No. 12 screws. Each mounting bracket must be mechanically attached to the supporting structure in accordance with the report holder's instructions and as

shown in the approved construction documents. See Figure 1 for a typical fire-resistance rated wall panel assembly.

4.3.2 The stud cavities in the prefabricated wall assembly must be filled with minimum $3\frac{1}{2}$ -inch-thick (89 mm) unfaced fiberglass insulation having a minimum density of 0.5 pcf (8.0 kg/m³) having a flame spread index of 25 or less and a smoke developed index of 450 or less.

4.3.3 The steel HSS posts are load bearing. The axial design stress of the steel HSS posts used in the fire-resistance-rated wall assembly is the full allowable axial design load determined in accordance with Chapter E of AISC 360. The integrated truss at the top of the wall assembly is load bearing, as indicated in Section 4.4.2 of this report.

4.3.4 When installed together, the integrated truss at the top of the fire-resistance rated wall assembly is to be incorporated into the fire-resistance-rated floor-ceiling assembly described in Section 4.4. Individual protection of structural members (the steel HSS post and integrated truss), in accordance with IBC Section 704.2, 704.3, 704.4 and 704.5, is not required since protection of these individual members is provided by the fire-resistance-rated wall assembly and fire-resistance rated floor-ceiling assembly.

4.3.5 1-hour rating: One layer of $\frac{5}{8}$ -inch-thick (15.9 mm) Type SCX United States Gypsum Co. gypsum wallboard, 4 foot wide (1219 mm), applied vertically or horizontally, must be attached to the studs on both sides of the prefabricated wall assembly with 1-inch-long (25.4 mm), Type S-12 steel screws spaced 8 inches (203 mm) on center vertically in the field of the gypsum wallboard and $1\frac{1}{2}$ inches (38.1 mm) and 4 inches (101.6 mm) from the wallboard edge and ends, respectively. All exposed gypsum wallboard joints must be taped with joint tape and compound, and all screw heads must be covered with joint compound, in accordance with ASTM C840 or GA216.

4.3.6 2-hour rating: Two layers of $\frac{5}{8}$ -inch-thick (15.9 mm) Type SCX United States Gypsum Co. gypsum wallboard, 4 foot wide (1219 mm), applied vertically or horizontally, must be attached to studs on both sides of the prefabricated wall assembly. First layer must be secure with 1-inch-long (25.4 mm) Type S-12 steel screws spaced 16 inches on center (406.4 mm). Second layer must be secured with $1\frac{5}{8}$ -inch-long (41.3 mm) Type S-12 steel screws spaced 16 inches on center (406.4 mm) with screws offset 8 inches (203.2 mm) from the screws in the first layer. At the side and end joints, screws must be located $1\frac{1}{2}$ inches (38.1 mm) and 4 inches (101.6 mm) from the wallboard edge and ends, respectively. All exposed gypsum wallboard joints must be taped with joint tape and compound, and all screw heads must be covered with joint compound, in accordance with ASTM C840 or GA216.

4.4 Fire-resistance-rated Floor-ceiling Assembly:

The Prescient floor-ceiling assembly is a one-hour, $1\frac{1}{2}$ -hour or 2-hour fire-resistance-rated floor assembly when installed in accordance with the following provisions:

4.4.1 The floor-ceiling assembly must be constructed with the wall panel integrated truss consisting of the chord and web members described in Section 3.1.1. The integrated truss, included with each prefabricated wall panel section, must be connected with bolts, nuts and washers to the HSS posts as described in Section 4.3.1. The wall panel integrated truss is 18 inches deep and minimum No. 18 GSG [0.0428-inch minimum base-metal thickness (1.1 mm)] thick steel and is used to support the ends of the floor trusses described in Section 3.1.2. The HSS post,

described in the fire-resistance-rated wall assembly in Section 4.3, may be continuous and become part of this fire-resistance-rated floor-ceiling assembly as shown in Figures 1 and 2. The floor trusses are minimum 18 inches deep and spaced at maximum of 24 inches on center. The floor trusses are connected to the supporting structure in accordance with the report holder's instructions and the construction plans referenced in Section 5.2. The floor trusses are covered with a flooring system consisting of nominal 1-inch thick Plycem and/or Plycem-Fibrolit fiber cement boards, supplied by The Plycem Company, Inc., with long edges tongue and grooved. The long dimension of the boards must be perpendicular to the span of the floor trusses with end joints staggered a minimum of 24 inches (610 mm) and centered over the floor trusses. The boards are fastened to the top chords of the floor trusses with No. 8, Type S-12, self-drilling, self-countersinking, 2¹/₂-inch-long (64 mm) steel screws, or 1⁷/₈-inch (48 mm) long power pins spaced maximum 8 inches (203 mm) on center in the field and 4 inches (102 mm) on center on the perimeter with a screw located 3/4-inch (19 mm) from each edge of the board. An optional floor topping mixture, having a minimum 3/4-inch (19 mm) thickness and a minimum compressive strength of 1800 psi (12.4 MPa), may be installed over the cement boards. When used, the floor topping mixtures must be United States Gypsum Company Types LRK, HSLRK, CSD or USG Mexico SA DE CV Types LRK, HSLRD or CSD mixed in the field in accordance with the floor topping manufacturer's instructions. Resilient channels, consisting of 1/2-inch deep by 2³/₄-inch-wide (12.7 mm by 69.9 mm), minimum No. 25 GSG [0.021-inch-thick (0.53 mm)] galvanized sheet steel, must be installed perpendicular to the bottom flange of the floor trusses at 12 inches (305 mm) on center with one 7/16-inch-long (11.1 mm) No. 7 wafer head self-drilling screws. At locations where gypsum board end joints occur, additional resilient channels must be installed to provide screw attachments for the gypsum board ends. These additional channels must be positioned so that the distance from the end of the board to the center of the first channel is 3 inches (76 mm) and the board end to the center of the next channel is 12 inches (305 mm). Unfaced mineral wool or fiberglass insulation, nominal 3¹/₂-inches-thick, with minimum density of 0.5 pcf (8.0 kg/m³), having a flame spread of 25 or less and a smoke developed value of 50 or less, must be placed in the concealed space, draped over the resilient channel/gypsum board ceiling membrane.

4.4.2 Loading of the integrated truss and floor trusses of the floor-ceiling assembly is based on 100 percent LRFD design load.

4.4.3 When installed together, the integrated truss at the top of the fire-resistance rated wall assembly described in Section 4.3 is to be incorporated into the fire-resistance-rated floor-ceiling assembly. Individual protection of structural members (the steel HSS post, integrated truss and floor truss), in accordance with IBC Section 704.2, 704.3, 704.4 and 704.5, is not required since protection of these individual members is provided by the fire-resistance-rated wall assembly and fire-resistance rated floor-ceiling assembly.

4.4.4 The gypsum board membrane must comply with the following:

4.4.4.1 One-hour and 1¹/₂-hour rating: One layer of 5/8-inch-thick (15.9 mm) by 48-inch-wide (1219 mm), Type C gypsum wallboard manufactured by United States Gypsum Co., must be installed with the long dimension parallel to the floor trusses and attached to the resilient channels using 1-inch-long (25.4 mm), No. 6 bugle-head

screws, spaced a maximum of 8 inches (203 mm) on center in the field. At the butt side joints, the screws must be located 1¹/₂ (38 mm) and 4 inches (102 mm) from the gypsum wallboard edges and ends, respectively. All exposed gypsum wallboard joints must be taped with joint tape and compound, and all screw heads must be covered with joint compound, in accordance with ASTM C840 or GA216.

4.4.4.2 Two-hour rating: Two layers of 5/8-inch-thick (15.9 mm) by 48-inch-wide (1219 mm), Type C gypsum wallboard manufactured by United States Gypsum Co., must be installed with the long dimension parallel to the floor trusses. The base layer is attached to the resilient channels using 1-inch-long (25.4 mm), No. 6 bugle-head screws, spaced a maximum of 8 inches (203 mm) on center in the field. At the butt side joints, screws must be located 1¹/₂ inches (38 mm) and 4 inches (102 mm) from the gypsum wallboard edges and ends, respectively. The face layer must be attached to the resilient channels using 1⁵/₈-inch long (41 mm) Type S bugle-head screws spaced 8 inches (203 mm) on center along butted end-joints and 8 inches (203 mm) on center in the field with the screws staggered from base layer screws. The face layer side and end joints must be offset a minimum of 24 inches from base layer side and end joints. All exposed gypsum wallboard joints must be taped with joint tape and compound, and all screw heads must be covered with joint compound, in accordance with ASTM C840 or GA216.

4.5 Through-penetration Firestop Systems:

Penetrations through the one-hour fire-resistance-rated floor-ceiling systems described in Section 4.4 of this report must be protected by one of the through-penetration firestop systems described in Figures 4, 5 or 6. The systems described in the figures provide F-ratings and T-ratings of one-hour based on testing in accordance with UL 1479 (ASTM E814) as referenced by IBC Section 714.4.1.2.

5.0 CONDITIONS OF USE

The Prescient fire-resistance-rated wall and floor-ceiling assemblies described in this report comply with, or are a suitable alternative to what is specified in, those codes listed in Section 1.0 of this report, subject to the following conditions:

- 5.1** The wall panel assembly and floor-ceiling assembly described in this report must be installed in accordance with the applicable code, the approved construction documents and this report. If there is a conflict between the applicable code, the approved construction documents and this report, the most restrictive requirement governs.
- 5.2** Complete construction documents and engineering calculations verifying compliance with this report must be submitted to the code official for each project. The calculations and construction documents must be prepared and sealed by a registered design professional where required by the statutes of the jurisdiction in which the project is to be constructed.
- 5.3** When required to be of fire-resistance-rated construction, the wall panel assembly must be constructed and installed in accordance with Section 4.3 of this report. When required to be of fire-resistance-rated construction, the floor-ceiling assembly must be constructed and installed in accordance with Section 4.4 of this report.
- 5.4** The cold-formed steel framing members are manufactured in Arvada, Colorado and Mebane, North Carolina under a quality control program with inspections by ICC-ES.

6.0 EVIDENCE SUBMITTED

- 6.1 Data in accordance with the ICC-ES Acceptance Criteria for Cold-formed Steel Framing Members (AC46), dated June 2012 (editorially revised April 2015).
- 6.2 Reports of testing in accordance with UL 263 (ASTM E119) and an engineering analysis.
- 6.3 Reports of testing in accordance with UL 1479 (ASTM E814).

7.0 IDENTIFICATION

- 7.1 The cold-formed steel framing members are identified at a spacing not exceeding 96 inches (2440 mm) on center; each framing member is stamped with the

manufacturer name (PrescientCo) and the evaluation report number (ESR-3745); the minimum uncoated steel thickness in decimal inches; the minimum specified yield strength; and the galvanization coating designation for framing members with a G60 galvanization coating.

- 7.2 The report holder's contact information is the following:

PRESCIENT COMPANY, INC.
14401 WEST 65TH WAY, UNIT B
ARVADA, COLORADO 80004
(303) 214-9665
www.prescientco.com

TABLE 1—COLD-FORMED STEEL-SHAPES

MEMBER	WEB ¹ (in)	FLANGE (in)	LIP (in)	DESIGN STEEL THICKNESS (in)	MINIMUM STEEL THICKNESS ² (in)	INSIDE BEND RADIUS (in)	AREA (in ²)	WEIGHT (lb/ft)
WALL PANEL INCLUDING INTEGRATED TRUSS								
Stud/Web³								
35S-43	3.5	1.625	0.440	0.0451	0.0428	0.0712	0.328	1.12
35S-54	3.5	1.625	0.440	0.0566	0.0538	0.0849	0.407	1.39
60S-43	6.0	1.625	0.440	0.0451	0.0428	0.0712	0.441	1.50
60S-54	6.0	1.625	0.440	0.0566	0.0538	0.0849	0.549	1.87
Track/Chord³								
35T-43	3.5	1.813	-	0.0451	0.0428	0.0712	0.318	1.08
35T-54	3.5	1.813	-	0.0566	0.0538	0.0849	0.396	1.35
60T-43	6.0	1.813	-	0.0451	0.0428	0.0712	0.432	1.47
60T-54	6.0	1.813	-	0.0566	0.0538	0.0849	0.539	1.84
FLOOR TRUSS								
Chords								
H200X180-43	1.84	1.94	0.38	0.0451	0.0428	0.0712	0.273	0.93
H200x180-54	1.84	1.94	0.38	0.0566	0.0538	0.0849	0.338	1.15
H200x180-68	1.84	1.94	0.38	0.0713	0.0677	0.107	0.418	1.42
Webs								
T200x150-43	1.57	1.87	-	0.0451	0.0428	0.0712	0.218	0.74

For SI: 1 inch = 25.4 mm, 1 plf = 1.4882 kg/m

¹Web height measured from outside face to outside face of flanges for studs and from inside face to inside face for tracks.

²Minimum thickness represents 95 percent of the design thickness and is the minimum acceptable thickness of the uncoated steel delivered to the jobsite.

³Web and chord members are components of the integrated truss of the wall panel.

TABLE 2—COLD-FORMED STEEL SHAPE PROPERTIES

MEMBER	GROSS ¹					EFFECTIVE PROPERTIES ² (F _y = 50 ksi)					TORSIONAL PROPERTIES				
	I _x (in ⁴)	S _x (in ³)	R _x (in)	I _y (in ⁴)	R _y (in)	I _x ³ (in ⁴)	S _x (in ³)	A (in ²)	Ma (in-k) ⁴	Mad (in-k)	Jx1000 (in ⁴)	C _w (in ⁶)	X _o (in)	R _o (in)	β
35S-43	0.645	0.368	1.402	0.12	0.605	0.572	0.302	0.194	9.042	9.414	0.228	0.322	-1.322	2.018	0.571
35S-54	0.790	0.451	1.393	0.144	0.595	0.747	0.415	0.277	12.441	12.494	0.447	0.389	-1.313	2.005	0.571
60S-43	2.279	0.760	2.273	0.141	0.565	2.107	0.668	0.201	20.130	18.166	0.305	1.029	-1.061	2.571	0.830
60S-54	2.807	0.936	2.261	0.170	0.556	2.717	0.887	0.293	26.558	24.505	0.599	1.248	-1.051	2.556	0.831
3ST-43	0.665	0.370	1.446	0.107	0.580	0.444	0.193	0.121	5.778	-	0.218	0.238	-1.15	1.937	0.648
3ST-54	0.823	0.457	1.442	0.132	0.577	0.608	0.28	0.179	8.373	-	0.43	0.294	-1.152	1.933	0.645
60T-43	2.295	0.75	2.305	0.124	0.536	1.551	0.403	0.127	12.079	-	0.295	0.83	-0.922	2.541	0.868
60T-54	2.852	0.932	2.300	0.154	0.535	2.256	0.666	0.195	19.929	-	0.582	1.028	-0.922	2.535	0.868
H200X180-43	0.124	0.113	0.674	0.210	0.877	0.124	0.113	0.208	3.387	-	0.190	0.069	-1.621	1.963	0.318
H200X180-54	0.150	0.136	0.666	0.258	0.874	0.150	0.136	0.289	4.108	-	0.374	0.084	-1.619	1.957	0.316
H200X180-68	0.180	0.163	0.656	0.315	0.868	0.180	0.163	0.392	4.934	-	0.741	0.104	-1.620	1.952	0.311
T200X150-43	0.136	0.145	0.790	0.058	0.516	0.098	0.087	0.136	2.608	-	0.150	0.035	-1.172	1.503	0.392

For SI: 1 inch = 25.4 mm; 1 inch³ = 1.64x10⁴ mm³; 1 inch⁴ = 4.15x10⁵ mm⁴; 1 inch⁶ = 2.69x10⁸ mm⁶; 1 kip-in = 112.99 N-m; 1 ksi = 6.89 MPa; 1 lb = 4.45 N.

¹Gross properties are based on the full, unreduced cross-section, away from web punch-outs.

²Effective section properties are based on the reduced cross-section with punch-out included. For chords and webs of floor trusses effective section properties are based on the reduced cross-section.

³Use the effective moment of inertia for deflection calculation.

⁴Allowable moment is the lesser of Ma and Mad. Distortional buckling is based on an assumed kΦ=0. Ma is based on the compression flange continuously braced.

SYMBOLS

I_x = Strong axis moment of inertia
 S_x = Strong axis section modulus
 R_x = Strong axis radius of gyration
 I_y = Weak axis moment of inertia
 R_y = Weak axis radius of gyration

Ma = Strong axis allowable bending moment
 Mad = Allowable moment based on distortional buckling
 C_w = Torsional warping constant
 X_o = Distance from shear center to the centroid along the principal X-axis
 R_o = Torsional radii of gyration

β = Torsional flexural constant
 J = St. Venant torsion constant

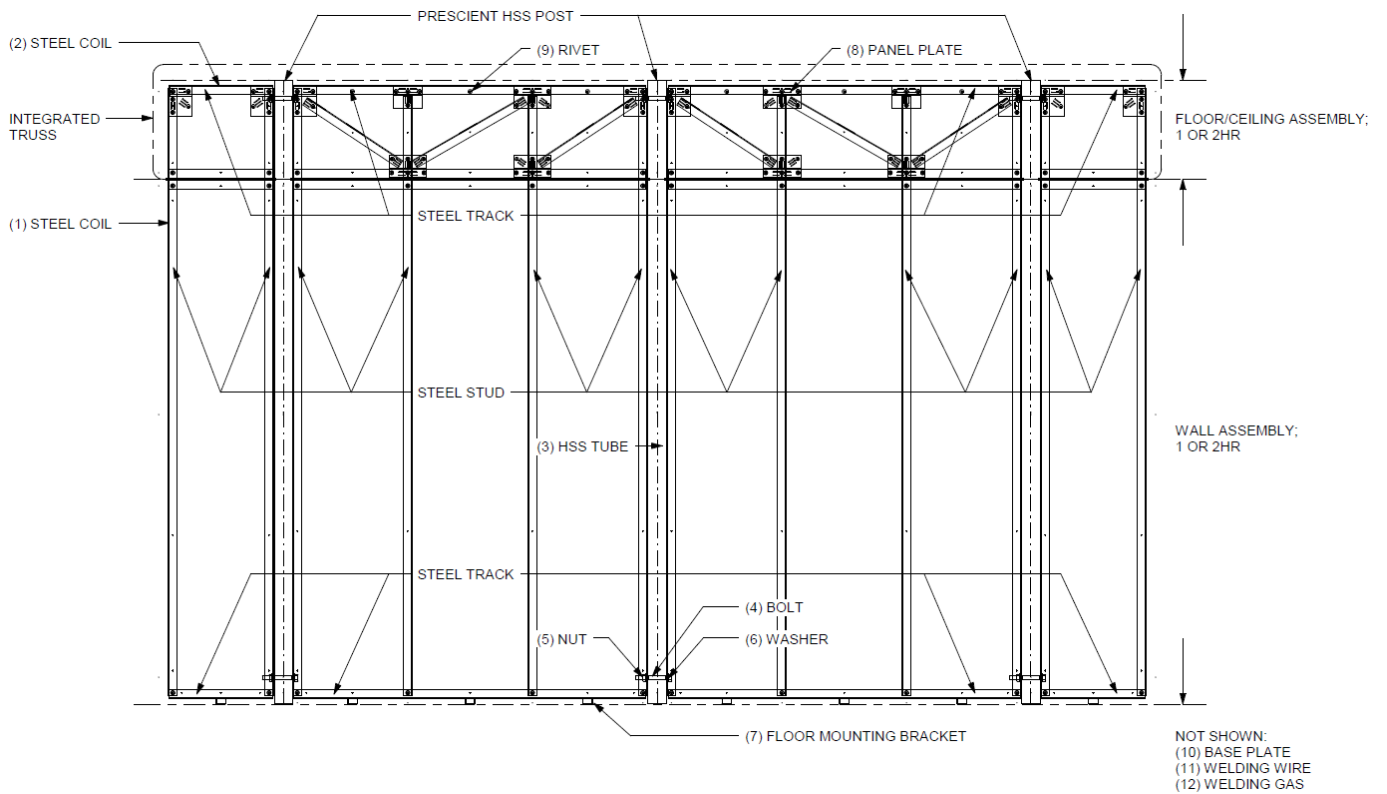

FIGURE 1—TYPICAL FIRE-RESISTANCE-RATED WALL ASSEMBLY WITH INTEGRATED TRUSS

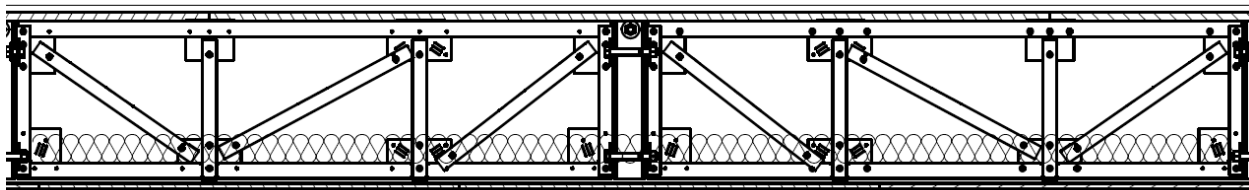

FIGURE 2—SECTION A-A (INTEGRATED TRUSS DETAIL) OF TYPICAL FLOOR-CEILING ASSEMBLY

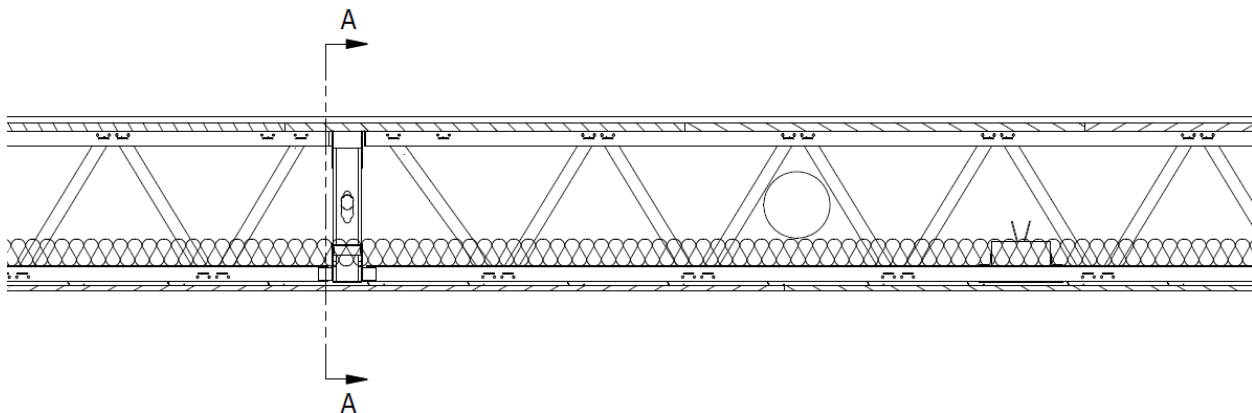
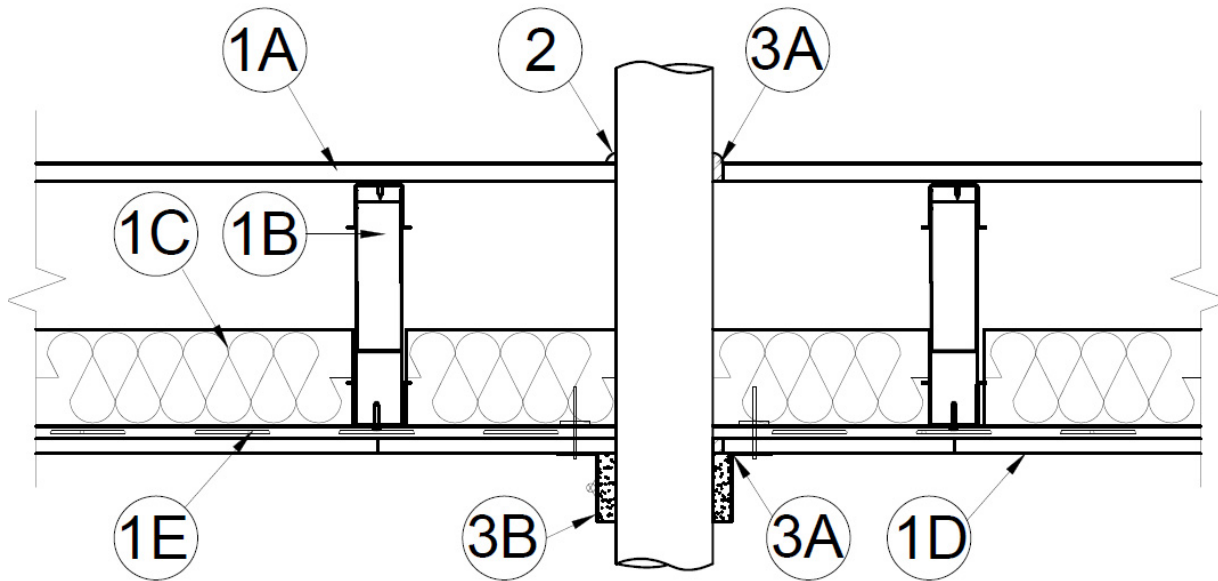

FIGURE 3—FLOOR TRUSS OF TYPICAL FLOOR-CEILING ASSEMBLY

FIGURE 4—THROUGH-PENETRATION FIRESTOP SYSTEM NO. 1:

ANSI/UL1479 (ASTM E814)
F Rating — 1 Hr
T Rating — 1 Hr



System tested with a pressure differential of 0.01 inch of water (2.49 Pa) between the exposed and the unexposed surfaces with the higher pressure on the exposed side.

1. Floor-Ceiling Assembly — The 1 hour fire-rated structural cement-fiber panel and steel truss floor-ceiling assembly shall be constructed of the materials and in the manner described in Section 4.4 of this report, as summarized below:

- A. **Flooring System** — Nominal 1 inch (25 mm) thick Type Plycem cement boards, manufactured by The Plycem Company, installed as specified in Section 4.4. Maximum diameter of cutout in flooring is 7 inches (178 mm).
- 1A. **Floor Topping Mixture** — (Optional, Not Shown) — As specified in Section 4.4, minimum 3/4 inch (19 mm) thickness of floor topping mixture having a minimum compressive strength of 1800 psi (126.6 kg/cm²). Refer to floor topping mixture manufacturer's instructions accompanying the material for specific mix design.
- UNITED STATES GYPSUM CO** — Types LRK, HSLRK, CSD
- USG MEXICO S A D E C V** — Types LRK, HSLRK, CSD
- B. **PrescientCo. Floor Trusses** — Pre-Fabricated light gauge floor truss system consisting of a cold-formed, galvanized steel cord and web sections. Floor trusses to be installed as specified in Section 4.4.
- C. **Batts and Blankets** — Nominal 3-1/2 in. (89 mm) thickness minimum density of 0.5 lb/ft³, unfaced mineral wool or glass fiber insulation bearing the UL Classification Marking for Surface Burning Characteristics, insulation fitted in the concealed space, draped over the resilient channel/gypsum board ceiling membrane as specified in Section 4.4.
- D. **Gypsum Board** — United States Gypsum Co., Type C, minimum 5/8 inch (16 mm) thick, screw-attached to furring channels as specified in Section 4.4. Maximum diameter of cutout in gypsum board ceiling is 7 inches (178 mm).

2. Through Penetrants — One nonmetallic pipe to be installed concentrically or eccentrically within the firestop system. Annular space between pipe and periphery of opening to be minimum 0 inches. (point contact) and maximum 1/2 inch (13 mm). Pipe to be rigidly supported on both sides of floor or wall assembly. The following types and sizes of nonmetallic pipes may be used:

- A. **Polyvinyl Chloride (PVC) Pipe** — Nominal 6 in. (152 mm) diameter (or smaller) Schedule 40 cellular or solid core PVC for use in closed (process or supply) or vented (drain, waste or vent) piping systems.
- B. **Chlorinated Polyvinyl Chloride (CPVC) Pipe** — Nominal 6 in. (152 mm) diameter (or smaller) SDR 13.5 CPVC for use in closed (process or supply) piping systems.
- C. **Acrylonitrile Butadiene Styrene (ABS) Pipe** — Nominal 4 inch (102 mm) diameter (or smaller) Schedule 40 cellular core ABS pipe for use in closed (process or supply) or vented (drain, waste or vent) piping systems.
- D. **Rigid Nonmetallic Conduit** — Nominal 6 inch (152 mm) diameter (or smaller) Schedule 40 PVC conduit installed in accordance with Article 347 of the National Electrical Code (NFPA 70).

3. Firestop System — The firestop system must consist of the following:

- A. **Fill, Void or Cavity Material — Sealant** — Minimum 1 inch (25 mm) thickness of fill material applied within the annulus, flush with top surface of the floor. Minimum 5/8 inch (16 mm) thickness of fill material applied within the annulus flush with bottom surface of ceiling. Additional bead of sealant applied to form a min 1/4 inch (6 mm) crown around pipe or conduit at top surface of floor and bottom surface of ceiling.
- HILTI CONSTRUCTION CHEMICALS, DIV OF HILTI INC** — FS-ONE MAX Intumescent Sealant
- B. **Firestop Device** — Galvanized steel collar lined with an intumescent material sized to fit the specific diameter of through-penetrant. Device shall be installed around the through-penetrant in accordance with the accompanying installation instructions. Device incorporates anchor tabs for securement to bottom surface of gypsum board ceiling by means of 1/8 inch (3 mm) diameter by 3 inch (76 mm) long toggle bolts and nominal 3/16 inch (5 mm) by 1-1/4 inch diameter steel fender washers. For through penetrants (Item 2) having a nominal diameter greater 4 inches, a minimum of two of the anchor tabs to be secured to the resilient channels of the gypsum board ceiling by means of No. 8 by 1-5/8 inch (41 mm) long steel screws. The other two anchor tabs to be secured to the gypsum board ceiling by means of 1/8 inch (3 mm) diameter by 3 inch (76 mm) long toggle bolts and nominal 3/16 inch (5 mm) by 1-1/4 inch diameter steel fender washers.
- HILTI CONSTRUCTION CHEMICALS, DIV OF HILTI INC** — CP643 110/4"N and CP643 152/6"N Firestop Collars.

FIGURE 5—THROUGH-PENETRATION FIRESTOP SYSTEM NO. 2:

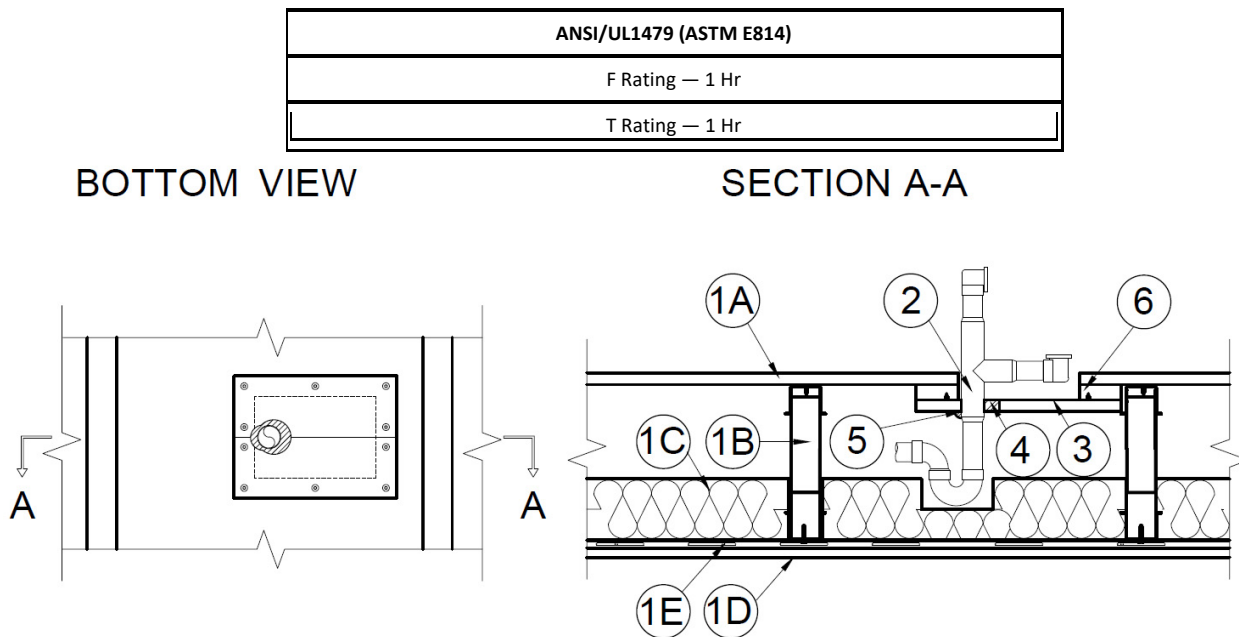

System tested with a pressure differential of 0.01 inch of water (2.49 Pa) between the exposed and the unexposed surfaces with the higher pressure on the exposed side.

1. **Floor-Ceiling Assembly** — The 1 hour fire-rated structural cement-fiber panel and steel truss floor-ceiling assembly shall be constructed of the materials and in the manner described in Section 4.4 of this report, as summarized below:

- A. **Flooring System** — Nominal 1 inch (25 mm) thick Type Plycem cement boards, manufactured by The Plycem Company, installed as specified in Section 4.4. Maximum area cutout in flooring is 96 inches² (0.062 m²). Additional two layers of nominal 1 inch (25 mm) by 3 inch (76 mm) wide strips of cement boards secured to underside of flooring by means with 1 inch (25 mm) long No. 8 self-drilling, self-countersinking steel screws spaced a max of 4 inches (102 mm) on center with a screw located 3/4 in. (19 mm) from each edge of the boards. Boards to be installed flush with the entire perimeter of the opening.
- 1A. **Floor Topping Mixture** — (Optional, Not Shown) — United States Gypsum Co. Types LRK, HSLRK or CSD or USG Mexico SA de CV Types LRK, HSLRK or CSD as specified in Section 4.4, minimum 3/4 inch (19 mm) thickness of floor topping mixture having a minimum compressive strength of 1800 psi (12.4 MPa). Refer to floor topping mixture manufacturer's instructions accompanying the material for specific mix design.
- B. **PrescientCo. Floor Trusses** — Pre-Fabricated light gauge floor truss system consisting of a cold-formed, galvanized steel cord and web sections. Floor trusses to be installed as specified in Section 4.4.
- C. **Batts and Blankets** — Nominal 3-1/2 in. (89 mm) thickness minimum density of 0.5 lb/ft³ (8.0 kg/m³), unfaced mineral wool or glass fiber insulation bearing the UL Classification Marking for Surface Burning Characteristics, insulation fitted in the concealed space, draped over the resilient channel/gypsum board ceiling membrane as specified in Section 4.4.
- D. **Gypsum Board** — United States Gypsum Co., Type C, minimum 5/8 inch (16 mm) thick, screw-attached to furring channels as specified in Section 4.4.

2. **Drain Piping** — Nominal 1-1/2 inch (38 mm) diameter (or smaller) Schedule 40 solid core polyvinyl chloride (PVC) pipe and drain fittings cemented together and provided with PVC bathtub waste/overflow fittings.

3. **Floor Patch** — Minimum 5/8 inch (16 mm) thick patch cut from United States Gypsum Co. Type C gypsum board secured to underside of floor beneath floor opening. Patch sized to lap min 2 inch (51 mm) beyond each side of floor opening. Patch split into two pieces at opening made to accommodate bathtub drain fitting (Item 2). Diameter of hole-sawed opening in patch to be 1 inch (25 mm) larger than outside diameter of bathtub drain fitting. Two pieces of patch positioned around drain fitting with cut edges tightly-butted such that the annular space between the drain fitting and the patch is minimum 0 inch (0 mm, point contact) to maximum 1 inch (25 mm). Patch secured to underside of floor with nominal 1 inch (25 mm) long Type S steel screws. Screws to be located at each corner of patch, on each side of split made to accommodate drain fitting, and maximum 6 inch (152 mm) on center around perimeter of floor opening.

4. **Fill, Void or Cavity Material — Sealant** — Minimum 5/8 inch (16 mm) thickness of fill material to be applied within annulus between the tee of the drain fitting and gypsum board patch on the top surface of the floor. An additional 1/4 inch (6 mm) crown of fill material shall be applied around tee of drain fitting on bottom surface of the gypsum board patch.

HILTI CONSTRUCTION CHEMICALS, DIV OF HILTI INC — FS-ONE MAX Intumescent Sealant

FIGURE 6—THROUGH-PENETRATION FIRESTOP SYSTEM NO. 3:

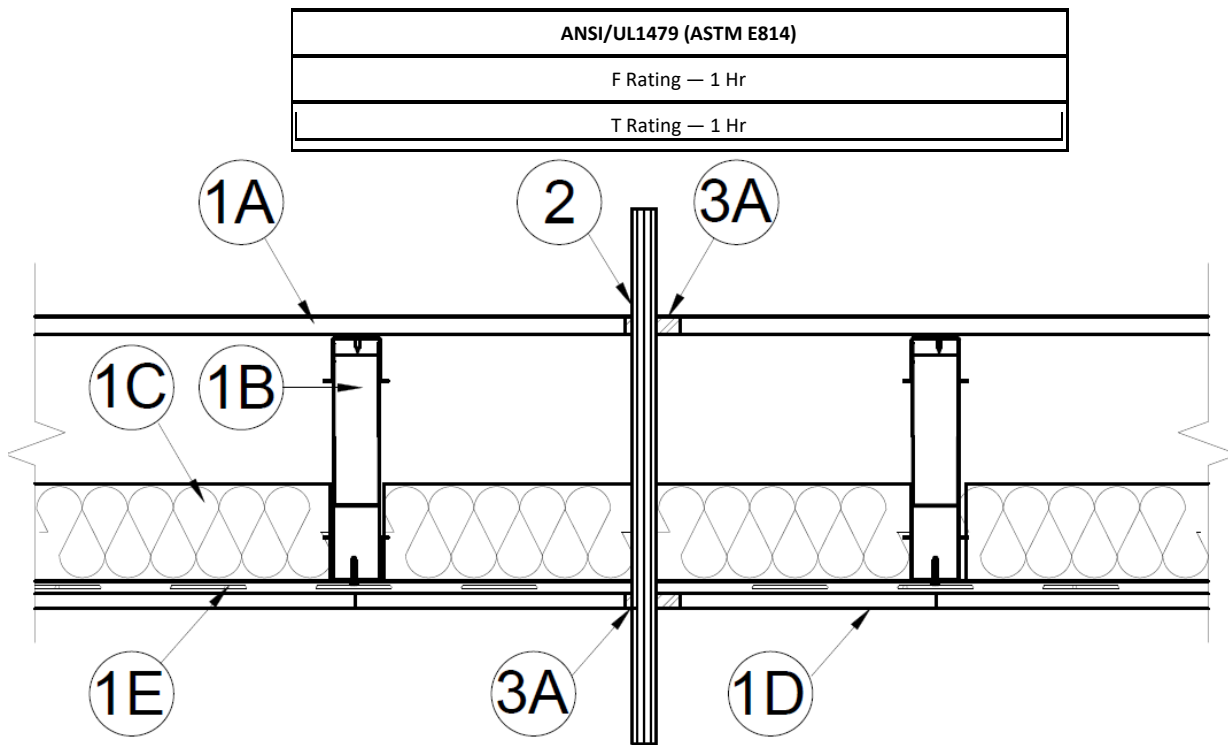

System tested with a pressure differential of 0.01 inch of water (2.49 Pa) between the exposed and the unexposed surfaces with the higher pressure on the exposed side.

1. **Floor-Ceiling Assembly** — The 1 hour fire-rated structural cement-fiber panel and steel truss floor-ceiling assembly shall be constructed of the materials and in the manner described in Section 4.4 of this report, as summarized below:

A. **Flooring System** — Nominal 1 inch (25 mm) thick Type Plycem cement boards, manufactured by The Plycem Company Inc., installed as specified in Section 4.4.. Maximum diameter of cutout in flooring is 2 inches (51 mm).

1A. **Floor Topping Mixture** — (Optional, Not Shown) — United States Gypsum Co. Types LRK, HSLRK or CSD or USG Mexico SA de CV Types LRK, HSLRK or CSD as specified in Section 4.4, minimum 3/4 inch (19 mm) thickness of floor topping mixture having a minimum compressive strength of 1800 psi (12.4 MPa). Refer to manufacturer's instructions accompanying the material for specific mix design.

B. **PrescientCo. Floor Trusses** — Pre-Fabricated light gauge floor truss system consisting of a cold-formed, galvanized steel cord and web sections. Floor trusses to be installed as specified in Section 4.4.

C. **Batts and Blankets** — Nominal 3-1/2 in. (89 mm) thickness minimum density of 0.5 lb/ft³ (8.0 kg/m³), unfaced mineral wool or glass fiber insulation bearing the UL Classification Marking for Surface Burning Characteristics, Insulation fitted in the concealed space, draped over the resilient channel/gypsum board ceiling membrane as specified in Section 4.4.

D. **Gypsum Board** — United States Gypsum Co. Type C, minimum 5/8 inch (16 mm) thick, screw-attached to furring channels as specified in Section 4.4.. Maximum diameter of cutout in gypsum board ceiling is 2 inches (51 mm).

2. **Cables** — Maximum 1 inch cable bundle to be installed concentrically or eccentrically within the opening. The annular space between the cable bundle and the periphery of the opening must be a minimum 1/8 inch (3 mm) to a maximum 7/8 inch (22 mm). Cables to be rigidly supported on both sides of floor assembly. Any combination of the following types and sizes of cables may be used:

A. Maximum 4 pair No. 24 AWG telephone cable with polyvinyl chloride (PVC) insulation and jacketing.

B. Maximum 3/C (with ground) No. 12 AWG (or smaller) copper conductor nonmetallic sheathed (Romex) cable with PVC insulation and jacket materials with PVC insulation and jacketing.

C. **Through Penetrating Products** — 3/C No. 10 AWG AFC Cable Systems Inc. Metal-Clad Cable.

3. **Firestop System** — The firestop system shall consist of the following:

A. **Fill, Void or Cavity Material — Sealant** — Minimum 1 inch (25 mm) thickness of fill material applied within the annulus, flush with top surface of the floor. Minimum 5/8 inch (16 mm) thickness of fill material applied within the annulus flush with bottom surface of ceiling. On both top and bottom surfaces of assembly, fill material forced into interstices of cable group to maximum extent possible.

HILTI CONSTRUCTION CHEMICALS, DIV OF HILTI INC — FS-ONE MAX Intumescent Sealant.

DIVISION: 05 00 00—METALS

Section: 05 40 00—Cold-Formed Metal Framing

Section: 05 41 00—Structural Metal Stud Framing

REPORT HOLDER:

PRESCIENT COMPANY, INC.

EVALUATION SUBJECT:

PRESCIENT FIRE-RESISTANCE RATED WALL AND FLOOR-CEILING ASSEMBLIES

1.0 REPORT PURPOSE AND SCOPE**Purpose:**

The purpose of this evaluation report supplement is to indicate that the Prescient fire-resistance-rated wall and floor-ceiling assemblies, described in ICC-ES evaluation report [ESR-3745](#), have also been evaluated for compliance with the codes noted below as adopted by the Los Angeles Department of Building and Safety (LADBS).

Applicable code editions:

- 2020 *City of Los Angeles Building Code* (LABC)
- 2020 *City of Los Angeles Residential Code* (LARC)

2.0 CONCLUSIONS

The Prescient fire-resistance-rated wall and floor-ceiling assemblies, described in Sections 2.0 through 7.0 of the evaluation report [ESR-3745](#), comply with the LABC Chapters 7 and 22 and the LARC, and are subjected to the conditions of use described in this supplement.

3.0 CONDITIONS OF USE

The Prescient fire-resistance-rated wall and floor-ceiling assemblies described in this evaluation report must comply with all of the following conditions:

- All applicable sections in the evaluation report [ESR-3745](#).
- The design, installation, conditions of use and identification of the Prescient fire-resistance-rated wall and floor-ceiling assemblies are in accordance with the 2018 *International Building Code*® (IBC) provisions noted in the evaluation report [ESR-3745](#).
- The design, installation and inspection are in accordance with additional requirements of LABC Chapters 7, 16, 17 and 22, as applicable.
- Under the LARC, an engineered design in accordance with LARC Section R301.1.3 must be submitted.

This supplement expires concurrently with the evaluation report, reissued August 2023.

DIVISION: 05 00 00—METALS

Section: 05 40 00—Cold-Formed Metal Framing

Section: 05 41 00—Structural Metal Stud Framing

REPORT HOLDER:

PRESCIENT COMPANY, INC.

EVALUATION SUBJECT:

PRESCIENT FIRE-RESISTANCE RATED WALL AND FLOOR-CEILING ASSEMBLIES

1.0 REPORT PURPOSE AND SCOPE**Purpose:**

The purpose of this evaluation report supplement is to indicate that the Prescient Fire-resistance-rated Wall and Floor-ceiling Assemblies, described in ICC-ES evaluation report ESR-3745, have also been evaluated for compliance with the codes noted below. Additionally, the Prescient through-penetration firestop systems, described in ICC-ES evaluation report ESR-3745, have also been evaluated for compliance with Chapter 7 of the code noted below.

Applicable code editions:

- 2019 *California Building Code* (CBC)

For evaluation of applicable chapters adopted by the California Office of Statewide Health Planning and Development (OSHPD) AKA: California Department of Health Care Access and Information (HCAI) and the Division of State Architect (DSA), see Sections 2.1.1 and 2.1.2 below.

- 2019 *California Residential Code* (CRC)

2.0 CONCLUSIONS**2.1 CBC:**

The Prescient Fire-resistance rated Wall and Floor-ceiling Assemblies, described in Sections 2.0 through 7.0 of the evaluation report ESR-3745, comply with CBC Chapters 7 and 22, provided the design and installation are in accordance with the 2018 *International Building Code*® (IBC) provisions noted in the evaluation report and the additional requirements of CBC Chapters 7, 16, 17 and 22, as applicable. The Prescient through-penetration firestop systems, described in Sections 2.0 through 7.0 of the evaluation report ESR-3745, comply with CBC Chapter 7, provided the design and installation are in accordance with the 2018 IBC provisions noted in the evaluation report and the additional requirements of CBC Chapter 7.

2.1.1 OSHPD:

The applicable OSHPD sections of the CBC are beyond the scope of this supplement.

2.1.2 DSA:

The applicable DSA sections of the CBC are beyond the scope of this supplement.

2.2 CRC:

The Prescient Fire-resistance rated Wall and Floor-ceiling Assemblies, described in Sections 2.0 through 7.0 of the evaluation report ESR-3745, comply with CRC Section R301.1.3, provided the design and installation are in accordance with the 2018 *International Building Code*® (IBC) provisions noted in the evaluation report and the additional design and inspection requirements of CBC Chapters 16 and 17, as applicable.

This supplement expires concurrently with the evaluation report, reissued August 2023.

DIVISION: 05 00 00—METALS

Section: 05 40 00—Cold-Formed Metal Framing

Section: 05 41 00—Structural Metal Stud Framing

REPORT HOLDER:

PRESCIENT COMPANY, INC.

EVALUATION SUBJECT:

PRESCIENT FIRE-RESISTANCE RATED WALL AND FLOOR-CEILING ASSEMBLIES

1.0 REPORT PURPOSE AND SCOPE**Purpose:**

The purpose of this evaluation report supplement is to indicate that the Prescient Fire-resistance rated Wall and Floor-ceiling Assemblies, including through-penetration firestop systems described in ICC-ES evaluation report ESR-3745, has also been evaluated for compliance with the code noted below.

Applicable code edition:2020 *Florida Building Code—Building***2.0 CONCLUSIONS**

The Prescient Fire-rated Bearing Wall Panel Assembly, described in Sections 2.0 through 7.0 of the evaluation report ESR-3745, complies with the 2020 *Florida Building Code—Building*, provided the design and installation are in accordance with the 2018 *International Building Code*® provisions noted in the evaluation report.

Use of the Prescient Fire-resistance rated Wall and Floor-ceiling Assemblies have also been found to be in compliance with the High-Velocity Hurricane Zone provisions of the 2020 *Florida Building Code—Building* for interior use except the minimum wall thickness of the tubular columns must be $\frac{3}{16}$ inch per Section 2219.1.

For products falling under Florida Rule 61G20-3, verification that the report holder's quality assurance program is audited by a quality assurance entity approved by the Florida Building Commission for the type of inspections being conducted is the responsibility of an approved validation entity (or the code official, when the report holder does not possess an approval by the Commission).

This supplement expires concurrently with the evaluation report, reissued August 2023.