

ICC-ES Evaluation Report

ESR-3179

Reissued October 2024

Subject to renewal October 2026

ICC-ES Evaluation Reports are not to be construed as representing aesthetics or any other attributes not specifically addressed, nor are they to be construed as an endorsement of the subject of the report or a recommendation for its use. There is no warranty by ICC Evaluation Service, LLC, express or implied, as to any finding or other matter in this report, or as to any product covered by the report.

Copyright © 2024 ICC Evaluation Service, LLC. All rights reserved.

<p>DIVISION: 06 00 00— WOOD, PLASTICS AND COMPOSITES</p> <p>Section: 06 05 23— Wood, Plastic, and Composite Fastenings</p>	<p>REPORT HOLDER: SCHRAUBENWERK GAISBACH GmbH (SWG)</p>	<p>EVALUATION SUBJECT: SWG ASSY® SCREWS</p>	
--	---	---	---

1.0 EVALUATION SCOPE

Compliance with the following codes:

- 2021, 2018, 2015, 2012, and 2009 [International Building Code® \(IBC\)](#)
- 2021, 2018, 2015, 2012, and 2009 [International Residential Code® \(IRC\)](#)

Property evaluated:

Structural

2.0 USES

SWG ASSY® screws are alternate dowel-type threaded fasteners used in engineered wood-to-wood connections that are designed in accordance with the IBC. The fasteners may be used under the IRC when an engineered design is submitted in accordance with IRC Section R301.1.3.

3.0 DESCRIPTION

3.1 General:

SWG ASSY screws have a gimlet point, and one of four head styles: hex (designated “Kombi”), washer (designated “SK”), flat head washer (FWH or SK II) or countersunk with milling pockets (designated ECO). The screws are available with nominal diameters of 1/4, 5/16, 3/8 and 1/2 inch (6, 8, 10 and 12 mm). The screws are available in boxes of loose fasteners.

3.1.1 SWG ASSY 3.0 Screws: SWG ASSY 3.0 screws are formed from carbon steel or stainless steel. The heads have a recess for an AW or RW drive, which are proprietary driving bits supplied by the report holder. The screws are partially threaded. The screws typically have a reamer knurl between the threads and the smooth shank portion of the screw, except for relatively short screws. The specified diameters and other dimensions are provided in [Table 1](#). See [Figures 1](#) through [4](#) for depictions of the carbon steel screws and [Figures 5](#) through [7](#) for depictions of the stainless steel screws.

3.1.2 SWG ASSY 3.0 LT Screws: SWG ASSY 3.0 LT screws are formed from carbon steel. The heads have a recess for an AW or RW drive. The screws have a long, partial thread and do not have a reamer knurl. The specified diameters and other dimensions are provided in [Table 2](#). See [Figure 8](#) for a depiction of the screws.

3.1.3 SWG ASSY 4 Screws: SWG ASSY 4 screws are formed from carbon steel. The heads have a recess for an RW drive. The screws are partially threaded. The screws typically have a cutting feature within the threaded portion of the screw. The specified diameters and other dimensions are provided in [Table 3](#). See [Figures 9](#) through [12](#) for depictions of the screws.

3.2 Materials:

3.2.1 SWG ASSY Screws: All SWG ASSY screws are manufactured from carbon steel. The Kombi, SK and ECO ASSY 3.0 screws are also manufactured from stainless steel.

3.2.1.1 Carbon Steel Screws: The screws are manufactured from carbon steel wire complying with the manufacturer's specifications. After the heads are formed and the threads are rolled, the screws are hardened, in accordance with the manufacturer's specifications. The hardened screws are then galvanized with a minimum zinc coating thickness of 0.0002 inch (5 μ m) and coated with a lubricant.

3.2.1.2 Stainless Steel Screws: The screws are manufactured from Grade A2 stainless steel wire complying with EN 10088-3 and EN 10263-5.

3.2.2 Wood Members: Wood members may be sawn lumber, structural glued laminated timber (glulam) or parallel strand lumber (PSL) which is a type of structural composite lumber (SCL). Screws may also be used in the face of cross-laminated timber (CLT) panels.

For purposes of connection design, sawn lumber members must have an assigned specific gravity as indicated in the tables in this report. Assigned specific gravity for sawn lumber must be determined in accordance with Table 12.3.3A of the ANSI/AWC National Design Specification for Wood Construction[®] (NDS) (Table 11.3.3A of the NDS for the 2012 IBC, Table 11.3.2A of the NDS for the 2009 IBC). Sawn lumber side and main members must have a moisture content less than or equal to 19 percent at the time of screw installation and while in service.

For the purposes of connection design, glulam must have a Specific Gravity for Fastener Design (addressed in Tables 5A through 5D of the NDS Supplement), as indicated in the tables in this report. Glulam members must have a moisture content of less than 16 percent at the time of screw installation and while in service.

When designing connections with screws installed into the face of CLT panels, all of the laminations must have a minimum assigned specific gravity in accordance with the NDS as indicated in the tables in this report. Moisture content must be less than 16 percent.

For PSL, the moisture content at the time of installation and in service must be in accordance with the applicable ICC-ES evaluation report on the PSL. PSL must have a minimum equivalent specific gravity, given in the applicable ICC-ES evaluation report, of 0.50.

Use of the screws in engineered wood products (EWP) other than those addressed above is outside the scope of this report.

The thickness of the wood main member must be equal to or greater than the screw length less the thickness of the side member. The minimum thickness of both main and side members must also be as follows: $1^{5/16}$ inch (24 mm) for $1/4$ -inch-diameter (6 mm) screws; $1^{3/16}$ inches (30 mm) for $5/16$ -inch-diameter (8 mm) screws; $1^{9/16}$ inches (40 mm) for $3/8$ -inch-diameter (10 mm) screws; and $3^{3/16}$ inches (80 mm) for $1/2$ -inch-diameter (12 mm) screws.

4.0 DESIGN AND INSTALLATION

4.1 Design:

4.1.1 General: The design values in this report are intended to aid the designer in meeting the requirements of IBC Section 1604.2. For connections not completely described in this report, determination of the suitability of the SWG ASSY screws for the specific application is the responsibility of the designer and is outside the scope of this report. The designer is responsible for determining the available strengths for the connection, considering all applicable limit states, and for considering serviceability issues.

4.1.2 Screw Strength: Allowable screw shear and tension strengths and minimum specified bending yield strength for the screws are shown in [Tables 1, 2](#) and [3](#).

4.1.3 Governing Design Values: The allowable lateral load for a single-screw connection is the lesser of: (a) the reference lateral design value described in Section 4.1.4, adjusted by all applicable adjustment factors, and (b) the allowable screw shear strength given in [Table 1, 2](#) or [3](#), as applicable. The allowable load for a single-screw connection in which the screw is subject to tension is the least of: (a) the reference withdrawal design value described in Section 4.1.5, adjusted by all applicable adjustment factors; (b) the reference head pull-through design value described in Section 4.1.5, adjusted by all applicable adjustment factors; and (c) the allowable screw tension strength given in [Table 1, 2](#) or [3](#), as applicable.

4.1.4 Reference Lateral Design Values (Z) for Wood-to-wood Connections: Reference lateral design values (Z) for single shear, wood-to-wood connections with the SWG ASSY screws loaded parallel or perpendicular to grain may be determined in accordance with Section 12.3.1 of the NDS (Section 11.3.1 of the NDS for the 2012 and 2009 IBC) using the following parameters and limitations:

1. The applicable specified bending yield strength from [Table 1](#), [2](#) of [3](#) must be used for design.
2. The minor thread diameter, D_r , must be used to determine R_d and K_D in accordance with Table 12.3.1B of the NDS, the dowel bearing strength in accordance with Table 12.3.3 of the NDS and the reference lateral design value based on Table 12.3.1A of the NDS (Tables 11.3.1B, 11.3.3 and 11.3.1 A of the 2012 NDS for the 2015 and 2012 IBC; Tables 11.3.1B, 11.3.2 and 11.3.1A of the 2005 NDS for the 2009 IBC).
3. The wood side member thickness must be a minimum of $1\frac{3}{4}$ inches (45 mm).
4. The minimum fastener penetration into the main member must be 6 times the outside thread diameter.
5. For sawn lumber and installation into the face of CLT panels, the specific gravity used for design purposes must be the assigned specific gravity in accordance with Table 12.3.3.A of the NDS (Table 11.3.3A of the NDS for the 2012 IBC, Table 11.3.2A of the NDS for the 2009 IBC).
6. For glulam, the specific gravity used for design purposes must be the applicable Specific Gravity for Fastener Design, given in Section 5 of the NDS Supplement.
7. For PSL, the specific gravity used for design purposes must be the equivalent specific gravity for the PSL given in the applicable ICC-ES evaluation report.
8. Spacing, edge and end distance must be in accordance with [Table 6](#), and as needed to prevent splitting of the wood.

4.1.5 Reference Withdrawal Design Values (W) and Head Pull-through (W_H) Design Values: Reference withdrawal design values (W) for SWG ASSY screws are given in [Table 4](#). Reference head pull-through design values (W_H) are given in [Table 5](#).

4.1.6 Adjustments to Reference Design Values: Reference design values must be adjusted in accordance with the requirements in Section 11.3 of the NDS (Section 10.3 of the NDS for the 2012 and 2009 IBC) for dowel-type fasteners. Use is limited to dry in-service conditions, such that the wet service factor, C_M , is 1.0 in accordance with the NDS. The reference design values must also be adjusted in accordance with Section 12.5 of the NDS (Section 11.5 of the NDS for the 2012 and 2009 IBC).

4.1.7 Connections with Multiple Screws: Connections made with multiple screws must be designed in accordance with Sections 11.2.2 and 12.6 of the NDS (Sections 10.2.2 and 11.6 of the NDS for the 2012 and 2009 IBC).

4.1.8 Combined Loading: Where the screws are subjected to combined lateral and withdrawal loads, connections must be designed in accordance with Section 12.4.1 of the NDS (Section 11.4.1 of the NDS for the 2012 and 2009 IBC).

4.1.9 Capacity Requirements for Wood Members: When designing a connection, the structural members must be checked for load-carrying capacity in accordance with Section 11.1.2 of the NDS (Section 10.1.2 of the NDS for the 2012 and 2009 IBC), and local stresses within multiple-fastener connections must be checked against Appendix E of the NDS to ensure the capacity of the connection and fastener group.

4.1.10 ASSY 3.0/ASSY 4 Comparison for Withdrawal and Fastener Head Pull-Through: ASSY 4 screws are a newer design of the ASSY screws than the ASSY 3.0 screws. The head pull-through capacities for the ASSY 3.0 and ASSY 4 screws are equivalent. For withdrawal the ASSY 4 screws have been shown to have capacity equal to or better than the ASSY 3.0 screws. For specified bending yield strength, the ASSY 4 screws have values equal to or better than the ASSY 3.0 screws.

4.2 Installation:

4.2.1 General: SWG ASSY screws must be installed in accordance with the manufacturer's published installation instructions and this report. Unless otherwise noted, design values in this report are applicable to screws installed such that their main axis is oriented perpendicular to the wood grain of side and main members. An appropriate screw length must be used, such that the screw will penetrate a minimum of 6 times the outside thread diameter into the main member for lateral connections; a minimum of 8 times the outside thread diameter into the main member for tension connections with carbon steel screws; and a minimum of 6 times the outside thread diameter into the main member for tension connections with stainless steel screws. The side member must be in direct contact with the main member, such that no gap exists between the wood members.

Screws must be installed using the manufacturer-recommended drive bit, with a rotary drill, or a percussion drill set to rotary only mode. Upon installation, the flat surface of the countersunk heads and the flat washer heads must be flush with the surface of the side member. The screws must not be overdriven.

4.2.2 End Distance, Edge Distance and Spacing: Minimum end distances, edge distances and spacing of the screws must be sufficient to prevent splitting of the wood, or as required by [Table 6](#), whichever is greater. When the screws are used in PSL, the minimum fastener end and edge distances and spacing must be in

accordance with [Table 6](#) or in accordance with the ICC-ES evaluation report on the PSL, whichever is more restrictive.

4.2.3 Pilot Holes: Typical installation of SWG ASSY screws does not require predrilling of the wood members; however, predrilling of holes to reduce splitting is recommended by the manufacturer for the following conditions:

1. For species which are prone to splitting, including various species of spruce and fir, including Douglas fir.
2. For lumber with thickness $\leq 1\frac{1}{2}$ inches (35 mm).
3. For laterally loaded screws installed in lumber with a thickness $\leq 7D$ ($\leq 14D$ for various species of spruce and fir, including Douglas fir).
4. For axially loaded screws installed in lumber with a thickness $\leq 10D$ and/or a width of less than $8D$ or 60 mm ($2\frac{3}{8}$ inches), whichever is greater.

For recommended sizes of predrilled holes, see [Table 7](#).

5.0 CONDITIONS OF USE:

The SWG ASSY screws described in this report comply with, or are suitable alternatives to what is specified in, those codes listed in Section 1.0 of this report, subject to the following conditions:

- 5.1 The screws must be installed in accordance with the manufacturer's published installation instructions and this report. In case of a conflict between this report and the manufacturer's installation instructions, this report governs.
- 5.2 Calculations and details demonstrating compliance with this report must be submitted to the code official. The calculations and details must be prepared by a registered design professional where required by the statutes of the jurisdiction in which the project is to be constructed.
- 5.3 The SWG ASSY screws have only been evaluated for use in dry in-service conditions where the moisture content of the wood members complies with Section 3.2.2. Use in wet service conditions is outside the scope of this report.
- 5.4 Use of fasteners in locations exposed to saltwater or saltwater spray is outside the scope of this evaluation report.
- 5.5 Use of the screws in contact with preservative-treated or fire-retardant-treated wood is outside the scope of this report.
- 5.6 SWG ASSY screws are manufactured under a quality control program with inspections by ICC-ES.

6.0 EVIDENCE SUBMITTED

Data in accordance with the [ICC-ES Acceptance Criteria for Dowel-type Threaded Fasteners Used in Wood \(AC233\)](#), dated October 2020 (editorially revised December 2020).

7.0 IDENTIFICATION

- 7.1 Individual SWG ASSY screws are identified in the field by their unique configurations. In addition, the screw heads are marked with the letters "ASSY", and may be marked with the screw length, as shown in [Figures 1](#) through [12](#). Packages of screws are identified with the manufacturer's name (SWG); product name (ASSY 3.0, ASSY 3.0 LT or ASSY 4); head type and drive size; screw diameter and length (in both inches and millimeters); and the evaluation report number (ESR-3179).
- 7.2 The report holder's contact information is the following:

SCHRAUBENWERK GAISBACH GmbH (SWG)
AM BAHNHOF 50
D-74638 WALDENBURG
GERMANY
+49 7942-9472-0
info@swg-produktion.de
www.swg-produktion.de

- 7.3 The technical support company contact information is the following:

MASS TIMBER CONNECTIONS (MTC) SOLUTIONS INC. (FORMERLY MYTICON)
(866) 899-4090
info@mtcsolutions.com
www.mtcsolutions.com

TABLE 1—FASTENER SPECIFICATIONS AND STRENGTHS – SWG ASSY 3.0 SCREWS

NOMINAL DIAMETER (inch)	HEAD STYLE	OUTSIDE THREAD DIAMETER (inch)	ROOT DIAMETER (inch)	SMOOTH SHANK DIAMETER (inch)	THREAD PITCH (inch)	HEAD DIAMETER (inch)	DRIVE TYPE AND SIZE	OVERALL LENGTH ¹ (inches)	THREAD LENGTH (inch)	TIP LENGTH (inch)	SPECIFIED BENDING YIELD STRENGTH ² , F_{yb} (psi)	ALLOWABLE FASTENER STRENGTH (ASD)		DESIGN FASTENER STRENGTH (LRFD)		
												Tension (lbf)	Shear (lbf)	Tension (lbf)	Shear (lbf)	
1/4	Washer (SK) See Figure 2	0.236	0.154	0.173	0.142	0.551	AW 30	2 ^{3/4}	1 ^{5/8}	0.236	169,500	1,150	685	1,725	1,030	
								3 ^{1/8} to 3 ^{1/2}	2							
								3 ^{7/8}	2 ^{3/8}							
	Countersunk (ECO) See Figure 3	0.236	0.154	0.173	0.142	0.472	AW 30	2 ^{3/4}	1 ^{5/8}	0.236	169,500	1,150	685	1,725	1,030	
								3 ^{1/8} to 3 ^{1/2}	2							
								3 ^{7/8}	2 ^{3/8}							
CARBON STEEL	Hex (Kombi) See Figure 1	0.315	0.209	0.228	0.220	0.467 (across flats)	AW 40 or 12 mm hex socket	3 ^{1/8} to 3 ^{1/2}	2	0.315	164,600	1,950	1,320	2,925	1,980	
								3 ^{7/8}	2 ^{3/8}							
								4 ^{3/8} to 7 ^{7/8}	3 ^{1/8}							
	Washer (SK) See Figure 2	0.315	0.209	0.228	0.220	0.866	AW 40	3 ^{1/8} to 3 ^{1/2}	2	0.315	164,600	1,950	1,320	2,925	1,980	
								3 ^{7/8}	2 ^{3/8}							
								4 ^{3/8} to 7 ^{7/8}	3 ^{1/8}							
	Countersunk (ECO) See Figure 3	0.315	0.209	0.228	0.220	0.581	AW 40	3 ^{1/8} to 3 ^{1/2}	2	0.315	164,600	1,950	1,320	2,925	1,980	
								3 ^{7/8}	2 ^{3/8}							
								4 ^{3/8} to 7 ^{7/8}	3 ^{1/8}							
	Flat Washer (FWH or SK II) See Figure 4	0.315	0.209	0.228	0.220	0.719	AW40	1 ^{3/4}	1 ^{1/4}	0.315	164,600	1,950	1,320	2,925	1,980	
								2 to 2 ^{3/16}	1 ^{9/16}							
								2 ^{3/8} to 3 ^{1/2}	2							
								3 ^{7/8}	2 ^{3/8}							
									4 ^{3/8} to 7 ^{7/8}	3 ^{1/8}	0.315	164,600	1,950	1,320	2,925	1,980
									8 ^{5/8} to 31 ^{1/2}	3 ^{7/8}						

TABLE 1—FASTENER SPECIFICATIONS AND STRENGTHS – SWG ASSY 3.0 SCREWS (Continued)

	NOMINAL DIAMETER (inch)	HEAD STYLE	OUTSIDE THREAD DIAMETER (inch)	ROOT DIAMETER (inch)	SMOOTH SHANK DIAMETER (inch)	THREAD PITCH (inch)	HEAD DIAMETER (inch)	DRIVE TYPE AND SIZE	OVERALL LENGTH ¹ (inches)	THREAD LENGTH (inch)	TIP LENGTH (inch)	SPECIFIED BENDING YIELD STRENGTH ² , F _{yb} (psi)	ALLOWABLE FASTENER STRENGTH (ASD)		DESIGN FASTENER STRENGTH (LRFD)					
													Tension (lbf)	Shear (lbf)	Tension (lbf)	Shear (lbf)				
CARBON STEEL	3/8	Hex (Kombi) See Figure 1	0.394	0.248	0.283	0.260	0.583 (across flats)	AW 40 or 15 mm hex socket	3 ⁷ / ₈	2 ³ / ₈	0.394	160,500	2,780	1,725	4,170	2,590				
									4 ³ / ₄ to 5 ¹ / ₂	3 ¹ / ₈										
									6 ¹ / ₄ to 11 ³ / ₄	3 ⁷ / ₈										
		Washer (SK) See Figure 2					0.394	0.248	0.283	0.260							0.984	AW 50	3 ⁷ / ₈	2 ³ / ₈
																			4 ³ / ₄ to 5 ¹ / ₂	3 ¹ / ₈
																			6 ¹ / ₄ to 11 ³ / ₄	3 ⁷ / ₈
		Countersunk (ECO) See Figure 3					0.394	0.248	0.283	0.260							0.713	AW 40	3 ⁷ / ₈	2 ³ / ₈
																			4 ³ / ₄ to 5 ¹ / ₂	3 ¹ / ₈
																			6 ¹ / ₄ to 11 ³ / ₄	3 ⁷ / ₈
	1/2	Hex (Kombi) See Figure 1	0.472	0.283	0.323	0.260	0.661 (across flats)	AW 40 or RW 40 or 17 mm hex socket	3 ⁷ / ₈	2 ³ / ₈	0.472	166,300	3,070	2,095	4,605	3,145				
									4 ³ / ₄ to 5 ¹ / ₂	3 ¹ / ₈										
									6 ¹ / ₄ to 7 ⁷ / ₈	3 ⁷ / ₈										
8 ⁵ / ₈ to 14 ¹ / ₈									4 ³ / ₄											
15 to 20 ¹ / ₂									5 ¹¹ / ₁₆											
Washer (SK) See Figure 2									0.472	0.283							0.323	0.260	1.142	AW 50 or RW 50
		4 ³ / ₄ to 5 ¹ / ₂	3 ¹ / ₈																	
		6 ¹ / ₄ to 7 ⁷ / ₈	3 ⁷ / ₈																	
									8 ⁵ / ₈ to 14 ¹ / ₈	4 ³ / ₄										
								15 to 20 ¹ / ₂	5 ¹¹ / ₁₆											

TABLE 1—FASTENER SPECIFICATIONS AND STRENGTHS – SWG ASSY 3.0 SCREWS (Continued)

	NOMINAL DIAMETER (inch)	HEAD STYLE	OUTSIDE THREAD DIAMETER (inch)	ROOT DIAMETER (inch)	SMOOTH SHANK DIAMETER (inch)	THREAD PITCH (inch)	HEAD DIAMETER (inch)	DRIVE TYPE AND SIZE	OVERALL LENGTH ¹ (inches)	THREAD LENGTH (inches)	TIP LENGTH (inch)	SPECIFIED BENDING YIELD STRENGTH ² , F _{yb} (psi)	ALLOWABLE FASTENER STRENGTH (ASD)		DESIGN FASTENER STRENGTH (LRFD)	
													Tension (lbf)	Shear (lbf)	Tension (lbf)	Shear (lbf)
STAINLESS STEEL	1/4	Washer (SK) See Figure 6	0.236	0.154	0.173	0.102	0.551	AW 30	1 ³ / ₈ to 1 ⁹ / ₁₆	1 ⁵ / ₁₆	0.236	99,900	600	450	900	675
									1 ³ / ₄ to 2	1 ¹ / ₄						
									2 ³ / ₁₆ to 2 ³ / ₈	1 ⁷ / ₁₆						
									2 ³ / ₄	1 ⁵ / ₈						
									3 ¹ / ₈ to 3 ¹ / ₂	2						
									3 ⁷ / ₈	2 ³ / ₈						
	Countersunk (ECO, and without milling pockets) See Figure 7	0.236	0.154	0.173	0.102	0.472	AW 30	1 ³ / ₈ to 1 ⁹ / ₁₆	1 ⁵ / ₁₆	0.315	99,500	1,170	915	1,755	1,375	
								1 ³ / ₄ to 2	1 ¹ / ₄							
								2 ³ / ₁₆ to 2 ³ / ₈	1 ⁷ / ₁₆							
								2 ³ / ₄	1 ⁵ / ₈							
								3 ¹ / ₈ to 3 ¹ / ₂	2							
								3 ⁷ / ₈	2 ³ / ₈							
	5/16	Washer (SK) See Figure 6	0.315	0.197	0.234	0.142	0.739	AW 40	2 ³ / ₈ to 3 ¹ / ₂	2	0.394	103,600	1,730	1,235	2,595	1,855
									3 ⁷ / ₈ to 4 ³ / ₈	2 ³ / ₈						
4 ³ / ₄ to 7 ⁷ / ₈									3 ¹ / ₈							
Countersunk (ECO) See Figure 7		0.315	0.197	0.234	0.142	0.581	AW 40	8 ⁵ / ₈ to 15 ³ / ₄	3 ⁷ / ₈							
								2 ³ / ₈ to 3 ¹ / ₂	2							
								3 ⁷ / ₈ to 4 ³ / ₈	2 ³ / ₈							
3/8	Hex (Kombi) See Figure 5	0.394	0.236	0.283	0.173	0.583 (across flats)	AW 40 or 15 mm hex socket	4 ³ / ₄ to 7 ⁷ / ₈	3 ¹ / ₈							
								8 ⁵ / ₈ to 15 ³ / ₄	3 ⁷ / ₈							
								2 ³ / ₈ to 3 ¹ / ₈	2							
								3 ¹ / ₂ to 4 ³ / ₈	2 ³ / ₈							

For SI: 1 inch = 25.4 mm, 1 lbf = 4.45 N, 1 psi = 6.89 kPa

¹For the Hex and Washer head styles, overall fastener length is measured from the underside of the head to bottom of tip. For the Countersunk and Flat Washer head styles, overall fastener length is measured from top of head to bottom of tip.

²Bending yield strength determined in accordance with ASTM F1575 using the root diameter.

TABLE 2—FASTENER SPECIFICATIONS AND STRENGTHS – SWG ASSY 3.0 LT SCREWS

NOMINAL DIAMETER (inch)	HEAD STYLE	OUTSIDE THREAD DIAMETER (inch)	ROOT DIAMETER (inch)	SMOOTH SHANK DIAMETER (inch)	THREAD PITCH (inch)	HEAD DIAMETER (inch)	DRIVE TYPE AND SIZE	OVERALL LENGTH ¹ (inches)	THREAD LENGTH (inch)	TIP LENGTH (inch)	SPECIFIED BENDING YIELD STRENGTH ² , F_{yb} (psi)	ALLOWABLE FASTENER STRENGTH (ASD)		DESIGN FASTENER STRENGTH (LRFD)	
												Tension (lbf)	Shear (lbf)	Tension (lbf)	Shear (lbf)
1/2	Hex (Kombi) See Figure 8	0.472	0.283	0.323	0.260	0.661 (across flats)	AW 40 or RW 40 or 17 mm hex socket	2	1 ⁹ / ₁₆	0.472	166,300	3,070	2,095	4,605	3,145
								2 ³ / ₈	2						
								2 ³ / ₄	2 ³ / ₈						
								3 ¹ / ₈	2 ³ / ₄						
								3 ¹ / ₂ to 3 ⁷ / ₈	3 ¹ / ₈						
								4 ³ / ₈ to 4 ³ / ₄	3 ⁷ / ₈						
								5 ¹ / ₈ to 5 ¹ / ₂	4 ³ / ₄						
6 ¹ / ₄ to 7 ¹ / ₈	5 ¹¹ / ₁₆														

For SI: 1 inch = 25.4 mm, 1 lbf = 4.45 N, 1 psi = 6.89 kPa

¹For the Hex and Washer head styles, overall fastener length is measured from the underside of the head to bottom of tip. For the Countersunk and Flat Washer head styles, overall fastener length is measured from top of head to bottom of tip.

²Bending yield strength determined in accordance with ASTM F1575 using the root diameter.

TABLE 3—FASTENER SPECIFICATIONS AND STRENGTHS – SWG ASSY 4 PARTIAL THREAD SCREWS

	NOMINAL DIAMETER (inch)	HEAD STYLE	OUTSIDE THREAD DIAMETER (inch)	ROOT DIAMETER (inch)	SMOOTH SHANK DIAMETER (inch)	THREAD PITCH (inch)	HEAD DIAMETER (inch)	DRIVE TYPE AND SIZE	OVERALL LENGTH ¹ (inches)	THREAD LENGTH (inch)	TIP LENGTH (inch)	SPECIFIED BENDING YIELD STRENGTH ² , F_{yb} (psi)	ALLOWABLE FASTENER STRENGTH (ASD)		DESIGN FASTENER STRENGTH (LRFD)	
													Tension (lbf)	Shear (lbf)	Tension (lbf)	Shear (lbf)
CARBON STEEL	1/4	Washer (SK) See Figure 10	0.236	0.154	0.175	0.142	0.551	RW 40	2 ³ / ₄	1 ⁵ / ₈	0.236	181,200	1,075	700	1,610	1,050
									3 ¹ / ₈ to 3 ¹ / ₂	2						
									3 ⁷ / ₈	2 ³ / ₈						
									4 ³ / ₈ to 11 ³ / ₄	2 ³ / ₄						
		Countersunk (ECO) See Figure 11	0.236	0.154	0.173	0.142	0.472	RW 40	RW 40	2 ³ / ₄	1 ⁵ / ₈					
										3 ¹ / ₈ to 3 ¹ / ₂	2					
										3 ⁷ / ₈	2 ³ / ₈					
										4 ³ / ₈ to 11 ³ / ₄	2 ³ / ₄					

TABLE 3—FASTENER SPECIFICATIONS AND STRENGTHS – SWG ASSY 4 PARTIAL THREAD SCREWS (Continued)

NOMINAL DIAMETER (inch)	HEAD STYLE	OUTSIDE THREAD DIAMETER (inch)	ROOT DIAMETER (inch)	SMOOTH SHANK DIAMETER (inch)	THREAD PITCH (inch)	HEAD DIAMETER (inch)	DRIVE TYPE AND SIZE	OVERALL LENGTH ¹ (inches)	THREAD LENGTH (inch)	TIP LENGTH (inch)	SPECIFIED BENDING YIELD STRENGTH ² , F_{yb} (psi)	ALLOWABLE FASTENER STRENGTH (ASD)		DESIGN FASTENER STRENGTH (LRFD)									
												Tension (lbf)	Shear (lbf)	Tension (lbf)	Shear (lbf)								
CARBON STEEL	5/16	Hex (Kombi) See Figure 9	0.315	0.209	0.228	0.220	0.467 (across flats)	RW 40 or 12 mm hex socket	3 1/8 to 3 1/2	2	0.315	164,600	1,790	1,220	2,685	1,830							
									3 7/8	2 3/8													
									4 3/8 to 7 7/8	3 1/8													
									8 5/8 to 31 1/2	3 7/8													
		Washer (SK) See Figure 10	0.315	0.209	0.228	0.220	0.220	0.866	RW 40	3 1/8 to 3 1/2							2						
										3 7/8							2 3/8						
										4 3/8 to 7 7/8							3 1/8						
										8 5/8 to 31 1/2							3 7/8						
		Countersunk (ECO) See Figure 11	0.315	0.209	0.228	0.220	0.220	0.583	RW 40	3 1/8 to 3 1/2							2						
										3 7/8							2 3/8						
										4 3/8 to 7 7/8							3 1/8						
										8 5/8 to 31 1/2							3 7/8						
	Flat Washer (FWH or SK II) See Figure 12	0.315	0.209	0.228	0.220	0.220	0.719	RW40	1 3/4	1 1/4													
									2 to 2 3/16	1 9/16													
									2 3/8 to 3 1/2	2													
									3 7/8	2 3/8													
								4 3/8 to 7 7/8	3 1/8														
								8 5/8 to 31 1/2	3 7/8														
								3/8	Hex (Kombi) See Figure 9	0.394	0.256	0.283	0.260	0.581 (across flats)	RW 40 or 15 mm hex socket	3 7/8	2 3/8	0.394	170,200	2,690	1,930	4,040	2,890
																4 3/4 to 5 1/2	3 1/8						
6 1/4 to 11 3/4	3 7/8																						
12 5/8 to 39 3/8	4 3/4																						
Washer (SK) See Figure 10	0.394	0.256	0.283	0.260	0.260	0.984	RW 50		3 7/8	2 3/8													
									4 3/4 to 5 1/2	3 1/8													
								6 1/4 to 11 3/4	3 7/8														
								12 5/8 to 39 3/8	4 3/4														
Countersunk (ECO) See Figure 11	0.394	0.256	0.283	0.260	0.260	0.713	RW 40	3 7/8	2 3/8														
								4 3/4 to 5 1/2	3 1/8														
								6 1/4 to 11 3/4	3 7/8														
								12 5/8 to 39 3/8	4 3/4														

For SI: 1 inch = 25.4 mm, 1 lbf = 4.45 N, 1 psi = 6.89 kPa

¹For the Hex and Washer head styles, overall fastener length is measured from the underside of the head to bottom of tip. For the Countersunk and Flat Washer head styles, overall fastener length is measured from top of head to bottom of tip.

²Bending yield strength determined in accordance with ASTM F1575 using the root diameter

TABLE 4—REFERENCE WITHDRAWAL DESIGN VALUES (W) FOR ASSY 3.0, ASSY 3.0 LT AND ASSY 4 SCREWS^{1,2,3,4} lbf/in

NOMINAL FASTENER DIAMETER (inch)	MINIMUM EMBEDDED THREAD LENGTH ⁵ , (inches)	FOR SPECIFIC GRAVITIES (SG) AND EQUIVALENT SPECIFIC GRAVITIES (ESG) OF: ⁶				
		SG = 0.55	SG = 0.49	SG = 0.42	SG = 0.35	ESG ≥ 0.50
Carbon Steel Screws						
1/4	2	230	202	169	137	156
5/16	2 1/2	279	248	212	176	179
3/8	3	317	280	237	190	211
1/2	4	334	297	254	211	223
Stainless Steel Screws						
1/4	2	n/a	162	143	n/a	n/a
5/16	2 1/2	n/a	211	169	n/a	n/a
3/8	3	n/a	211	180	n/a	n/a

For SI: 1 inch = 25.4 mm, 1 lbf = 4.45 N.

¹Tabulated reference withdrawal design values, W, apply to screws installed perpendicular to the faces of the wood members.

²Values must be multiplied by all adjustment factors included in the NDS for dowel-type fasteners to determine allowable loads for use with ASD and/or design loads for use with LRFD.

³SWG ASSY screws must be installed and used in dry in-service conditions, such that the wet service factor, C_M, is 1.0 in accordance with the NDS.

⁴Reference withdrawal design values are to be multiplied by the length of thread penetration into the main member.

⁵Embedded thread length is that portion of the screw held in the main member excluding the screw tip.

⁶The specific gravity used for design purposes must be the assigned specific gravity for sawn lumber per NDS Table 12.3.3A (Table 11.3.3A of NDS for the 2012 IBC, Table 11.3.2A of NDS for the 2009 IBC), and the equivalent specific gravity (ESG) must be the equivalent specific gravity given in the applicable ICC-ES evaluation report on the PSL product.

TABLE 5—REFERENCE HEAD PULL-THROUGH DESIGN VALUES (W_H) FOR ASSY 3.0, ASSY 3.0 LT AND ASSY 4 SCREWS^{1,2,3} lbf

NOMINAL FASTENER DIAMETER (inches)	HEAD TYPE	MINIMUM SIDE MEMBER THICKNESS (inches)	FOR SPECIFIC GRAVITIES (SG) AND EQUIVALENT SPECIFIC GRAVITIES (ESG) OF: ⁴				
			SG = 0.55	SG = 0.49	SG = 0.42	SG = 0.35	ESG ≥ 0.50
Carbon Steel Screws							
1/4	Washer	1 3/8	407	356	299	244	440
	Countersunk		221	194	163	133	262
5/16	Hex		275	233	188	146	326
	Washer		685	604	510	410	732
	Countersunk		318	277	232	187	327
3/8	Flat Washer		n/a	480	406	n/a	n/a
	Hex		369	327	278	225	420
	Washer		710	660	593	513	797
1/2	Countersunk		445	385	319	246	509
	Hex		390	351	305	257	474
	Washer	834	738	627	517	939	
Stainless Steel Screws							
1/4	Washer	1 3/8	407	356	299	244	440
	Countersunk		221	194	163	133	262
5/16	Washer		685	604	510	410	732
	Countersunk		n/a	524	445	n/a	n/a
3/8	Hex		369	327	278	225	420

For SI: 1 inch = 25.4 mm, 1 lbf = 4.45 N.

¹Tabulated head pull-through design values, W_H, are applicable to screws installed perpendicular to the faces of the wood members and must be multiplied by all adjustment factors included in the NDS for dowel-type fasteners to determine allowable loads for use with ASD and/or design loads for use with LRFD.

²Design values apply to connections with minimum side member thicknesses given above.

³SWG ASSY screws must be installed and used in dry in-service conditions, such that the wet service factor, C_M, is 1.0 in accordance with the NDS.

⁴The specific gravity (SG) used for design purposes must be the assigned specific gravity for sawn lumber per NDS Table 12.3.3A (Table 11.3.3A of NDS for the 2012 IBC, Table 11.3.2A of NDS for the 2009 IBC), and the equivalent specific gravity (ESG) must be the equivalent specific gravity given in the applicable ICC-ES evaluation report on PSL product.

TABLE 6—CONNECTION GEOMETRY REQUIREMENTS FOR ASSY SCREWS INSTALLED PERPENDICULAR TO THE FACE OF WOOD MEMBERS^{1,2,3}

CONDITION		MINIMUM DISTANCE OR SPACING		
		G ⁵ < 0.50	0.50 ≤ G ⁵	
For ASSY 3.0 and ASSY 4 screws with nominal diameters of 1/4 inch and 5/16 inch				
End distance	Tension loading parallel to grain (fastener bearing toward end)		15D	20D
	Compression loading parallel to grain (fastener bearing away from end)		10D	15D
	Loading perpendicular to grain		10D	15D
	Axial loading (fastener withdrawal or pull-through)		10D	10D
Edge distance	Loading parallel to grain		5D	7D
	Loading perpendicular to grain	Load toward edge	10D	12D
		Load away from edge	5D	7D
	Axial Loading		4D	4D
Spacing between fasteners in a row (parallel to grain of main member)	Loading parallel to grain		15D	15D
	Loading perpendicular to grain		10D	10D
	Axial loading		7D	7D
Spacing between rows (perpendicular to grain of main member)	Lateral loading	In-line rows	5D	7D
		Staggered rows ⁴	2.5D	3D
	Axial loading		4D	4D
For ASSY 3.0 and ASSY 4 screws with nominal diameters of 3/8 inch and 1/2 inch				
End distance	Tension loading parallel to grain (fastener bearing toward end)		15D	20D
	Compression loading parallel to grain (fastener bearing away from end)		10D	15D
	Loading perpendicular to grain		10D	15D
	Axial loading		10D	10D
Edge distance	Loading parallel to grain		5D	7D
	Loading perpendicular to grain	Load toward edge	10D	12D
		Load away from edge	5D	7D
	Axial Loading		4D	4D
Spacing between fasteners in a row (parallel to grain of main member)	Loading parallel to grain		15D	15D
	Loading perpendicular to grain		10D	10D
	Axial loading		7D	7D
Spacing between rows (perpendicular to grain of main member)	Loading parallel to grain		5D	7D
	Loading perpendicular to grain		5D	5D
	Axial loading		5D	5D

For SI: 1 inch = 25.4 mm.

¹End distances, edge distances and fastener spacing must be sufficient to prevent splitting of the wood, or as required by this table, whichever is the more restrictive.

²Wood member stresses must be checked in accordance with Section 11.1.2 and Appendix E of the NDS, and end distances, edge distances and fastener spacing may need to be increased accordingly.

³D refers to the outside thread diameter.

⁴Values for spacing between staggered rows apply where fasteners in adjacent rows are offset by half of the spacing between fasteners in a row.

⁵Unless noted otherwise for specific species.

TABLE 7—RECOMMENDED DIAMETER OF PREDRILLED HOLES¹ inches

NOMINAL FASTENER DIAMETER (mm) [inches]	APPLICABLE LOAD CONDITION AND SPECIFIC GRAVITY		
	Screws Subject to Lateral Load		Screws Loaded Axially
	SG ≤ 0.5	SG > 0.5 and PSL	0.35 ≤ SG ≤ 0.55 and PSL
1/4	5/32	5/32	5/32
5/16	13/64	7/32	13/64
3/8	15/64	1/4	15/64
1/2	17/64	5/16	17/64

For SI: 1 inch = 25.4 mm.

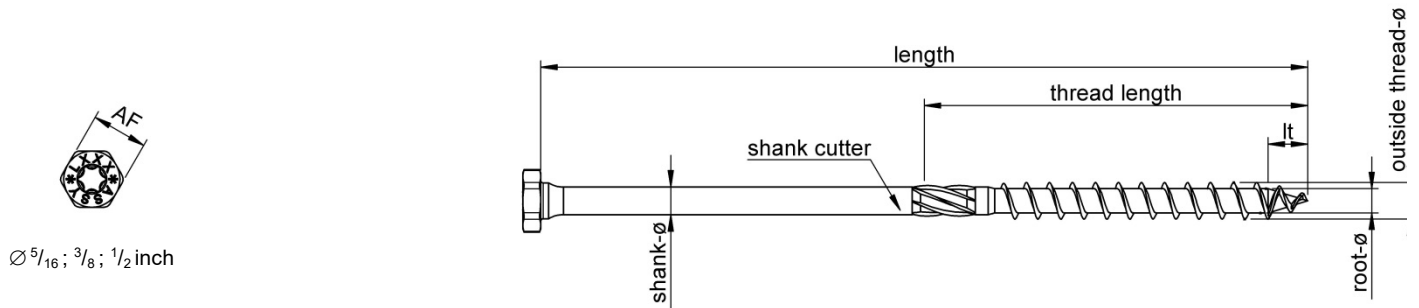

FIGURE 1—ASSY 3.0 CARBON STEEL SCREW WITH HEX HEAD (KOMBI)

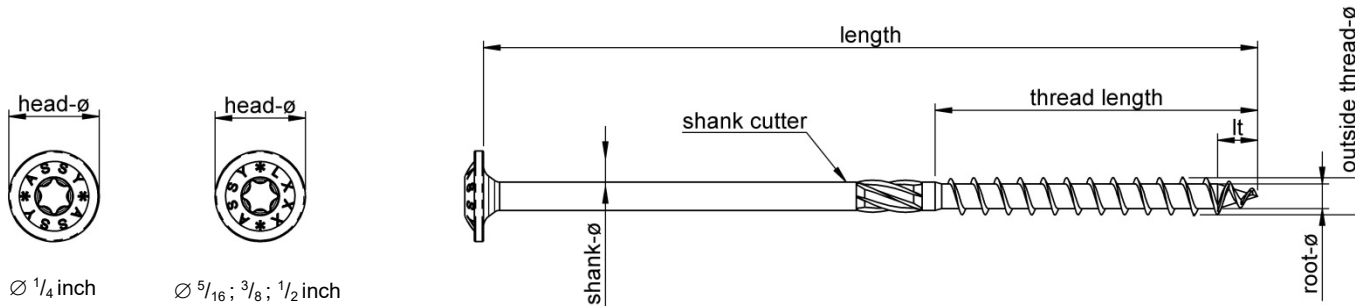

FIGURE 2—ASSY 3.0 CARBON STEEL SCREW WITH WASHER HEAD (SK)

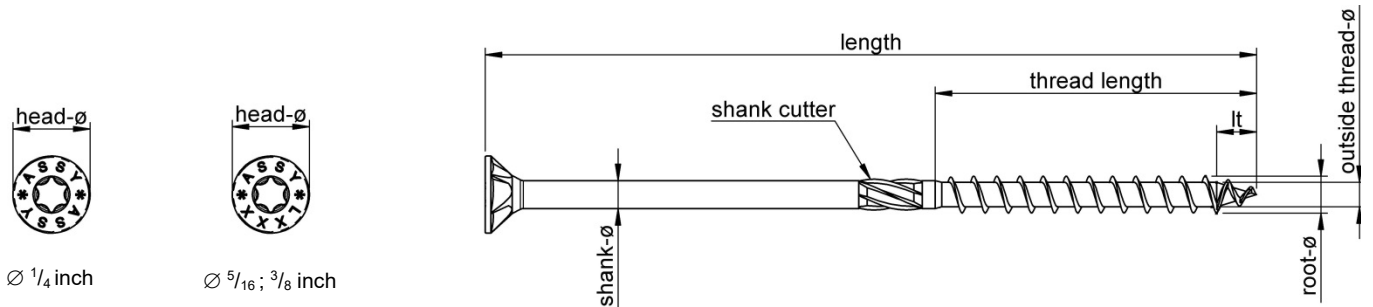

FIGURE 3—ASSY 3.0 CARBON STEEL SCREW WITH COUNTERSUNK HEAD WITH MILLING POCKETS (ECO)

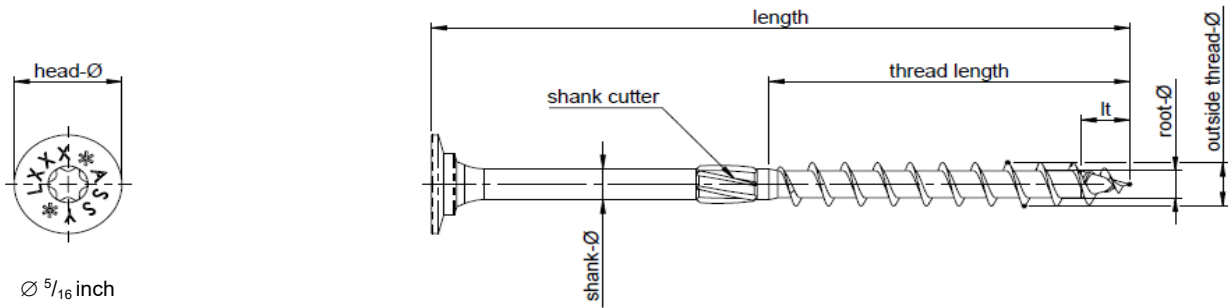

FIGURE 4—ASSY 3.0 CARBON STEEL SCREW WITH FLAT WASHER HEAD (FWH OR SK II)

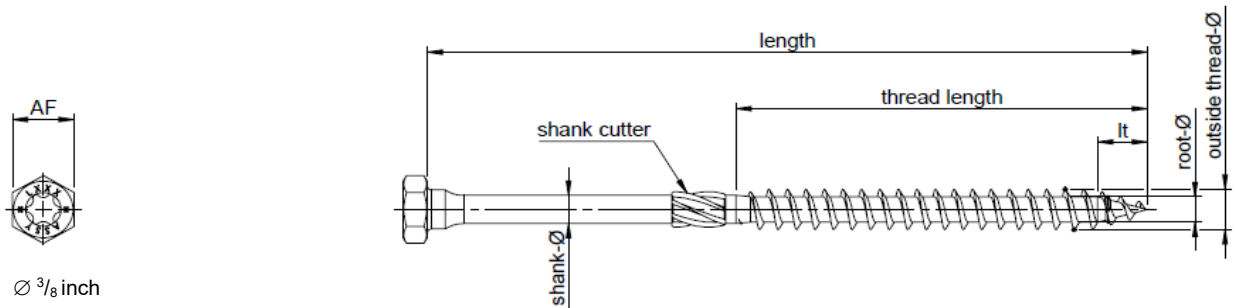

FIGURE 5—ASSY 3.0 STAINLESS STEEL SCREW WITH HEX HEAD (KOMBI)

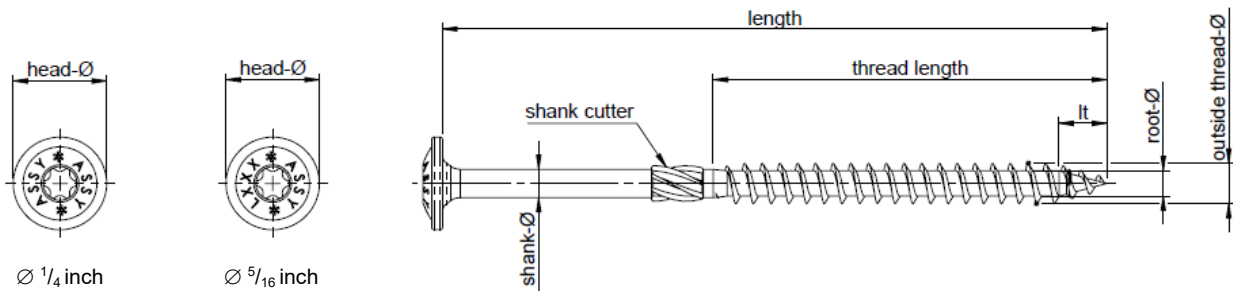

FIGURE 6—ASSY 3.0 STAINLESS STEEL SCREW WITH WASHER HEAD (SK)

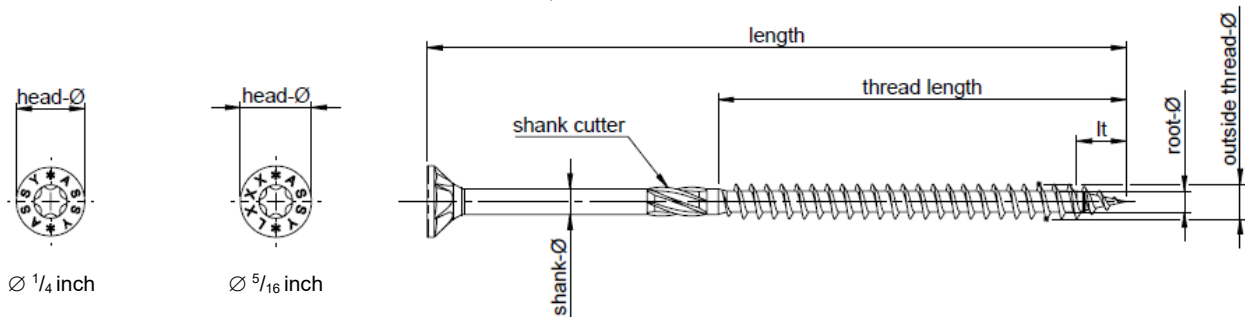

FIGURE 7—ASSY 3.0 STAINLESS STEEL SCREW WITH COUNTERSUNK HEAD WITH MILLING POCKETS (ECO)

Note: ASSY 3.0 screw with countersunk head without milling pockets is similar.

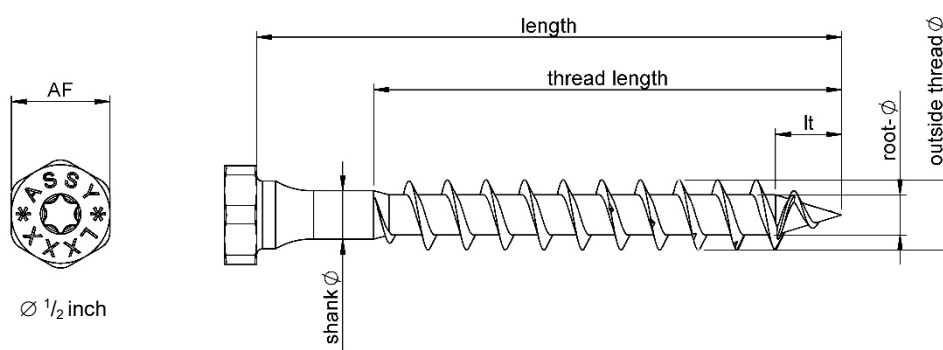

FIGURE 8—ASSY 3.0 LT SCREW WITH HEX HEAD (KOMBI)

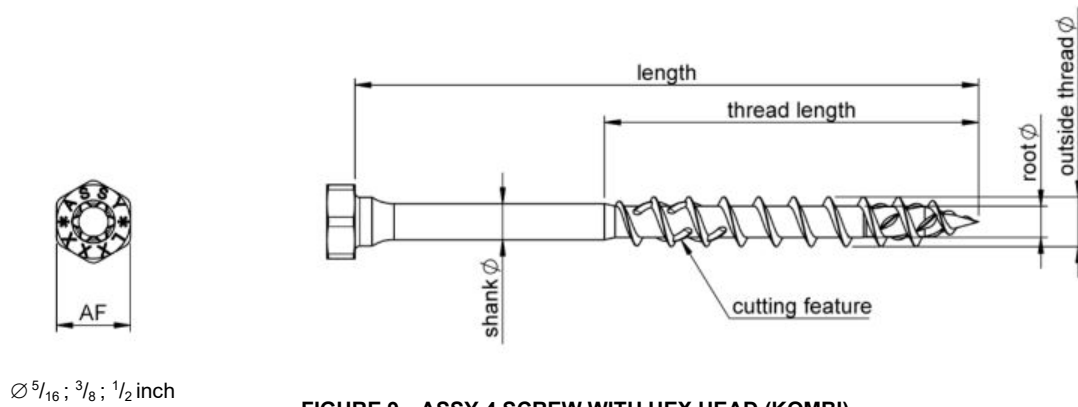

FIGURE 9—ASSY 4 SCREW WITH HEX HEAD (KOMBI)

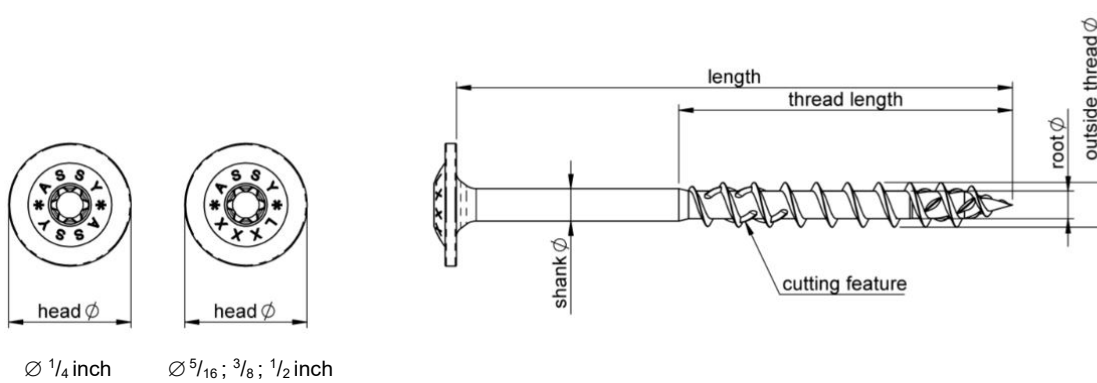

FIGURE 10—ASSY 4 SCREW WITH WASHER HEAD (SK)

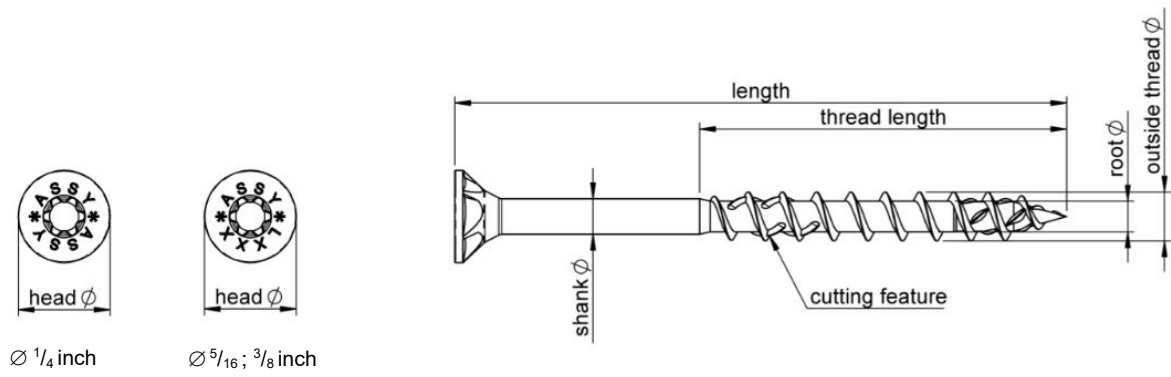

FIGURE 11—ASSY 4 SCREW WITH COUNTERSUNK HEAD WITH MILLING POCKETS (ECO)

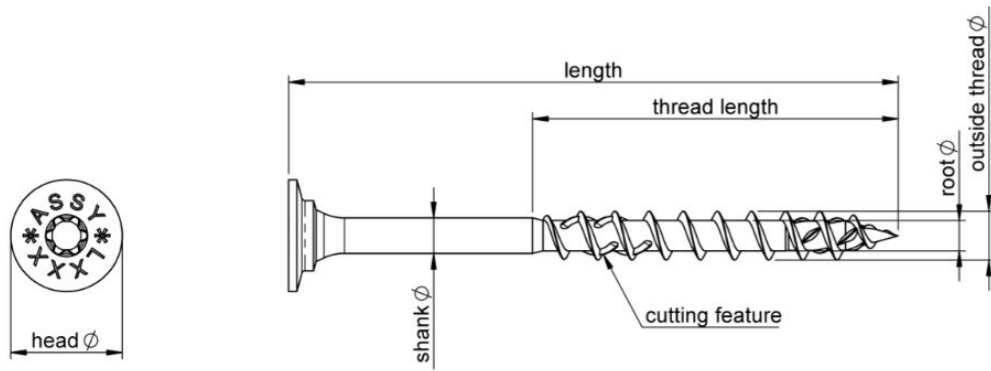

FIGURE 12—ASSY 4 SCREW WITH FLAT WASHER HEAD (FWH OR SK II)