

ICC-ES Evaluation Report

ESR-3105

Reissued August 2023

Revised July 2024

Subject to renewal August 2025

This report also contains:

- LABC Supplement
- CBC Supplement
- FBC Supplement

ICC-ES Evaluation Reports are not to be construed as representing aesthetics or any other attributes not specifically addressed, nor are they to be construed as an endorsement of the subject of the report or a recommendation for its use. There is no warranty by ICC Evaluation Service, LLC, express or implied, as to any finding or other matter in this report, or as to any product covered by the report.

Copyright © 2024 ICC Evaluation Service, LLC. All rights reserved.

<p>DIVISION: 06 00 00— WOOD, PLASTICS AND COMPOSITES</p> <p>Section: 06 05 23— Wood, Plastic, and Composite Fastenings</p>	<p>REPORT HOLDER: MITEK® INC.</p> 	<p>EVALUATION SUBJECT: MITEK Z4 CT CONTINUITY TIE AND T2 TENSION TIE CONNECTORS</p>	
--	--	--	---

1.0 EVALUATION SCOPE

Compliance with the following codes:

- 2024, 2021, 2018, 2015 and 2012 [International Building Code® \(IBC\)](#)
- 2024, 2021, 2018, 2015 and 2012 [International Residential Code® \(IRC\)](#)

For compliance with the codes adopted by the [Los Angeles Department of Building and Safety \(LADBS\)](#), see [ESR-3105 LABC and LARC Supplement](#).

Property evaluated:

- Structural

2.0 USES

The MiTek Z4 CT Continuity Tie and T2 Tension Tie connectors described in this report are mechanical connectors that are capable of transmitting forces induced by parts of wood-framing structures being connected to the element providing the resistance to those forces in accordance with applicable requirements set forth in Chapter 23 of the IBC and Chapter 6 of the IRC. The connectors may also be used in wood-framing structures regulated under the IRC when an engineered design is submitted in accordance with IRC Section R301.1.3.

3.0 DESCRIPTION

3.1 General:

The MiTek Z4 CT Continuity Tie and T2 Tension Tie connectors described in this report consist of steel tubes, steel end plates, all-thread steel rods and the attaching bolts with approved washers and nuts. The steel end plates are on one end of the T2 Tension Tie connectors, and on both ends of the CT Continuity Tie connectors. [Figure 1](#) shows the typical connector dimensions.

The MiTek Z4 CT Continuity Tie and T2 Tension Tie connectors, when attached to wood framing structural members in accordance with [Figures 2](#) through [7](#), transmit tension forces to threaded steel rods. The CT Continuity Tie connectors can also transmit compressive forces when attached to wood framing structural members in accordance with [Figure 2](#).

3.2 Material:

3.2.1 Steel Tubes: The cold-formed, welded steel tubes conform to Chinese National Standard GB/T 6728-2002. Steel used to manufacture steel tubes conforms to Chinese National Standard GB/T 700-2006, Grade Q235, with a minimum yield strength, F_y , of 34,100 psi (235 MPa) and a minimum tensile strength, F_u , of 53,700 psi (370 MPa). The tube section has holes for 20d common nails used to secure the tubes during installation, and holes for placement of ASTM A307 steel bolts used to attach the tubes to a wood member. See [Figure 1](#) for the typical tube configurations.

3.2.2 Steel End Plates: The steel end plates conform to Chinese National Standard GB/T 700-2006, Grade Q235, with a minimum yield strength, F_y , of 34,100 psi (235 MPa) and a minimum tensile strength, F_u , of 59,000 psi (407 MPa). The thickness of the steel end plates ranges from $\frac{3}{8}$ inch to $1\frac{3}{4}$ inches (9.5 mm to 44.5 mm). Each steel end plate has a centered hole for the placement of the threaded steel rod.

3.2.3 All-Thread Steel Rods: The all-thread steel rods must conform to ASTM F1554-07ae1 Grade 36, 55 and 105, ASTM A193-14 Grade B7, ASTM A311-04 (2010) Grade 1045 B, ASTM A354-11 Grade BD, or ASTM A449-10, as specified in this report, and the threads must conform to ANSI B18.1 and have Class 2A tolerance. See [Tables 1](#) through [3](#) for the steel rod size required for each connector.

3.2.4 Bolts: The headed steel bolts used to attach connectors to wood members must conform to ASTM A307 Grade A.

3.2.5 Washers and Nuts: Circular washers and nuts used with the threaded steel rods and bolts attaching the connectors to the wood members must conform to the following ASTM specifications:

3.2.5.1 Circular Washers: ASTM F436-11.

3.2.5.2 Nuts: ASTM A563-07a(2014) Grade A, for ASTM F1554-07ae1 Grade 36 and Grade 55 threaded rods and ASTM A307 bolts; or ASTM A194-14 Grade 2H or ASTM A563-07a(2014) Grade DH for ASTM F1554-07ae1 Grade 105, ASTM A193-14 Grade B7, ASTM A311-04(2010) Grade 1045 B, ASTM A354-11 Grade BD, and ASTM A449-10 threaded rods, respectively.

3.2.6 Threaded Rod Couplers: Threaded rod couplers used to splice the threaded rods or connect the threaded rods to the anchors in the concrete or masonry must comply with the same ASTM specifications that are required for nuts, including specified strength, material matching, dimensions, and thread engagement length. Additionally, couplers shall include a method, such as sight holes, to ensure proper thread engagement for in-field installation.

4.0 DESIGN AND INSTALLATION

4.1 Design:

4.1.1 General: Calculations for the use of the CT connectors, plans detailing the location of the connectors, and the method of attachment to the concrete or masonry, where applicable, must be submitted to the code official for approval. Applied loads resisted by the connector assembly must be determined by structural analysis, and must not exceed the applicable allowable loads given in [Tables 1](#) through [7](#) for the connector assembly. Attachment of the threaded rods to walls or embedment of the threaded rods into concrete foundations must be designed and detailed on the plans by a registered design professional, and must be approved by the code official. Couplers may be used to connect the threaded rods to other threaded rods, concrete or masonry anchors, or other base anchorage, where the anchors have been designed and detailed on the plans by a registered design professional, and approved by the code official.

The allowable loads given in [Tables 1](#) through [7](#) are for allowable stress design (ASD) and include the load duration factor, C_D , corresponding to the applicable loads, and the group action factor, C_g , where applicable, in accordance with the ANSI/AWC *National Design Specification[®] for Wood Construction* (NDS). The allowable loads in [Tables 1](#), [3](#), [5](#), and [7](#) are for the connectors used with visually graded No. 2 or higher grade Douglas Fir-larch solid sawn lumber, except the grade must be No. 1 or higher grade for wood members that are nominally 5-by-5 and larger. The allowable loads for T2 connectors with visually graded No. 1 and higher grade Douglas Fir-larch solid sawn lumber are noted in [Table 5](#).

The applied axial compressive load on wood posts must not exceed the allowable stress design axial compressive load values shown in [Table 7](#), based on the lower of the allowable compression perpendicular-to-grain, $P_{c\perp}$, and the allowable compression parallel-to-grain, $P_{c\parallel}$, of applicable wood members.

The allowable loads in this report are intended for use with the load combinations of Section 1605.1 of the 2024 and 2021 IBC (Section 1605.3 for the 2018, 2015 and 2012 IBC), but may not be increased for material specific behavior in wind or seismic loading. Such behavior has already been considered.

The tabulated allowable loads are for the connectors connecting wood members that are under continuously dry interior conditions, and where sustained temperature is 100°F (37.8°C) or less. The tabulated allowable loads must be adjusted by the temperature factor, C_t , specified in the NDS, when wood members will experience sustained exposure to temperatures exceeding 100°F (37.8°C).

The tabulated allowable loads must be adjusted by the wet service factor, C_M , as specified in the NDS for lateral loads on dowel-type fasteners when the connectors are fastened to solid sawn wood members having moisture content greater than 19 percent, or where wet service is expected.

The tabulated allowable loads must not be adjusted by factors specified in Table A3.2 of AISC 341-22 under the 2024 IBC and IRC [Table A3.1 of AISC 341-16 under the 2021 and 2018 IBC and IRC (Table A3.1 of AISC 341-10 under the 2015 and 2012 IBC and IRC)] for steel end plates of the connectors.

4.1.2 Paired Connectors: The allowable tension loads shown in [Tables 1](#) and [3](#) are for assemblies consisting of a pair of connectors and a single wood member, with a connector installed on the opposing faces of the wood member, as shown in [Figures 2](#) and [3](#), with ASTM A307 bolts used in a double shear connection. The allowable tensile loads of wood members, when in control, must be determined based on the wood member net section and are noted in [Tables 1](#) and [3](#). When paired connectors of CT Continuity Ties are used to resist compressive loads in the anchor rod, the allowable compressive load must be the least of the following: (1) the value from [Table 1](#), (2) the allowable compressive force on the anchor rod shown in [Table 2](#), and (3) the allowable compressive force on the wood member shown in [Table 7](#). In addition, the wood member's design capacity must be checked for the combined axial compressive and flexural stresses in accordance with the applicable code.

4.1.3 Sandwiched Connectors: The allowable tensile loads shown in [Tables 5](#) and [6](#) are for assemblies consisting of two wood members and a single connector installed between the two wood members as shown in [Figure 4](#). The allowable tensile loads of the wood member, when in control, are determined based on the tensile stress in two wood members at their net sections, and are noted in [Table 5](#).

4.2 Installation:

Installation of the connectors must be in accordance with this report and the manufacturer's published installation instructions. In the event of a conflict between this report and the manufacturer's published installation instructions, the more restrictive requirement governs.

The connectors must be installed parallel to the grain of the connected wood members. Bolt holes in the main wood member must be a minimum of $1/32$ inch (0.8 mm) to a maximum of $1/16$ inch (1.6 mm) larger than the bolt nominal diameter. Placement of bolt holes must comply with the NDS for end and edge distances. The connectors must be bolted to the wood member using bolts complying with size and strength requirements noted in [Tables 1](#) through [6](#).

For the CT Continuity Tie connectors, a threaded steel rod must be installed to connect the pair of connectors, or a wall element to a connector, as shown in [Figure 2](#). A loose plate can be added to a T2 connector to form a CT connector when the threaded rod is subject to compressive loads. Nuts must be used to secure the threaded rod at both ends of the connector, as shown in [Figure 2](#). All nuts for the threaded rod must be installed to have a final installation torque of 50 ± 10 lbs-ft (68 ± 14 N-m).

T2 Tension Tie connectors can also be installed in accordance with [Figures 3](#) through [6](#), with a threaded steel rod installed to connect a group of in-line connectors, a foundation or other approved anchor, or a wall element to the connector.

Since the allowable compressive loads in [Table 7](#) are based on the wood member's being continuously braced, the sheathing shown in [Figure 2](#) or the sheathing attached to the compressive post members in hold-down connections must be adequately attached to laterally brace the wood member.

4.3 Special Inspection:

4.3.1 IBC: Periodic special inspection is required for installation of the connectors described in this report that are designated as components of the seismic force-resisting system for structures in Seismic Design Categories C, D, E, and F in accordance with 2024 and 2021 IBC Section 1705.13.2 [2018 and 2015 IBC Section 1705.12.2 (2012 IBC Section 1705.11.2)], excepting those structures that qualify under the Exceptions to 2024, 2021, 2018, 2015, and 2012 IBC Section 1704.2. The special inspector must be present as often as required in accordance with statement of special inspection. The duties of the special inspector include, but are not limited to, verifying compliance with the approved construction documents and the requirements of this evaluation report.

4.3.2 IRC: For installations under the IRC, special inspection is not normally required. However, for an engineered design where calculations are required to be signed by a registered design professional, periodic special inspection requirements and exemptions are as stated in Sections 4.3.1, 5.5, 5.6, and 5.7 of this report, as applicable for installations under the IRC.

5.0 CONDITIONS OF USE:

The MiTek Z4 CT Continuity Tie and T2 Tension Tie connectors described in this report comply with, or are suitable alternatives to what is specified in, those codes listed in Section 1.0 of this report, subject to the following conditions:

- 5.1 The connectors must be manufactured, identified and installed in accordance with this report and the manufacturer's published installation instructions. A copy of the instructions must be available at the jobsite at all times during installation.
- 5.2 Drawings and details verifying compliance with this report must be submitted to the code official for approval. The drawings and calculations must be prepared and signed by a registered design professional when required by the statutes of the jurisdiction in which the project is to be constructed.
- 5.3 Adjustment factors noted in Section 4.1 and the applicable codes must be considered, where applicable. No further duration of load increase for wind and earthquake loading is allowed. Tabulated ASD allowable loads must not be adjusted by values specified in Table A3.2 of AISC 341-22 under the 2024 IBC [Table A3.1 of AISC 341-16 under the 2021 and 2018 IBC (AISC 341-10 under the 2015 and 2012 IBC)] for steel end plates of the connectors.
- 5.4 Use of the connectors and fasteners in contact with preservative-treated wood members and fire-retardant-treated solid sawn wood members is subject to the approval of the code official, since the effect of corrosion of metal in contact with chemically and fire-retardant-treated wood has not been evaluated and is outside the scope of this report.
- 5.5 Anchor bolts of the connector attached to concrete or masonry structural members must be designed and detailed in accordance with applicable code and Section 4.1.1 of this report by a registered design professional. Special inspections for anchor bolts in concrete or masonry shall be conducted in accordance with Section 1705.3 or 1705.4 of the 2024, 2021, 2018, 2015, and 2012 IBC.
- 5.6 Periodic special inspections for seismic and wind resistance shall be conducted in accordance with the appropriate section(s) of Chapter 17 of the IBC.
- 5.7 A statement of special inspection must be prepared by a registered design professional in responsible charge, and submitted to the code official for approval, in accordance with Section 1704.3 of the 2024, 2021, 2018, 2015, and 2012 IBC.
- 5.8 The MiTek Z4 CT Continuity Tie and T2 Tension Tie connectors in this report are manufactured under a quality control program with inspections by ICC-ES.

6.0 EVIDENCE SUBMITTED

Data in accordance with the [ICC-ES Acceptance Criteria for Hold-downs \(Tie-downs\) Attached to Wood Members \(AC155\)](#), dated May 2015 (editorially revised June 2024).

7.0 IDENTIFICATION

- 7.1 The MiTek Z4 CT Continuity Tie and T2 Tension Tie connectors are identified by markings that include the company name (MiTek); the product model designation; and the ICC-ES evaluation report number (ESR-3105).
- 7.2 The report holder's contact information is the following:

MITEK[®] INC.
16023 SWINGLEY RIDGE ROAD
CHESTERFIELD, MISSOURI 63017
(951) 245-9525
www.hardyframe.com

TABLE 1 CT PAIRED CONNECTION ASD CAPACITIES ^{1,6,7,9,10}
DF-L No.2 Grade typ., No.1 @ 5x5 & larger

CT MODEL ²	GRADE 36 ALL-THREAD ROD DIA. (in.) ²	A307 BOLTS QTY. & DIA. (in.)	b ³	CT PAIRED CONNECTION ASD DESIGN CAPACITIES (lbs.)							Δ _s @ STRENGTH FACTORED RESISTANCE ⁸	Δ _{all} @ ALLOWABLE LOAD ⁸
				MINIMUM LENGTH OF BOLT IN WOOD MEMBERS ON EACH SIDE OF CT AND MINIMUM THICKNESS OF WOOD MEMBERS (in.)								
				1½	2½	3	3½	5⅛	5½	7¼ / 7½		
CT-43	½	(4) ¾	3½	5,010	6,989	6,993	6,997	7,004	7,004	7,007	0.189	0.132
CT-24	½	(2) ½	3½	3,360	5,600	6,235	6,235	6,235	6,235	6,235	0.229	0.160
CT-44	⅝	(4) ½	3½	6,637	11,118	12,395	12,405	12,420	12,430	12,457	0.209	0.146
CT-64	¾	(6) ½	3½	7,138 ⁴	11,897 ⁴	14,276 ⁴	16,656 ⁴	18,442	18,504	18,592	0.207	0.145
			5½	9,679	16,395	18,330	18,383	18,442	18,504	18,592		
CT-84	⅞	(8) ½	3½	7,138 ⁴	11,897 ⁴	14,276 ⁴	16,656 ⁴	21,137 ⁴	22,683 ⁴	24,590	0.217	0.152
			5½	10,662 ⁴	17,769 ⁴	21,323 ⁴	24,057	24,241	24,381	24,590		
			7¼ / 7½	12,377	21,300	23,892	24,057	24,241	24,381	24,590		
CT-46	1	(4) ¾	5½	9,749	16,453 ⁴	19,744 ⁴	23,034 ⁴	27,776	27,804	28,028	0.222	0.155
			7¼ / 7½	9,749	16,464	19,817	23,184	27,776	27,804	28,028		
CT-48	1 ⅛	(4) 1	5½	9,345 ⁴	15,576 ⁴	18,691 ⁴	21,806 ⁴	30,020 ⁴	32,216 ⁴	43,240 ⁵	0.232	0.162
			7¼ / 7½	12,029 ⁴	20,048 ⁴	24,057 ⁴	28,067 ⁴	41,858 ⁴	43,240 ⁵	43,240 ⁵		
			9¼ / 9½	12,591	21,513	25,939	30,460	44,910 ⁵	43,240 ⁵	43,240 ⁵		
CT-68	1 ⅜	(6) 1	5½	9,345 ⁴	15,576 ⁴	18,691 ⁴	21,806 ⁴	30,020 ⁴	32,216 ⁴	43,931 ⁴	0.211	0.148
			7¼ / 7½	12,029 ⁴	20,048 ⁴	24,057 ⁴	28,067 ⁴	41,858 ⁴	46,736 ⁴	63,731 ⁴		
			9¼ / 9½	14,590 ⁴	24,317 ⁴	29,180 ⁴	34,044 ⁴	49,850 ⁴	50,119 ⁴	64,593 ⁵		
			11¼ / 11½	16,504 ⁴	27,506 ⁴	33,008 ⁴	38,509 ⁴	56,388 ⁴	61,999 ⁴	64,593 ⁵		
			13¼ / 13½	16,622	29,652	36,167	42,901	64,541	64,593 ⁵	64,593 ⁵		

For SI: 1 inch (in) = 25.4mm, 1 pound=4.45N

¹ Wood design capacities have been increased by a 1.60 load duration factor (C_D).

² Two CT models and two all-thread rods are required per connection (one on either side of post).

³ Minimum required width of attached member between devices.

⁴ Design capacity controlled by the tension capacity of the net cross-section of wood member at bolts.

⁵ These capacities are limited by all-thread rod tension design capacity.

⁶ The minimum end distance, from the end of the wood member to the centerline of the first CT bolt, is seven (7) CT bolt diameters. End distance may be increased with no decrease in design capacities.

⁷ The capacity of the concrete or masonry anchor must be equal to or greater than the design capacity of the connector being specified.

⁸ Deflections at loads less than P_s or P_{all} may be determined by multiplying by the ratio of the lesser load to the maximum load. Strength factored resistance is the tabulated P_{all} times 1.4. Tabulated displacement consists of deformation and rotation of the hold-down (tie-down), and fastener slip (bolt rotation) of the bolts used to attach the hold-down (tie-down) to the wood member. Shrinkage of supporting wood members and all-thread rod elongation shall be the responsibility of the registered design professional.

⁹ Hold-downs used in series shall account for the cumulative deformation of all hold-downs (tie-downs) within said series.

¹⁰ The assembly must have an allowable strength equal to or greater than the required strength of the assembly under the action of the allowable load combinations referenced in the applicable code.

**TABLE 2 ALL-THREAD ROD ASD DESIGN TENSION & COMPRESSION CAPACITIES
FOR TWO ASTM F1554 GRADE 36 ALL-THREAD RODS (lbs.)^{4,6}**

L ² (in.)	K ³	ALL-THREAD ROD DIAMETER D _r (in.) ¹							
		(2) 1/2	(2) 5/8	(2) 3/4	(2) 7/8	(2) 1	(2) 1 1/8	(2) 1 1/4	(2) 1 3/8
		ALL-THREAD ROD TENSION CAPACITIES, P _{RT} (lbs.)							
		8,541	13,346	19,218	26,157	34,165	43,240	53,383	64,593
		ALL-THREAD ROD COMPRESSION CAPACITIES, P _{RC} (lbs.)							
12	1.00	3,200	6,448	10,741	15,863	21,724	28,188	36,689	44,400
18		1,478 ⁵	3,746 ⁵	7,778	12,684	18,333	24,596	32,868	40,397
24		830 ⁵	2,108 ⁵	4,616 ⁵	8,795	14,252	20,313	28,347	35,681
30		532 ⁵	1,348 ⁵	2,954 ⁵	5,630 ⁵	9,690 ⁵	15,317	23,134	30,279
36		370 ⁵	936 ⁵	2,052 ⁵	3,910 ⁵	6,728 ⁵	10,684 ⁵	17,224 ⁵	24,162
42		272 ⁵	688 ⁵	1,508 ⁵	2,872 ⁵	4,944 ⁵	7,850 ⁵	12,654 ⁵	17,970 ⁵

For SI: 1 inch (in) = 25.4 mm, 1 pound = 4.45 N

¹ All-thread rod must comply with ASTM F1554 Grade 36.

² Unsupported length of all-thread rod shown in Figure 2.

³ K is the slenderness factor. A K value of 1.00 is used for pinned ends.

⁴ When using the CT connector to transfer compression loads the design engineer shall check the wood members design capacity for the most critical load combination (i.e. bending about one or both principal axes and axial compression)

⁵ When $K L / r > C_c$ or 200, $F_a = 12\pi^2 E / 23 (K L / r)^2$, where $r = (D_r - 0.9743/n)$, and $n =$ thread per inch, $C_c = (2\pi^2 E / F_y)^{1/2}$, where $F_y =$ yield strength of all-thread rod steel and $E =$ modulus of elasticity of all-thread rod steel.

⁶ The tabulated allowable capacities are applicable for designs complying with Sections 12.10 and 12.11.2 of ASCE 7.

TABLE 3 T2 PAIRED CONNECTION ASD CAPACITIES ^{1,6,7,9,10}

DF-L No.2 Grade typ., No.1 @5x5 & larger

T2 MODEL ²	MIN GRADE 36 ALL-THREAD ROD DIA. (in.) ²	A307 BOLTS QTY. & DIA. (in)	b ³	T2 PAIRED CONNECTION ASD DESIGN CAPACITIES (lbs.)							Δ _s @ STRENGTH FACTORED RESISTANCE ⁸	Δ _{all} @ ALLOWABLE LOAD ⁸
				MINIMUM LENGTH OF BOLT IN WOOD MEMBERS ON EACH SIDE OF T2 AND MINIMUM THICKNESS OF WOOD MEMBERS (in.)								
				1½	2½	3	3½	5⅛	5½	7¼ / 7½		
T2-43	1/2	(4) 3/8	3 1/2	5,010	6,989	6,993	6,997	7,004	7,004	7,007	0.189	0.132
T2-24	1/2	(2) 1/2	3 1/2	3,360	5,600	6,235	6,235	6,235	6,235	6,235	0.229	0.160
T2-44	5/8	(4) 1/2	3 1/2	6,637	11,118	12,395	12,405	12,420	12,430	12,457	0.209	0.146
T2-64	3/4	(6) 1/2	3 1/2	7,138 ⁴	11,897 ⁴	14,276 ⁴	16,656 ⁴	18,442	18,504	18,592	0.207	0.145
			5 1/2	9,679	16,395	18,330	18,383	18,442	18,504	18,592		
T2-84	7/8	(8) 1/2	3 1/2	7,138 ⁴	11,897 ⁴	14,276 ⁴	16,656 ⁴	21,137 ⁴	22,683 ⁴	24,590	0.217	0.152
			5 1/2	10,662 ⁴	17,769 ⁴	21,323 ⁴	24,057	24,241	24,381	24,590		
			7 1/4 / 7 1/2	12,377	21,300	23,892	24,057	24,241	24,381	24,590		
T2-46	1	(4) 3/4	5 1/2	9,749	16,453 ⁴	19,744 ⁴	23,034 ⁴	27,776	27,804	28,028	0.222	0.155
			7 1/4 / 7 1/2	9,749	16,464	19,817	23,184	27,776	27,804	28,028		
T2-48	1 1/8	(4) 1	5 1/2	9,345 ⁴	15,576 ⁴	18,691 ⁴	21,806 ⁴	30,020 ⁴	32,216 ⁴	43,240 ⁵	0.232	0.162
			7 1/4 / 7 1/2	12,029 ⁴	20,048 ⁴	24,057 ⁴	28,067 ⁴	41,858 ⁴	43,240 ⁵	43,240 ⁵		
			9 1/4 / 9 1/2	12,591	21,513	25,939	30,460	44,910 ⁵	43,240 ⁵	43,240 ⁵		
T2-68	1 3/8	(6) 1	5 1/2	9,345 ⁴	15,576 ⁴	18,691 ⁴	21,806 ⁴	30,020 ⁴	32,216 ⁴	43,931 ⁴	0.211	0.148
			7 1/4 / 7 1/2	12,029 ⁴	20,048 ⁴	24,057 ⁴	28,067 ⁴	41,858 ⁴	46,736 ⁴	63,731 ⁴		
			9 1/4 / 9 1/2	14,590 ⁴	24,317 ⁴	29,180 ⁴	34,044 ⁴	49,850 ⁴	50,119 ⁴	64,593 ⁵		
			11 1/4 / 11 1/2	16,504 ⁴	27,506 ⁴	33,008 ⁴	38,509 ⁴	56,388 ⁴	61,999 ⁴	64,593 ⁵		
			13 1/4 / 13 1/2	16,622	29,652	36,167	42,901	64,541	64,593 ⁵	64,593 ⁵		

For SI: 1 inch (in) = 25.4 mm, 1 pound = 4.45 N

¹ Wood design capacities have been increased by a 1.60 load duration factor (C_D).

² Two T2 models and two all-thread rods are required per connection (one on either side of post).

³ Minimum required width of attached member between devices.

⁴ Design capacity controlled by the tension capacity of the net cross-section of wood member at bolts.

⁵ These capacities are limited by the all-thread rod tension design capacity.

⁶ The minimum end distance, from the end of the wood member to the centerline of the first T2 bolt, is seven (7) T2 bolt diameters. End distance may be increased with no decrease in design capacities.

⁷ The capacity of the concrete or masonry anchor must be equal to or greater than the design capacity of the connector being specified.

⁸ Deflections at loads less than P_s or P_{all} may be determined by multiplying by the ratio of the lesser load to the maximum load. Strength factored resistance is the tabulated P_{all} times 1.4. Tabulated displacement consists of deformation and rotation of the hold-down (tie-down), and fastener slip (bolt rotation) of the bolts used to attach the hold-down (tie-down) to the wood member. Shrinkage of supporting wood members and all-thread rod elongation shall be the responsibility of the registered design professional.

⁹ The user should note that hold-downs used in series shall account for the cumulative deformation of all hold-downs (tie-downs) within said series.

¹⁰ The assembly must have an allowable strength equal to or greater than required strength of the assembly under the action of the allowable load combinations referenced in the applicable code.

TABLE 4 ALL-THREAD ROD ASD DESIGN TENSION CAPACITIES FOR TWO ASTM F1554 GRADE 36 ALL-THREAD RODS (lbs.)^{1,2}

ALL-THREAD ROD DIAMETER D _r (in.) ¹							
(2) 1/2	(2) 5/8	(2) 3/4	(2) 7/8	(2) 1	(2) 1 1/8	(2) 1 1/4	(2) 1 3/8
TENSION CAPACITIES (lbs.)							
8,541	13,346	19,218	26,157	34,165	43,240	53,383	64,593

For SI: 1 inch (in) = 25.4 mm, 1 pound = 4.45 N

¹ All-thread rod must comply with ASTM F1554 Grade 36.

² The tabulated ASD capacities are applicable for designs complying with Sections 12.10 and 12.11.2 of ASCE 7.

TABLE 5 T2-SANDWICH CONNECTION (wood posts each side) ASD CAPACITIES^{1,6,7,10,11} DF-L No.1 or better (2x4) & No.2 Grade typ., except No.1 @5x5 & larger

T2 MODEL	MIN HS ALL-THREAD ROD DIA. (in.) ²	A307 BOLTS QTY. & DIA. (in)	B ³	T2 SANDWICH CONNECTION ASD DESIGN CAPACITIES (lbs.)							Δ _s @ STRENGTH FACTORED RESISTANCE ⁹	Δ _{all} @ ALLOWABLE LOAD ⁹
				MINIMUM LENGTH OF BOLT IN WOOD MEMBERS ON EACH SIDE OF T2 AND MINIMUM THICKNESS OF WOOD MEMBERS (in.)								
				1 1/2 No.1+	1 1/2	2 1/2	3	3 1/2	5 1/8	≥ 5 1/2		
T2-43	1/2	(4) 3/8	3 1/2	6,457	6,457	7,001	7,001	7,005	7,007	7,009	0.145	0.102
T2-24	1/2	(2) 1/2	3 1/2	4,984	4,984	6,235	6,235	6,235	6,235	6,235	0.121	0.085
T2-44	5/8	(4) 1/2	3 1/2	9,904	9,904	12,422	12,432	12,436	12,445	12,449	0.152	0.108
T2-64	3/4	(6) 1/2	3 1/2	14,637	14,276 ⁴	18,465	18,499	18,533	18,573	18,597	0.179	0.128
			5 1/2	14,637	14,637	18,465	18,499	18,533	18,573	18,597		
T2-84	7/8	(8) 1/2	3 1/2	16,920 ⁴	14,276 ⁴	23,417 ⁸	23,417 ⁸	23,417 ⁸	23,417 ⁸	23,417 ⁸	0.181	0.129
			5 1/2	19,077	19,077	23,417 ⁸	23,417 ⁸	23,417 ⁸	23,417 ⁸	23,417 ⁸		
T2-46	1	(4) 3/4	5 1/2	19,385 ⁸	19,385 ⁷	19,385 ⁸	19,385 ⁸	19,385 ⁸	19,385 ⁸	19,385 ⁸	0.159	0.114
T2-48S	1 1/8	(4) 1	5 1/2	22,152 ⁴	18,691 ⁴	31,151 ⁴	37,382 ⁴	42,141	42,867 ⁵	42,867 ⁵	0.172	0.122
			7 1/4 / 7 1/2	25,963	24,057 ⁴	36,671	39,152	42,141	42,867 ⁵	42,867 ⁵		
T2-68S	1 3/8	(6) 1	5 1/2	22,152 ⁴	18,691 ⁴	31,151 ⁴	37,382 ⁴	43,612 ⁴	64,036 ⁵	64,036 ⁵	0.210	0.150
			7 1/4 / 7 1/2	30,888 ⁴	24,057 ⁴	40,095 ⁴	48,114 ⁴	56,133 ⁴	64,036 ⁵	64,036 ⁵		
			9 1/4 / 9 1/2	36,171	31,833 ⁴	52,474	56,276	61,061	64,036 ⁵	64,036 ⁵		

For SI: 1 inch (in) = 25.4 mm, 1 pound = 4.45 N

¹ Wood design capacities have been increased by a 1.60 load duration factor (C_D).

² All-thread rod must comply with ASTM F1554 Grade 105.

³ Minimum required width of attached member between devices.

⁴ Design capacity controlled by the tension capacity of the net cross-section of wood member at bolts.

⁵ These capacities are limited by the all-thread rod tension design capacity.

⁶ The minimum end distance, from the end of the wood member to the centerline of the first T2 bolt, is seven (7) T2 bolt diameters. End distance may be increased with no decrease in design capacities.

⁷ The capacity of the concrete or masonry anchor must be equal to or greater than the design capacity of the connector being specified.

⁸ The tabulated ASD capacities are a measure of steel strength of the device when tested on a steel jig with a safety factor of 2.5 applied to the lowest maximum test load.

⁹ Deflections at loads less than P_s or P_{all} may be determined by multiplying by the ratio of the lesser load to the maximum load. Strength factored resistance is the tabulated P_{all} times 1.4. Tabulated displacement consists of deformation and rotation of the hold-down (tie-down), and fastener slip (bolt rotation) of the bolts used to attach the hold-down (tie-down) to the wood member. Shrinkage of supporting wood members and all-thread rod elongation shall be the responsibility of the registered design professional.

¹⁰ The user should note that hold-downs used in series shall account for the cumulative deformation of all hold-downs (tie-downs) within said series.

¹¹ The assembly must have an allowable strength equal to or greater than required strength of the assembly under the action of the ASD load combinations referenced in the applicable code.

TABLE 6 T2-SANDWICH CONNECTION (wood posts each side)
ASD CAPACITIES (for use by component manufacturers only) ^{2,3,5}

T2 MODEL	END PLATE THICKNESS (in.)	ALL-THREAD ROD DIA. (in.) ¹	A307 BOLTS QTY. & DIA. (in.)	MAXIMUM CAPACITIES BASED ON DEVICE AND ASSEMBLY TESTS (lbs.) ²	Δ_{all} @ ALLOWABLE LOAD ⁴	
					$\Delta_{all-DF-L}$	$P_{all-DF-L}$
T2-1	$\frac{3}{8}$	$\frac{1}{2}$ - $\frac{5}{8}$	(4) $\frac{3}{8}$	10,973	0.104	7,009
T2-2	$\frac{3}{8}$	$\frac{5}{8}$ - 1	(2) $\frac{1}{2}$	9,985	0.087	6,235
T2-3	$\frac{3}{8}$	$\frac{5}{8}$ - 1	(4) $\frac{1}{2}$	9,985	0.087	9,985
T2-4	$\frac{1}{2}$	$\frac{5}{8}$ - 1	(6) $\frac{1}{2}$	15,289	0.105	15,289
T2-5	$\frac{5}{8}$	$\frac{5}{8}$ - 1	(8) $\frac{1}{2}$	17,556	0.097	17,556
T2-6	$\frac{1}{2}$	$\frac{7}{8}$ - $1\frac{1}{4}$	(4) $\frac{3}{4}$	19,385	0.114	19,385
T2-7	$\frac{1}{2}$	1 - $1\frac{3}{8}$	(2) 1	18,361	0.053	18,361
T2-8	1	1 - $1\frac{3}{8}$	(4) 1	38,770	0.111	38,770
T2-9	$1\frac{1}{2}$	1 - $1\frac{3}{8}$	(6) 1	51,755	0.121	51,755

For SI: 1 inch (in) = 25.4 mm, 1 pound = 4.45 N

¹ All-thread rod must comply with ASTM F1554 Grade 105.

² Design capacity may be controlled by the net section tension capacity of the wood member. Capacities for bolts in wood members shall be calculated using the NDS, Section 11.3. Final design capacity shall be the minimum of the NDS calculated or the Table 6 capacity. Wood design capacities may be increased by a 1.60 load duration factor (C_D).

³ The capacity of the concrete or masonry anchor must be equal to or greater than the design capacity of the connector being specified.

⁴ Deflections at loads less than maximum P_{all} may be determined by multiplying by the ratio of the lesser load to the maximum load. Strength factored resistance is the tabulated P_{all} times 1.4. Tabulated displacement consists of deformation and rotation of the hold-down (tie-down), and fastener slip (bolt rotation) of the bolts used to attach the hold-down (tie-down) to the wood member. Shrinkage of supporting wood members and all-thread rod elongation shall be the responsibility of the registered design professional.

⁵ The user should note that hold-downs used in series shall account for the cumulative deformation of all hold-downs (tie-downs) within said series.

**TABLE 7- COMPRESSION DESIGN CAPACITIES (lbs.) for WOOD STUDS or POSTS¹
DF-L, No.2 typ., No.1 @ 5x5 and larger**

b ⁵ (in.)	l _e (in.)	C _D ⁶	P _{CL} ^{2,4} or P _C ³	t (in.), LENGTH OF BOLT IN WOOD MEMBER ⁷							
				1 ½	2	2 ½	3	3 ½	5 ½	7 ¼	
3 ½		1.00	P _{CL} max	3,281	4,375	5,469	6,563	7,656	12,031	15,859	
		1.60		-	-	-	-	-	-	-	
	91.5	1.00	P _C max	3,234	4,312	5,390	6,468	7,546	11,764	15,369	
		1.60		3,367	4,489	5,611	6,733	7,856	12,280	16,093	
	103.5	1.00	P _C max	2,619	3,492	4,366	5,239	6,112	9,551	12,513	
		1.60		2,694	3,592	4,490	5,389	6,287	9,843	12,921	
	115.5	1.00	P _C max	2,152	2,869	3,586	4,303	5,020	7,857	10,311	
		1.60		2,197	2,929	3,662	4,394	5,126	8,033	10,557	
	127.5	1.00	P _C max	1,793	2,390	2,988	3,586	4,183	6,553	8,609	
		1.60		1,822	2,429	3,037	3,644	4,251	6,666	8,766	
	5 ½		1.00	P _{CL} max	5,156	6,875	8,594	10,313	12,031	18,906	25,781
			1.60		-	-	-	-	-	-	-
91.5		1.00	P _C max	8,885	11,847	14,809	17,771	20,733	25,802	35,185	
		1.60		10,329	13,772	17,215	20,657	24,100	31,792	43,353	
103.5		1.00	P _C max	7,930	10,574	13,217	15,860	18,504	24,201	33,001	
		1.60		8,873	11,831	14,788	17,746	20,704	28,877	39,378	
115.5		1.00	P _C max	6,968	9,291	11,614	13,937	16,260	22,346	30,472	
		1.60		7,569	10,092	12,615	15,138	17,661	25,782	35,158	
127.5		1.00	P _C max	6,077	8,103	10,129	12,155	14,181	20,347	27,746	
		1.60		6,463	8,618	10,772	12,927	15,081	22,770	31,050	
139.5		1.00	P _C max	5,294	7,058	8,823	10,588	12,352	18,337	25,005	
		1.60		5,549	7,398	9,248	11,097	12,947	20,017	27,296	
7 ¼ / 7 ½		1.00	P _{CL} max	6,797	9,063	11,328	13,594	15,859	25,781	35,156	
		1.60		-	-	-	-	-	-	-	
	103.5	1.00	P _C max	12,475	16,634	20,792	24,950	29,109	37,417	51,023	
		1.60		15,252	20,337	25,421	30,505	35,589	47,638	64,961	
	115.5	1.00	P _C max	11,730	15,640	19,550	23,461	27,371	36,243	49,422	
		1.60		13,918	18,557	23,196	27,835	32,474	45,365	61,862	
	127.5	1.00	P _C max	10,887	14,516	18,145	21,775	25,404	34,849	47,521	
		1.60		12,528	16,704	20,880	25,056	29,232	42,723	58,259	
	139.5	1.00	P _C max	9,989	13,319	16,648	19,978	23,308	33,237	45,323	
		1.60		11,180	14,907	18,633	22,360	26,087	39,793	54,263	
	163.5	1.00	P _C max	8,222	10,963	13,704	16,444	19,185	29,486	40,208	
		1.60		8,833	11,778	14,722	17,667	20,611	33,622	45,849	
187.5	1.00	P _C max	6,701	8,935	11,169	13,403	15,637	25,455	34,712		
	1.60		7,028	9,370	11,713	14,055	16,398	27,891	38,034		

For SI: 1 inch (in) = 25.4 mm, 1 pound = 4.45 N

¹ Tables are for axial compression load only and are for the design capacity of one wood member.

² P_{CL} max= Maximum Design Capacity in Compression Perpendicular to Grain, based on an allowable compression perpendicular to grain stress of 625 psi (load duration factor C_D not applicable).

³ P_C max= Maximum Design Capacity in Compression Parallel to Grain, with effective length of member = l_e (l_e / b ≤ 50).

⁴ P_{CL} max may be multiplied by C_b for bearings not nearer than 3 inches to the end of a member:

t (in.) ⁷	1.50	2.00	2.50	3.00	3.50	5.50	≥6.00
C _b	1.25	1.17	1.15	1.13	1.11	1.07	1.00

⁵ Minimum required width of attached member between devices.

⁶ C_D = load duration factor.

⁷ t = thickness (width) of stud or post, braced dimension.

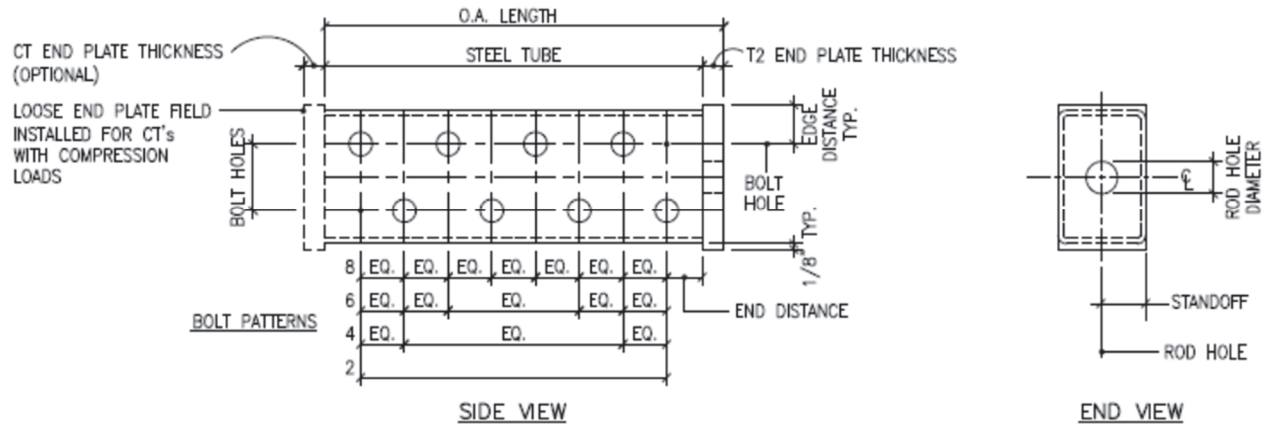

CT,T2 Model	TUBE SIZE (in.)	T2 OAL (in.)	CT OAL (in.)	EDGE DISTANCE (in.)	END DISTANCE (in.)	STANDOFF (in.)	BOLTS			END PLATES		
							NUMBER	HOLE DIA. (in.)	STAGGERED SPACING (in.)	T2 END PLATES	CT END PLATES	ATR HOLE DIA. (in.)
43-4	2 1/2 x 2 1/2 x 1/8	4 7/8	5 1/4	7/8	3/4	1 1/4	4	7/16	1	3/8	3/8	9/16
24-4	3 x 3 x 1/8	2 7/8	3 1/4	1	3/4	1 1/2	2	9/16	1	3/8	3/8	9/16
44-5	3 x 3 x 1/8	5	5 1/2	1	3/4	1 1/2	4	9/16	1	1/2	1/2	1 1/16
64-6E	3 x 3 x 1/8	7 1/8	7 3/4	1	3/4	1 1/2	6	9/16	1	5/8	5/8	1 3/16
84-7	3 x 3 x 1/8	9 1/4	10	1	3/4	1 1/2	8	9/16	1	3/4	3/4	1 5/16
46-8	4 x 3 x 3/16	7 1/4	7 3/4	1 1/4	1 1/8	1 1/2	4	1 3/16	1 1/2	1/2	1/2	1 1/16
48-9	5 x 3 x 3/16	9 5/8	10 1/4	1 1/2	1 1/2	1 1/2	4	1 1/16	2	5/8	5/8	1 3/16
68-11	5 x 3 x 3/16	14	15	1 1/2	1 1/2	1 1/2	6	1 1/16	2	1	1	1 7/16
48-9S	5 x 3 x 3/16	10 3/8	-	1 1/2	1 1/2	1 1/2	4	1 1/16	2	1 3/8	-	1 3/16
68-11S	5 x 3 x 3/16	14 3/4	-	1 1/2	1 1/2	1 1/2	6	1 1/16	2	1 3/4	-	1 7/16

For SI: 1 inch (in) = 25.4 mm

FIGURE 1 - CT AND T2 CONNECTOR CONFIGURATION & DIMENSIONS

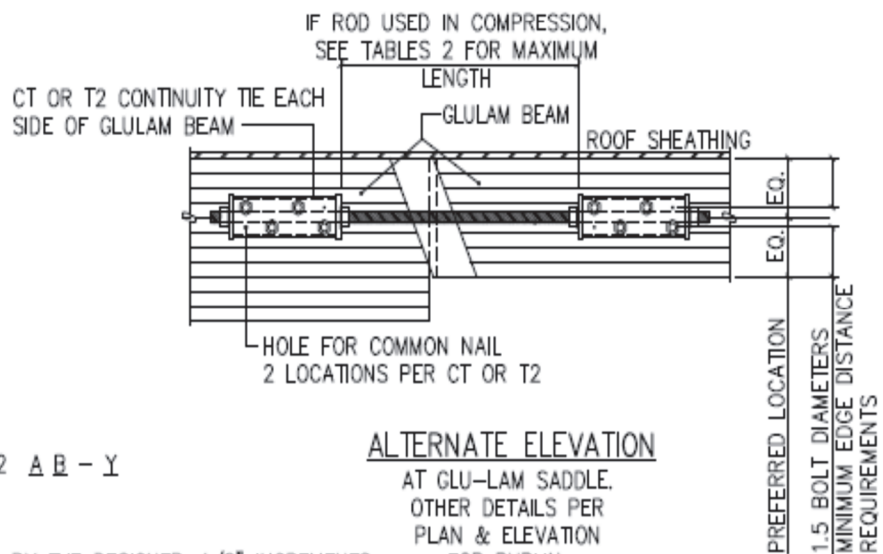
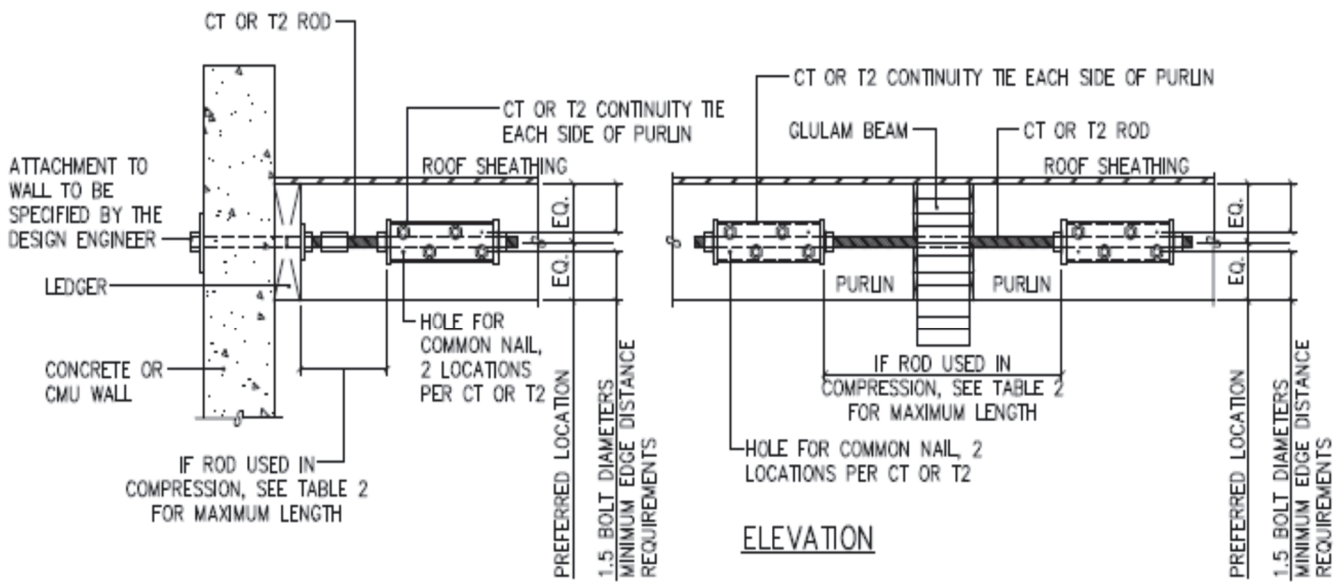
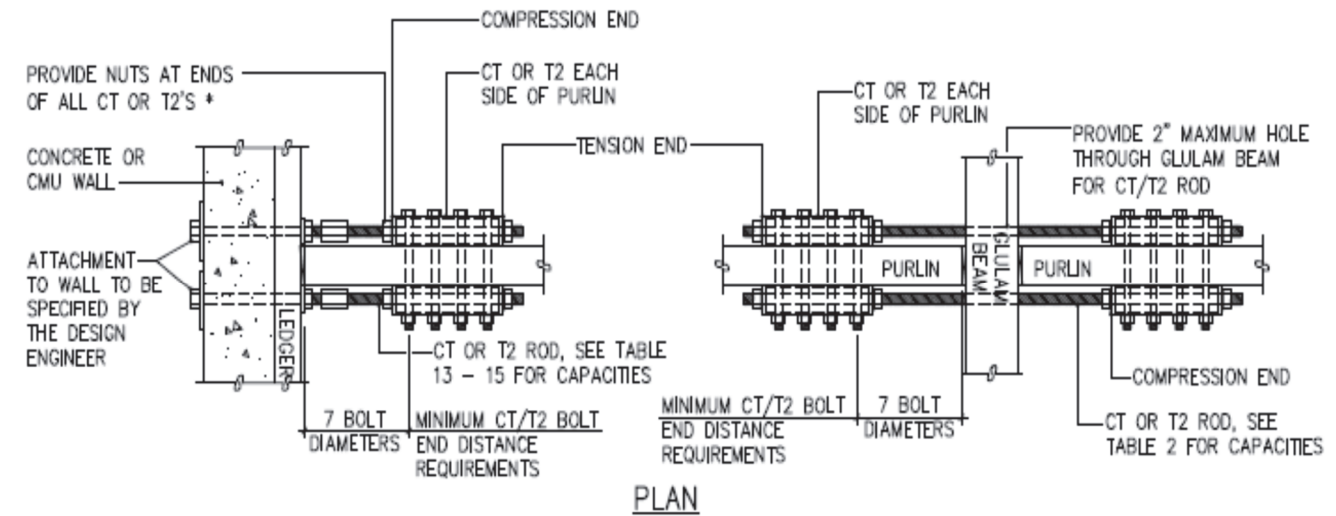

CT/T2 MODEL LEGEND: CT OR T2 A B - Y

A = QUANTITY OF BOLTS

B = BOLT SIZE, 1/8" INCREMENTS

Y = THREADED ROD SIZE SPECIFIED BY THE DESIGNER, 1/8" INCREMENTS

FIGURE 2—TYPICAL ROOF CONNECTIONS USING CT OR T2 CONNECTOR

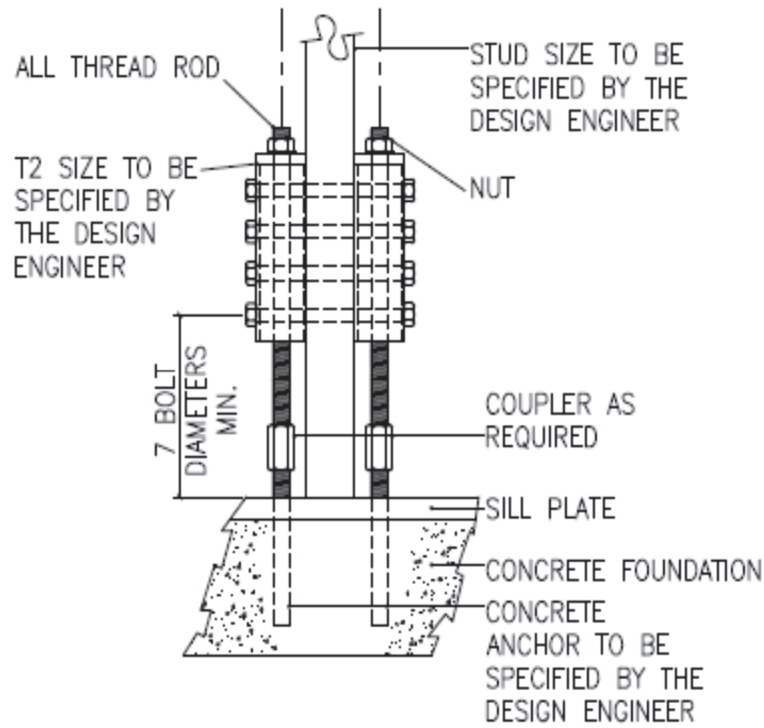

FIGURE 3—PAIRED CONNECTION

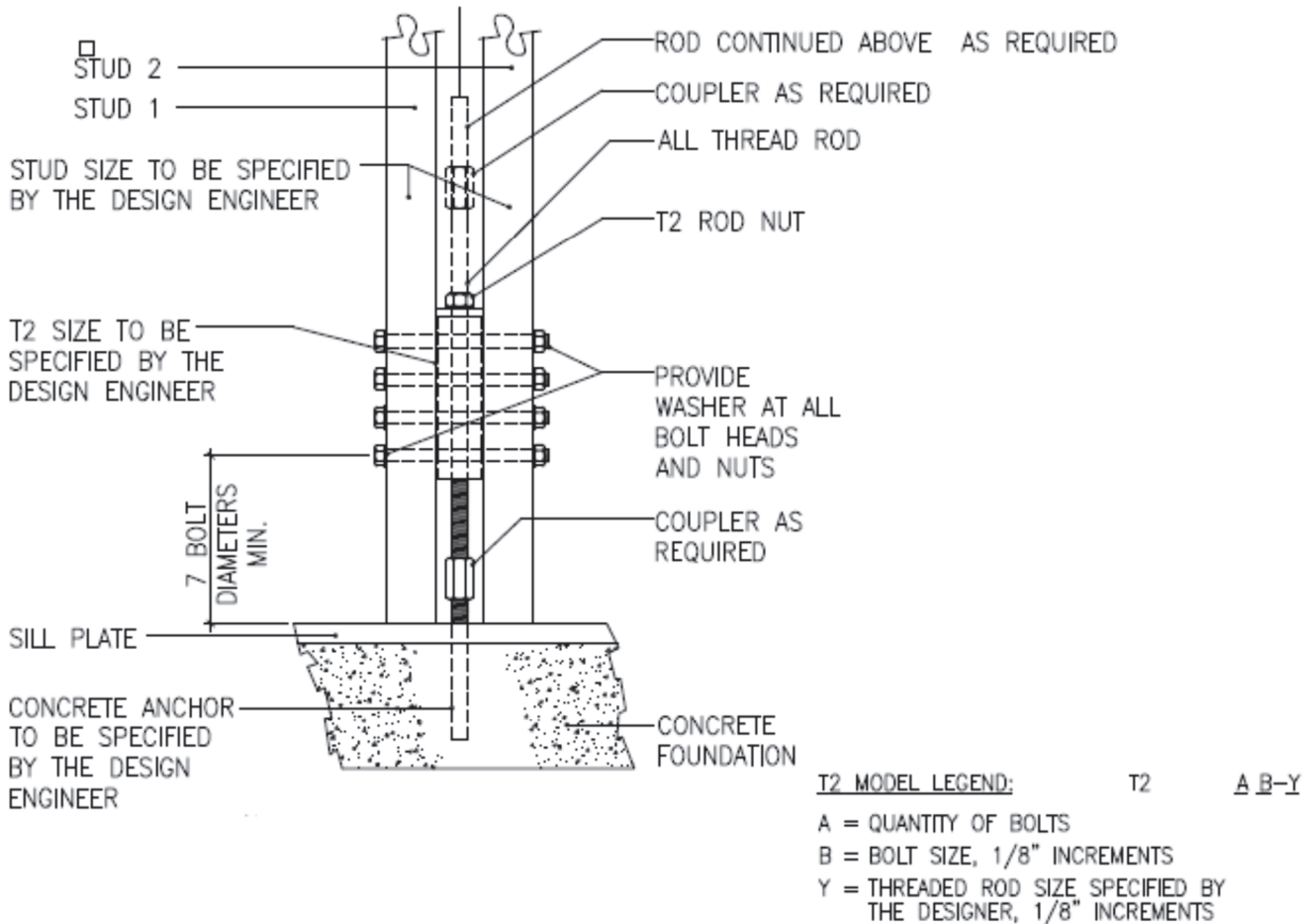

FIGURE 4—SANDWICH CONNECTION

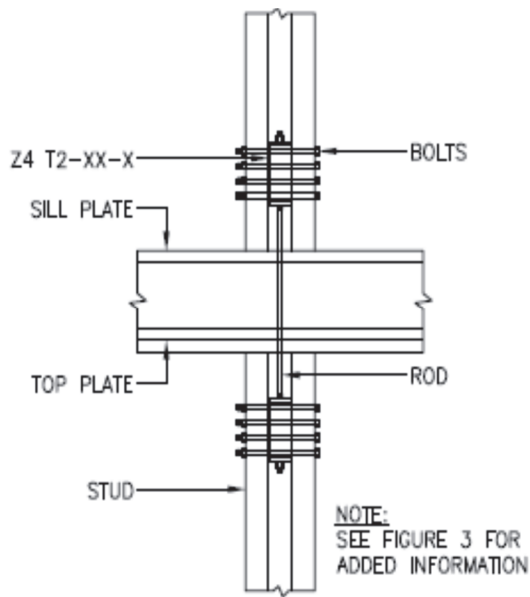

FIGURE 5—SANDWICH CONNECTION ABOVE AND BELOW RAISED FLOOR

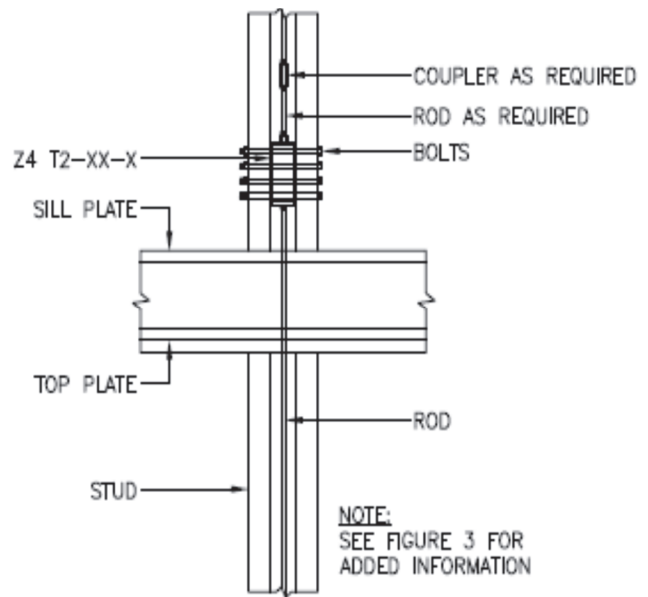

FIGURE 6—SANDWICH CONNECTION AT RAISED FLOOR TO CONTINUOUS ROD

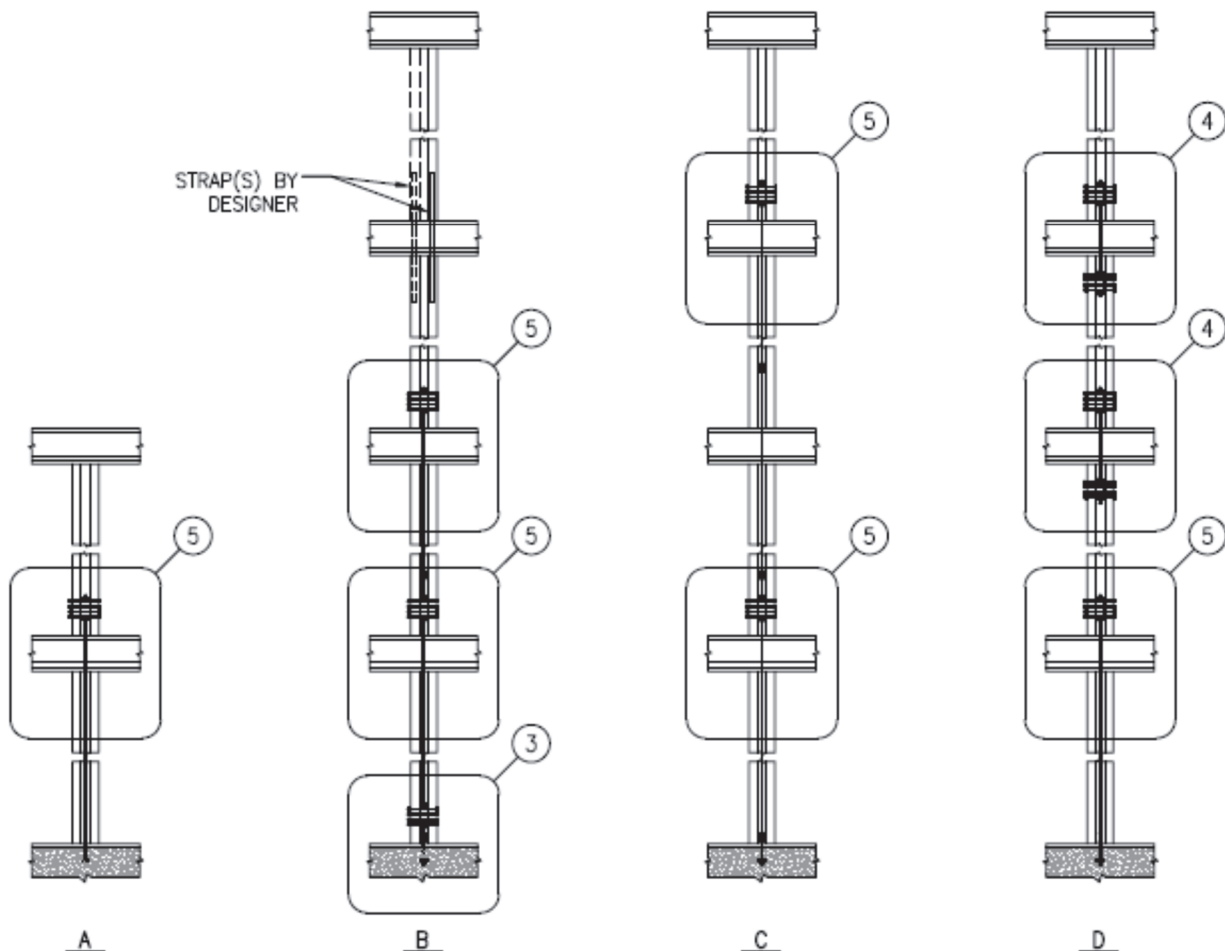

FIGURE 7—MULTI-LEVEL SANDWICH CONNECTION SAMPLE COMBINATIONS

DIVISION: 06 00 00—WOOD, PLASTICS AND COMPOSITES
Section: 06 05 23—Wood, Plastic, and Composite Fastenings

REPORT HOLDER:

MITEK® INC.

EVALUATION SUBJECT:

MITEK Z4 CT CONTINUITY TIE AND T2 TENSION TIE CONNECTORS

1.0 REPORT PURPOSE AND SCOPE

Purpose:

The purpose of this evaluation report supplement is to indicate that the MiTek Z4 CT Continuity Tie and T2 Tension Tie Connectors, described in ICC-ES evaluation report [ESR-3105](#), have also been evaluated for compliance with the codes noted below as adopted by the Los Angeles Department of Building and Safety (LADBS).

Applicable code editions:

- 2023 *City of Los Angeles Building Code* (LABC)
- 2023 *City of Los Angeles Residential Code* (LARC)

2.0 CONCLUSIONS

The MiTek Z4 CT Continuity Tie and T2 Tension Tie Connectors, described in Sections 2.0 through 7.0 of the evaluation report [ESR-3105](#), comply with the LABC Chapter 23, and the LARC, and are subjected to the conditions of use described in this supplement.

3.0 CONDITIONS OF USE

The MiTek Z4 CT Continuity Tie and T2 Tension Tie Connectors described in this evaluation report supplement must comply with all of the following conditions:

- All applicable sections in the evaluation report [ESR-3105](#).
- The design, installation, conditions of use and identification of the MiTek Z4 CT Continuity Tie and T2 Tension Tie Connectors are in accordance with the 2021 *International Building Code*® (IBC) provisions noted in the evaluation report [ESR-3105](#).
- The design, installation and inspection are in accordance with additional requirements of LABC Chapters 16 and 17, and Sections 2305 and 2306, as applicable.
- Under the LARC, an engineered design in accordance with LARC Section R301.1.3 must be submitted.
- In accordance with LABC Section 2305.5, allowable seismic load values of the MiTek Z4 CT Continuity Tie and T2 Tension Tie connectors used as hold-down connectors must be 75 percent of those in the evaluation report [ESR-3105](#).
- The seismic design provisions for hillside buildings referenced in LABC Section 2301.1 have not been considered and are outside of the scope of this supplement.
- The seismic design provisions in accordance with City of Los Angeles Information Bulletin P/BC 2020-071 for the design of wall anchorage assemblies to flexible diaphragms, have not been considered, and are outside of the scope of this supplement.

This supplement expires concurrently with the evaluation report, reissued August 2023 and revised July 2024.

DIVISION: 06 00 00—WOOD, PLASTICS AND COMPOSITES
Section: 06 05 23—Wood, Plastic, and Composite Fastenings

REPORT HOLDER:

MITEK® INC.

EVALUATION SUBJECT:

MITEK Z4 CT CONTINUITY TIE AND T2 TENSION TIE CONNECTORS

1.0 REPORT PURPOSE AND SCOPE

Purpose:

The purpose of this evaluation report supplement is to indicate that MiTek Z4 CT Continuity Tie and T2 Tension Tie Connectors, described in ICC-ES report ESR-3105, have also been evaluated for compliance with the code(s) noted below.

Applicable code edition:

- 2022 California Building Code (CBC)

For evaluation of applicable Chapters adopted by the California Office of Statewide Health Planning and Development (OSHPD), AKA: California Department of Health Care Access and Information (HCAI), and the Division of State Architect (DSA), see Sections 2.1.1 and 2.1.2 below.

- 2022 California Residential Code (CRC)

2.0 CONCLUSIONS

2.1 CBC:

The MiTek Z4 CT Continuity Tie and T2 Tension Tie Connectors, described in Sections 2.0 through 7.0 of the evaluation report ESR-3105, comply with CBC Chapter 23, provided the design and installation are in accordance with the 2021 *International Building Code*® (IBC) provisions noted in the evaluation report and the additional requirements of CBC Chapters 16, 17 and 23, as applicable.

2.1.1 OSHPD:

The applicable OSHPD Sections and Chapters of the CBC are beyond the scope of this supplement.

2.1.2 DSA:

The applicable DSA Sections and Chapters of the CBC are beyond the scope of this supplement.

2.2 CRC:

The MiTek Z4 CT Continuity Tie and T2 Tension Tie Connectors, described in Sections 2.0 through 7.0 of the evaluation report ESR-3105, comply with CRC Chapter 3, provided the design and installation are in accordance with the 2021 *International Residential Code*® (IRC) provisions noted in the evaluation report.

This supplement expires concurrently with the evaluation report, reissued August 2023 and revised July 2024.

DIVISION: 06 00 00—WOOD, PLASTICS AND COMPOSITES
Section: 06 05 23—Wood, Plastic, and Composite Fastenings

REPORT HOLDER:

MITEK® INC.

EVALUATION SUBJECT:

MITEK Z4 CT CONTINUITY TIE AND T2 TENSION TIE CONNECTORS

1.0 REPORT PURPOSE AND SCOPE**Purpose:**

The purpose of this evaluation report supplement is to indicate that MiTek Z4 CT Continuity Tie and T2 Tension Tie connectors, described in ICC-ES evaluation report ESR-3105, have also been evaluated for compliance with the codes noted below.

Applicable code editions:

- 2023 Florida Building Code—Building
- 2023 Florida Building Code—Residential

2.0 CONCLUSIONS

The MiTek Z4 CT Continuity Tie and T2 Tension Tie connectors, described in Sections 2.0 through 7.0 of ICC-ES evaluation report ESR-3105, comply with the *Florida Building Code—Building* and *Florida Building Code—Residential*, provided the design requirements are must be in accordance with the *Florida Building Code—Building* or the *Florida Building Code—Residential*, as applicable. The installation requirements noted in ICC-ES evaluation report ESR-3105 for the 2021 *International Building Code*® meet the requirements of the *Florida Building Code—Building* or the *Florida Building Code—Residential*, as applicable.

Use of the MiTek Z4 CT Continuity Tie and T2 Tension Tie connectors has also been found to be in compliance with the High-Velocity Hurricane Zone provisions of the *Florida Building Code—Building* and *Florida Building Code—Residential* with the following condition:

- a. For connections subject to uplift, the connection must be designed for no less than 700 pounds (3114 N).

For products falling under Florida Rule 61G20-3, verification that the report holder's quality assurance program is audited by a quality assurance entity approved by the Florida Building Commission for the type of inspections being conducted is the responsibility of an approved validation entity (or the code official when the report holder does not possess an approval by the Commission).

This supplement expires concurrently with the evaluation report, reissued August 2023 and revised July 2024.