

ICC-ES Evaluation Report

ESR-1860

Reissued December 2023

This report also contains:

- CBC Supplement

Subject to renewal December 2025

- NCC Supplement

ICC-ES Evaluation Reports are not to be construed as representing aesthetics or any other attributes not specifically addressed, nor are they to be construed as an endorsement of the subject of the report or a recommendation for its use. There is no warranty by ICC Evaluation Service, LLC, express or implied, as to any finding or other matter in this report, or as to any product covered by the report.

Copyright © 2023 ICC Evaluation Service, LLC. All rights reserved.

<p>DIVISION: 31 00 00— EARTHWORK</p> <p>Section: 31 31 16— Termite Control</p>	<p>REPORT HOLDER: TMA CORPORATION, PTY, LTD.</p>	<p>EVALUATION SUBJECT: TERMIMESH™ TERMITE CONTROL SYSTEM</p>	
--	---	---	---

1.0 EVALUATION SCOPE

1.1 Compliance with the following codes:

- 2018, 2015, 2012 and 2009 [International Building Code® \(IBC\)](#)
- 2018, 2015, 2012 and 2009 [International Residential Code® \(IRC\)](#)
- 2013 *Abu Dhabi International Building Code (ADIBC)*†

†The ADIBC is based on the 2009 IBC. 2009 IBC code sections referenced in this report are the same sections in the ADIBC.

Other Codes (see Section 8.0)

Property evaluated:

- Protection against termites

1.2 Evaluation to the following green code(s):

- 2020, 2015, 2012 and 2008 [ICC 700 National Green Building Standard™](#) (ICC 700-2020, ICC 700-2015, ICC 700-2012 and ICC 700-2008)

Attributes verified:

See Section 2.0

2.0 USES

The Termimesh™ Termite Control System is used to provide protection against subterranean termites.

The attributes of the Termimesh™ Termite Control System have been verified as conforming to the provisions of (i) ICC 700-2020, ICC 700-2015, ICC 700-2012 Sections 602.1.5 and 11.602.1.5; and (ii) ICC 700-2008 Section 602.7 for termite barriers. Note that decisions on compliance for those areas rest with the user of this report. The user is advised of the project-specific provisions that may be contingent on upon meeting specific conditions, and the verification of those conditions is outside the scope of this report. These codes or standards often provide supplemental information as guidance.

3.0 DESCRIPTION

3.1 General:

The Termimesh™ Termite Control System is designed to stop subterranean termites from entering a building, by blocking any entrances through the foundation. The foundation entry points of a building include all

construction and control joints, cavity walls below grade, retaining walls, service pipe penetrations through slabs, blockouts in concrete, and brick/block piers. The system consists of a stainless steel mesh, stainless steel clamps and Termiparge (a specialized bonding cement) or Termibond (a specialized epoxy resin). The stainless steel mesh provides a physical barrier with mesh holes small enough to prohibit the passage of a termite. The clamps and Termiparge or Termibond are used to close off any openings in the mesh around pipes and joints. The mesh is either cast into the concrete during the pour or bonded to concrete or masonry using the Termiparge specialized cement-based adhesive or Termibond specialized epoxy resin, which bonds the mesh to concrete or masonry as parging.

3.2 Materials:

3.2.1 Termimesh™: Marine grade stainless steel mesh of a grade not lower than Type 316 (UNS S31600) made from 0.18-millimeter-diameter wire with mesh openings of 0.66 mm by 0.45 mm. Termimesh is supplied in widths of 1200 mm and lengths of 30 m (47.24 inches by 100 feet).

3.2.2 Clamps: Stainless Steel Type 301 (UNS S30100).

3.2.3 Termiparge: Specialized bonding cement which bonds the mesh to concrete, masonry, or other termite-resistant substrates.

3.2.4 Epoxy Resins—Termibond: Specialized epoxy resins used for bonding of mesh to concrete, masonry, steel and galvanized or zinc alum-coated steel substrates.

4.0 INSTALLATION

4.1 General:

The Termimesh™ Termite Control System must be installed in accordance with the manufacturer's published installation instructions and this report. The system must be installed by installers trained and accredited by TMA Corporation, Pty, Ltd. (Refer to Section 4.3.)

Locations requiring protection from termites are described in Section 2304.12.4 of the 2018 and 2015 IBC, Section 2304.11.6 of the 2012 and 2009 IBC, Section 2603.8 of the 2018 and 2015 IBC, Section 2603.9 of the 2012 IBC, and Section 2603.8 of the 2009 IBC; Section R318.1(5), Section R318.3, and R318.4 of the 2018, 2015, 2012, and 2009 IRC.

The manufacturer's published installation instructions and this report must be strictly adhered to, and a copy of the instructions must be available at all times on the jobsite during installation.

If there are any conflicts between the manufacturer's instructions and this report, this report governs.

4.2 Typical Installation:

The Termimesh™ System can be installed under the slab, on ground, in cavity walls, on the outside perimeter of cavity walls, as a cold-joint installation between existing structures, over concrete masonry units and new slabs, and in timber post-supported structures. The mesh is joined by a 10- to 15-millimeter (0.39 to 0.59 inch) physical lap joint (two and a half times as shown in the TMA Corporation, Pty, Ltd., training manual). This joint can be strengthened by using a hot-glue gun every 500 to 1000 millimeters (19.69 to 39.37 inches) along the joint.

Sealing pipe penetrations through concrete slabs is achieved by star-cutting a hole, smaller than the pipe diameter, in the mesh and then stretching the mesh over the pipe to form a collar. The collar is secured by a stainless steel clamp to the pipe.

Shrinkage surface cracks in concrete slabs are not considered to be at risk from termite entry. However, the decision to protect cracks with mesh, Termiparge or Termibond is at the discretion of an accredited Termimesh supervisor. (Refer to Section 4.3.)

Typical details of installations are shown in [Figure 1](#). Complete details for different construction methods are included in the manufacturer's installation instructions.

Accredited Installers:

Installation of the Termimesh™ Termite Control System must only be performed by accredited installers who have undergone extensive training on both how to install the system and understanding the habits of termites. The quality control program is administered by TMA Corporation, Pty, Ltd.

There are seven levels of installer accreditation, each of which is valid for two years and not subject to automatic reissuance. Installers can lose their accreditation or be downgraded depending on their field performance during the accreditation period. Throughout the two-year accreditation period, every installer is

checked on a regular basis, usually every six weeks, by a quality control officer employed by TMA Corporation, Pty, Ltd. The quality control officer can lower the level of an installer's accreditation; or, in extreme circumstances, have the accreditation revoked.

5.0 CONDITIONS OF USE:

The Termimesh™ Termite Control System described in this report complies with, or is a suitable alternative to what is specified in, those codes listed in Section 1.0 of this report, subject to the following conditions:

- 5.1 The barrier system must be installed by installers trained and accredited by TMA Corporation, Pty, Ltd.
- 5.2 On the exterior of the building, the barrier system must be located 3 inches (76 mm) or more measured vertically from the ground, concrete steps, porch slabs, patio slabs and similar horizontal surfaces exposed to the weather. (Refer to [Figures 2](#) and [5](#), Visual Inspection Zone).
- 5.3 The steel mesh must not be installed in contact with reinforcing steel or any dissimilar metals that will produce an electrolytic reaction.
- 5.4 The steel mesh must not be penetrated except by accredited installers.
- 5.5 When required by the applicable code, protection of wood and wood-based products against decay must be provided in accordance with the applicable code.
- 5.6 A TMA Corporation, Pty, Ltd., Protection Notice Label must be located in a conspicuous location on the structure, e.g., at the meter box or electrical circuit breaker box. The label must include the telephone number and address for TMA Corporation, Pty, Ltd., and the name of the accredited installer. The label must provide the following instructions:
 - The Termimesh™ Termite Control System must be inspected three months after completion of the installation and once a year every year thereafter.
- 5.7 Any utility installed in the building after the Termimesh™ Termite Control System is installed must enter the building above the barrier. The Termimesh™ Termite Control System products are manufactured in Amphur Muang, Lamphun, Thailand; and Perth, Western Australia, Australia under a quality-control program with inspections by ICC-ES.

6.0 EVIDENCE SUBMITTED

Data in accordance with the [ICC-ES Acceptance Criteria for Termite Physical Barrier Systems \(AC380\)](#), dated October 2014 (Editorially Revised May 2018).

7.0 IDENTIFICATION

- 7.1 Each roll of Termimesh Termite Control System mesh, and each package of Termiparge, Temibond and stainless steel clamps covered by this report, must bear a label with the manufacturer's name (TMA Corporation, Pty, Ltd.) and address, the product name (Termimesh), and the ICC-ES evaluation report number (ESR-1860).
- 7.2 The report holder's contact information is the following:

TMA CORPORATION, PTY, LTD.
48 CENTURY ROAD
MALAGA, WESTERN AUSTRALIA 6090
AUSTRALIA
+61 (0)8 9249 3868
www.termimesh.com

8.0 OTHER CODES

In addition to the codes referenced in Section 1.0, the products described in this report were evaluated for compliance with the requirements of the following earlier editions of the International Codes:

- 2006 *International Building Code*® (2006 IBC)
- 2006 *International Residential Code*® (2006 IRC)

The Termimesh™ Termite Control System complies with, or is a suitable alternative to what is specified in, the 2006 IBC and 2006 IRC, just as described in Sections 2.0 through 7.0, except that Section 4.1 must be revised to read as follows:

Locations requiring protection from termites are described in Sections 2304.11.6 and 2603.8 of the 2006 IBC, and Sections R320.1(5), R320.4, and R320.5 of the 2006 IRC.

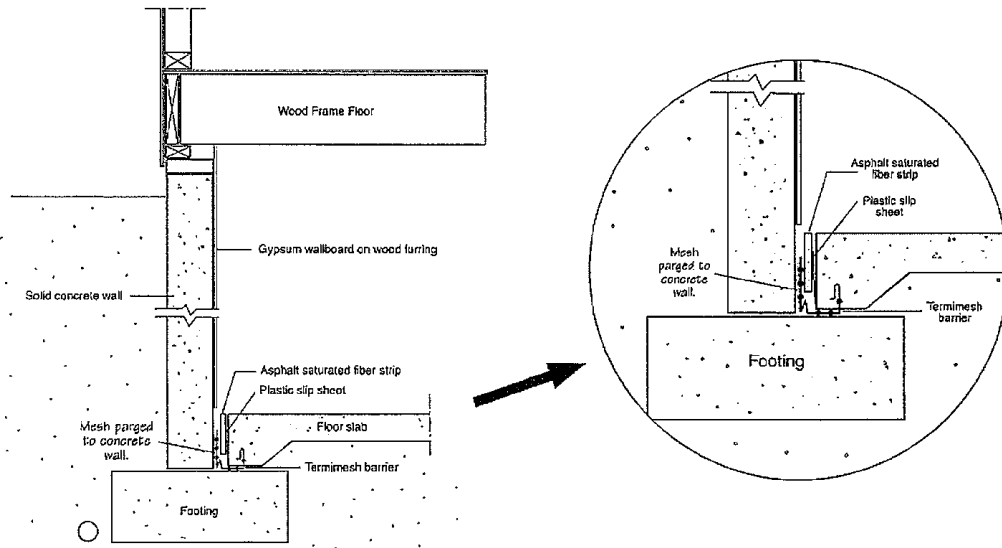

FIGURE 1—TYPICAL INSTALLATION DETAILS
INFILL SLAB BELOW GRADE
CONCRETE WALL

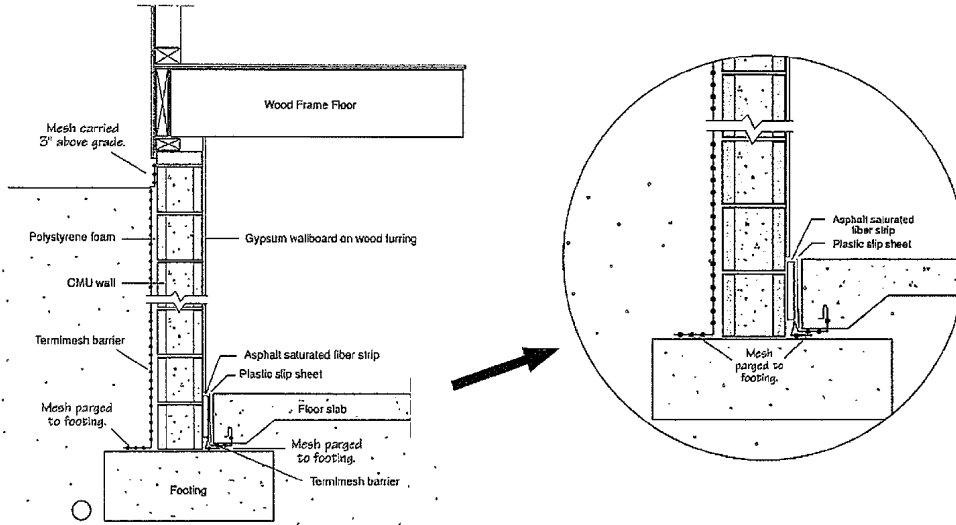
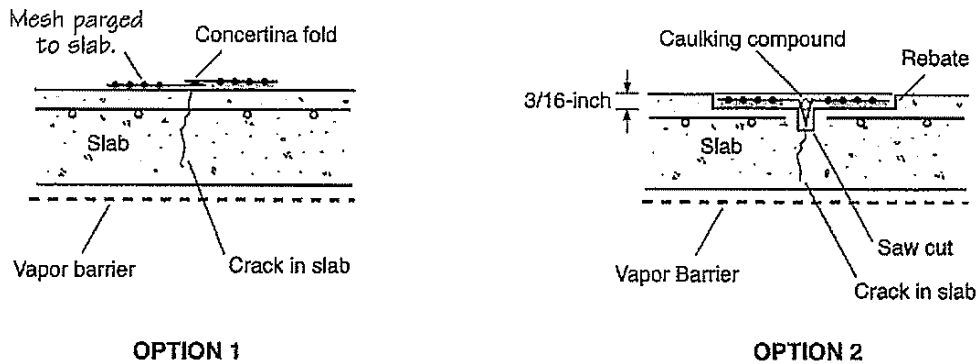

FIGURE 2—INFILL SLAB BELOW GRADE ICF CLAD CMU WALL



OPTION 1

OPTION 2

FIGURE 3—FRACTURED SLAB PROTECTION

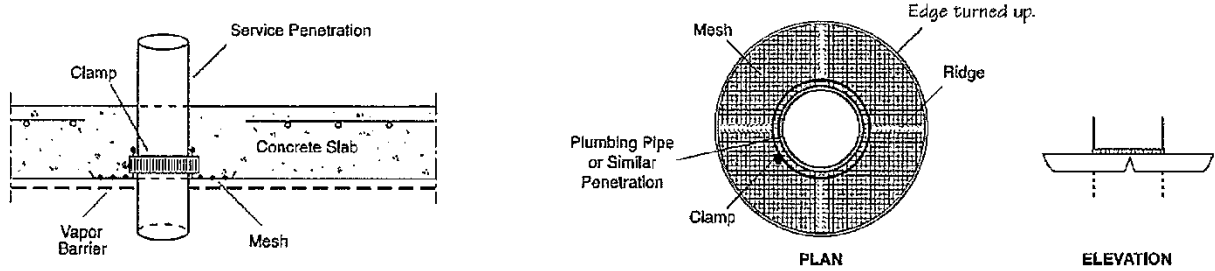

NOTE: Mesh is turned up at the outside edge to be embedded in concrete. The flange is installed such that it does not interfere with the vapor barrier.

**FIGURE 4—PENETRATION PROTECTION
BASE OF SLAB—PRE-POUR**

Where the CMU wall is on a monolithic slab then there will be no requirement for an additional barrier provided that the visual inspection zone is sufficient to readily detect termites attempting to bridge it.

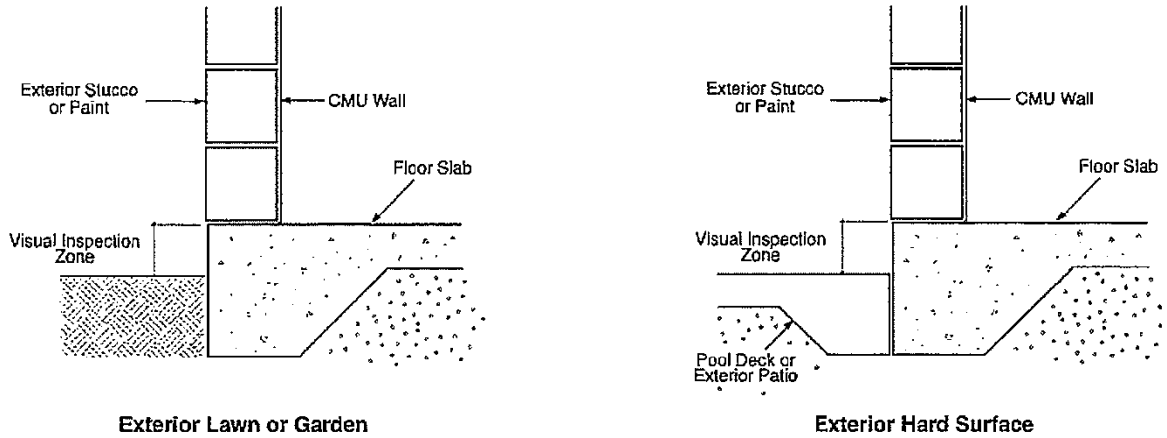

Where the finished grade is soil, garden or lawn, then a 4-inch inspection zone is recommended due to the possible build-up of leaf, litter, etc.

Where the finished grade is a hard surface such as a path or pool deck, then the visual inspection zone may be reduced to 3-inch.

Note that where the wall is clad with timber siding it is recommended to keep the base of the siding a minimum of 4 inches above the final grade to maintain a comprehensive inspection zone, whether the exterior surface is hard or soft.

**FIGURE 5—VISUAL INSPECTION ZONE
MONOLITHIC SLAB**

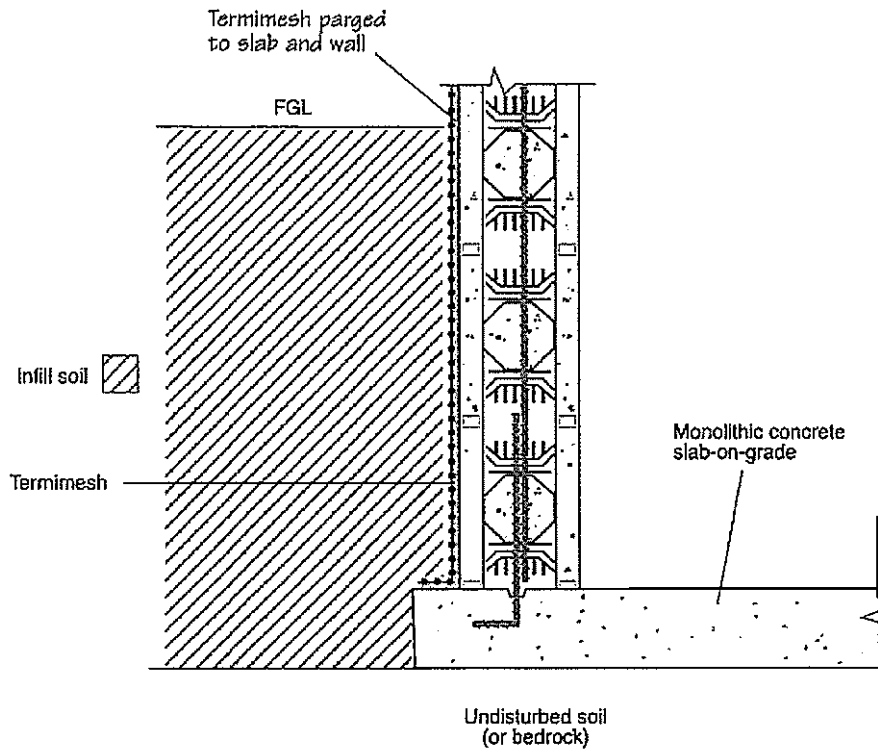
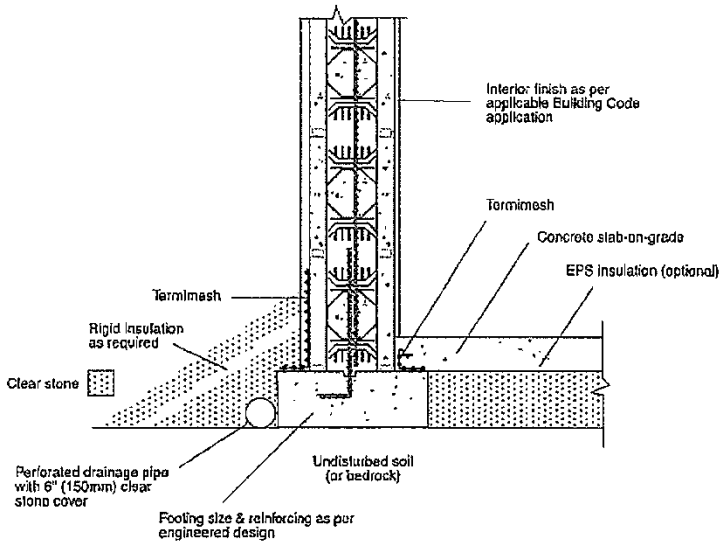
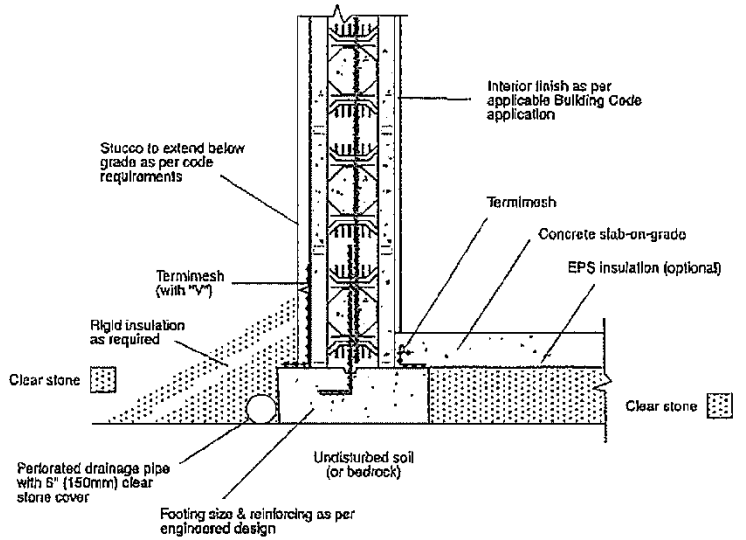

FIGURE 6—ICF WALL PROTECTION (U.S.)
MONOLITHIC SLAB



Method for thin external coating



Method for thick external render

FIGURE 7—ICF WALL PROTECTION (U.S.)
BLOCK SET ON FOOTING

Infill Slabs

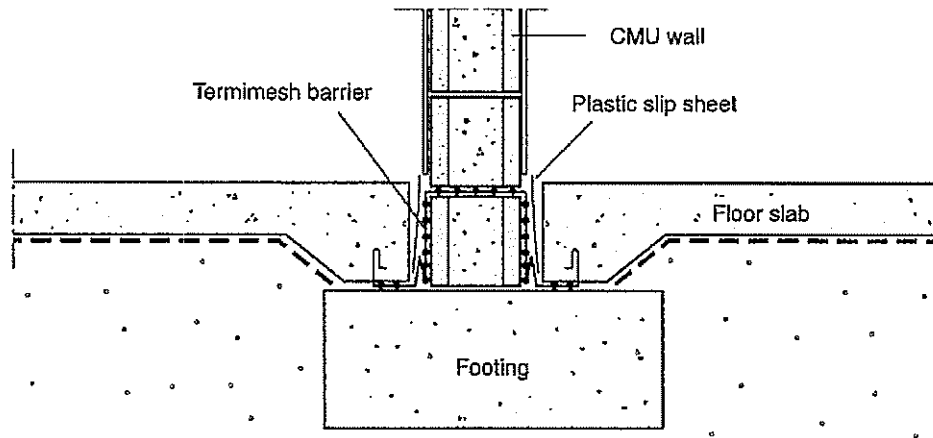
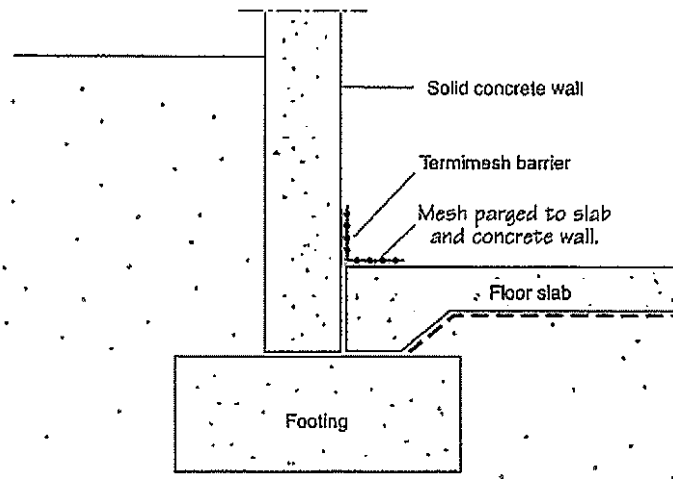

FIGURE 8—INTERIOR CMU WALL
INFILL SLABS



NOTE: Vertical construction joints in concrete wall to be protected.

FIGURE 9—INFILL SLAB BELOW GRADE
POST-POUR

DIVISION: 31 00 00—EARTHWORK
Section: 31 31 16—Termite Control

REPORT HOLDER:

TMA CORPORATION, PTY, LTD.

EVALUATION SUBJECT:

TERMIMESH™ TERMITES CONTROL SYSTEM

1.0 REPORT PURPOSE AND SCOPE**Purpose:**

The purpose of this evaluation report supplement is to indicate that the Termimesh™ Termite Control System, described in the ICC-ES evaluation report ESR-1860, have also been evaluated for compliance with the codes noted below.

Applicable code editions:

- 2019 and 2016 *California Building Code* (CBC)

For evaluation of applicable chapters adopted by the California Office of Statewide Health Planning and Development (OSHPD) AKA: California Department of Health Care Access and Information (HCAI) and the Division of State Architect (DSA), see sections 2.1.1 and 2.1.2 below.

- 2019 and 2016 *California Residential Code* (CRC)

2.0 CONCLUSIONS**2.1 CBC:**

The Termimesh™ Termite Control System, described in Sections 2.0 through 7.0 of the ICC-ES evaluation report ESR-1860, complies with the CBC Chapters 23 and 26, provided the design and installation are in accordance with the 2018 and 2015 *International Building Code*® (IBC) provisions noted in the evaluation report.

2.1.1 OSHPD:

The applicable OSHPD Sections of the CBC are beyond the scope of this supplement.

2.1.2 DSA:

The applicable DSA Sections of the CBC are beyond the scope of this supplement.

2.2 CRC:

The Termimesh™ Termite Control System, described in Sections 2.0 through 7.0 of the ICC-ES evaluation report ESR-1860, complies with the CRC Chapter 3, provided the design and installation are in accordance with the 2018 and 2015 *International Residential Code*® (IRC) provisions noted in the evaluation report.

This supplement expires concurrently with the evaluation report, reissued December 2023.

DIVISION: 31 00 00—EARTHWORK
Section: 31 31 16—Termite Control

REPORT HOLDER:

TMA CORPORATION, PTY, LTD.

EVALUATION SUBJECT:

TERMIMESH™ TERMITES CONTROL SYSTEM

1.0 REPORT PURPOSE AND SCOPE

Purpose:

The purpose of this evaluation report supplement is to provide evidence of suitability that Termimesh™ Termite Control System, described in ICC-ES evaluation report [ESR-1860](#), has also been evaluated for compliance with the code noted below.

Applicable code edition:

National Construction Code (NCC) 2019 Building Code of Australia (BCA)—Volumes One and Two

2.0 CONCLUSIONS

2.1 Building Code of Australia—Volume One:

The Termimesh™ Termite Control System, described in Sections 2.0 through 7.0 of the evaluation report [ESR-1860](#), complies with the *Building Code of Australia—Volume One*, provided the design and installation requirements are determined in accordance with Table 1.

2.2 Building Code of Australia—Volume Two:

The Termimesh™ Termite Control System, described in Sections 2.0 through 7.0 of the evaluation report [ESR-1860](#), complies with the *Building Code of Australia—Volume Two*, provided the design and installation requirements are determined in accordance with Table 1.

TABLE 1—CODE PROVISION COMPLIANCE

Complies with the following Building Code of Australia (BCA) provisions and State or Territory variations			BCA (2019 + A1)	
	VOLUME ONE ¹		VOLUME TWO ¹	
Performance Requirement	BP1.1(b)(xv)	Termite Actions	P2.1.1 (b)(xv)	Termite Actions
State or Territory Variations	—	—	QLD P2.1.3	Queensland
Deemed to Satisfy Provision(s)	B1.4(i)	Termite risk management	3.1.4.3	Termite Management System
State or Territory Variations	NT B1.4(i)	Northern Territory	3.1.4.3	Queensland Northern Territory

¹Under the governing requirements for evidence of suitability in accordance with Part A5 – Documentation of design and construction.

This supplement expires concurrently with the evaluation report, reissued December 2023.