

ICC-ES Evaluation Report

ESR-1763

Reissued May 2024

Subject to renewal May 2026

ICC-ES Evaluation Reports are not to be construed as representing aesthetics or any other attributes not specifically addressed, nor are they to be construed as an endorsement of the subject of the report or a recommendation for its use. There is no warranty by ICC Evaluation Service, LLC, express or implied, as to any finding or other matter in this report, or as to any product covered by the report.

Copyright © 2024 ICC Evaluation Service, LLC. All rights reserved.

<p>DIVISION: 07 00 00—THERMAL AND MOISTURE PROTECTION</p> <p>Section: 07 41 00—Roof Panels</p> <p>Section: 07 41 13—Metal Roof Panels</p>	<p>REPORT HOLDER: ROSER CO., LTD.</p>	<p>EVALUATION SUBJECT: ROSER STEEL AND COPPER ROOFING PANELS</p>	
--	---	--	---

1.0 EVALUATION SCOPE

1.1 Compliance with the following codes:

- 2018, 2015, 2012, 2009, and 2006 [International Building Code® \(IBC\)](#)
- 2018, 2015, 2012, 2009, and 2006 [International Residential Code® \(IRC\)](#)

Properties evaluated:

- Roof covering
- Wind resistance
- Fire classification

2.0 USES

The Roser Steel and Copper Roofing Panels described in this report are metal roof panels complying with IBC Section 1507.5 and IRC Section R905.4 that are used in Class A roof covering assemblies when installed over new and existing roofs.

3.0 DESCRIPTION

3.1 Steel Panels:

The steel panels have a base-metal thickness of 0.0157 inch (0.40 mm) and are formed from aluminum-zinc alloy coated structural quality sheet steel complying with ASTM A792 and having an AZ50 (AZM150) coating designation. On the exposed surface of the steel panels, stone granules are embedded into an acrylic resin adhesive emulsion. See [Figure 1](#) for panel profiles.

3.1.1 Roser Bond and Cleo: The Roser Bond and Cleo panels are 16.14 inches (410 mm) wide by 53.15 inches (1350 mm) long, with an exposure of 14.57 inches (370 mm). The installed weight is approximately 1.5 psf (7.3 kg/m²).

3.1.2 Spany: The Spany steel panels are 16.14 inches (410 mm) wide by 52.56 inches (1335 mm) long, with an exposure of 14.57 inches (370 mm). The installed weight is approximately 1.5 psf (7.3 kg/m²).

3.1.3 Rowood, Stonewood Shake and Piano: The Rowood, Stonewood Shake and Piano panels are 16.14 inches (410 mm) wide by 52.76 inches (1340 mm) long, with an exposure of 14.57 inches (370 mm). The installed weight is approximately 1.5 psf (7.3 kg/m²).

3.2 Copper Panels:

The Spany Copper panels have a copper thickness of 0.0197 inch (0.50 mm) and conform to ASTM B370. The panels are 16.14 inches (410 mm) wide by 52.56 inches (1335 mm) long, with an exposure of 14.57 inches (370 mm). The installed weight is approximately 1.35 psf (6.59 kg/m²). See [Figure 1](#) for a panel profile.

4.0 INSTALLATION

4.1 General:

Installation of Roser roofing panels must comply with this report, the manufacturer's published installation instructions, and the applicable code. The manufacturer's published installation instructions shall be available at the jobsite at all times during installation.

4.2 New Construction:

4.2.1 Support Conditions: The roofing panels must be installed on roofs having a slope of 3:12 (25%) or greater. Roof rafters must have a minimum specific gravity of 0.42 and shall be spaced not more than 24 inches (610 mm) on center. Roof panels must be installed over solid sheathing complying with the applicable code.

4.2.2 Underlayment: Underlayment must comply with 2018 IBC Section 1507.1.1 and IBC Section 1507.5.3 or 2018 and 2015 IRC Section R905.1.1 and IRC Section R905.4.3, as applicable.

4.2.3 Batten Installation: Battens must be nominally 2-by-2 lumber having a minimum specific gravity of 0.42 and a moisture content not exceeding 19 percent. Battens must be installed perpendicular to the rafters at 14⁵/₈ inches (370 mm) on center in accordance with the manufacturer's instructions. Battens must be fastened to each rafter with the fasteners specified in [Table 1](#) of this report.

4.2.4 Panel Installation: Upper panels must lap lower panels at the lower vertical face of each batten. The fasteners specified in [Table 1](#) must be installed through the two plies of panel into this face of the batten. See [Figures 4, 5](#) and [6](#) for typical installation details. Panel side laps must be approximately 2³/₈ inches (60 mm). Panel side laps in adjacent courses must be staggered a minimum of one pan or impression [approximately 7.5 inches (191 mm)].

Valley flashing must comply with IBC Section 1507.5.6 or IRC Section R905.4.6, as applicable. See [Figure 7](#). Roof openings must be flashed in accordance with IBC Section 1503.2 or IRC Section R903.2, as applicable. See [Figures 8](#) and [9](#). Openings through the roof for vents, etc., must be waterproofed and supported by additional blocking or roof framing as required by the code.

At gable edges, a continuous rake cap or barge cover of the same material as the panels, supplied by Roser, must be installed in accordance with the manufacturer's published installation instructions. See [Figure 10](#). At hips and ridges, panels must be cut, bent and installed, and hip and ridge caps of the same material as the panels, supplied by Roser, must be installed in accordance with the manufacturer's published installation instructions. See [Figures 2, 3](#) and [6](#).

4.3 Reroofing Applications:

Roser roofing panels must be installed over existing roofs in accordance with 2018 or 2015 IBC Section 1511, 2012, 2009 or 2006 IBC Section 1510, 2018 and 2015 IRC Section R908, or 2012, 2009 or 2006 IRC Section R907, as applicable.

4.3.1 Support Conditions: Roofing panels must be installed on roofs having a slope of 3:12 (25%) or greater. Roof rafters shall have a minimum specific gravity of 0.42 and must be spaced not more than 24 inches (610 mm) on center.

4.3.2 Counterbatten Installation: Counterbattens must be nominally 1-by-4 boards having a minimum specific gravity of 0.42 and a moisture content not exceeding 19 percent. Counterbattens must be installed over the existing roofing, parallel with and directly over the existing rafters. Counterbattens must be nailed at 12 inches (305 mm) on center with minimum 16d common nails having sufficient length to penetrate 1 inch (25.4 mm) into the rafter.

4.3.3 Batten Installation: Battens must be nominally 2-by-2 lumber having a minimum specific gravity of 0.42 and a moisture content not exceeding 19 percent. Battens must be installed perpendicular to the counterbattens and rafters at 14⁵/₈ inches (370 mm) on center per the manufacturer's instructions. Battens must be fastened to each rafter using fasteners with the minimum sizes as specified in [Table 1](#) of this report and having sufficient length to penetrate 1¹/₂ inches (38 mm) into the rafter.

4.3.4 Panel Installation: Panel installation must be the same as for new construction. See Section 4.2.4.

4.4 Allowable Negative Wind Pressures:

Roser roofing panels must be installed where the negative design wind pressure, determined in accordance with IBC Section 1609 or IRC Section R301.2.1, as applicable, does not exceed the allowable negative wind pressure specified in [Table 1](#) of this report.

4.5 Fire Classification:

When installed in accordance with this section and Sections 4.1 through 4.3, Roser steel and copper roofing panels are recognized as Class A or Class B roof assemblies in accordance with IBC Section 1505.2 and IRC Section R902.1.

4.5.1 Steel Panels: Spany, Roser Bond, Rowood, Cleo, Stonewood Shake and Piano roofing panels used as Class A roof coverings must be installed in accordance with this report and the manufacturer's installation instructions over minimum ¹⁵/₃₂-inch-thick (11.9 mm) plywood followed by one layer of GAF Corporation Versashield® Fire Resistant Roof Deck Protection ([ESR-2053](#)) followed by 2-by-2 wood battens.

4.5.2 Steel and Copper Panels: Spany, Roser Bond, Rowood, Cleo, Stonewood Shake and Piano roofing panels, used as Class B roof coverings, must be installed in accordance with the manufacturer's installation instructions over minimum ¹⁵/₃₂-inch-thick (11.9mm) plywood followed by 2-by-2 wood battens covered with one layer of Type G3 mineral surface cap sheet and 1-by-4 wood battens mechanically fastened to the 2-by-2 wood battens, with the metal panels mechanically fastened to the 1-by-4 wood battens.

5.0 CONDITIONS OF USE:

The Roser steel and copper roofing panels described in this report comply with, or are suitable alternatives to what is specified in, those codes listed in Section 1.0 of this report, subject to the following conditions:

- 5.1 The panels are manufactured, identified and installed in accordance with this report, the manufacturer's published installation instructions and the applicable code. In the event of a conflict between the installation instructions and this report, this report governs.
- 5.2 Use is limited to roofs with slopes of 3:12 (25%) or greater.
- 5.3 The panels are manufactured in Korea under a quality control program with inspections by ICC-ES.

6.0 EVIDENCE SUBMITTED

Data in accordance with the [ICC-ES Acceptance Criteria for Metal Roof Coverings \(AC166\)](#), dated October 2012 (editorially revised January 2018).

7.0 IDENTIFICATION

- 7.1 Each pallet of Roser roofing panels must be identified by a label with the manufacturer's name (Roser Co.); the product name; the plant location; the date of manufacture; and the evaluation report number (ESR-1763).
- 7.2 The report holder's contact information is the following:

ROSER CO., LTD.
400 NAE-RI, APRYANT-MYEON
GYEONGSAN, GYEONGBUK, 38539
KOREA
+82-53-817-5000
www.roser.com

TABLE 1—ALLOWABLE NEGATIVE WIND PRESSURES

PANEL TYPE	PANEL TO BATTEN FASTENERS ^{1,2}	BATTEN TO RAFTER FASTENERS ³	ALLOWABLE NEGATIVE WIND PRESSURE (PSF)
Spany Copper	5 - No. 8 x 1 1/2" long hex head screws	No. 10 x 3 1/2" long screw	60
Roser Bond, Cleo, Spany Steel, Rowood, Stonewood Shake, Piano	5 - No. 8 x 1 1/2" long hex head screws	No. 10 x 3 1/2" long screw	63
Roser Bond, Cleo, Spany Steel, Rowood, Stonewood Shake, Piano	5 - 8d nails	16d common nail	53

For SI: 1 inch = 25.4 mm, 1 lbf/ft² = 0.047 kPa.

¹Fasteners for stone-coated steel panels shall be galvanized steel.

²Fasteners for copper panels shall be 300 series stainless steel.

³Fastener sizes given are the minimums for application to new construction. Fasteners of battens to rafters through existing roofs must be of sufficient length to penetrate the rafter 1 1/2 inches (38 mm).

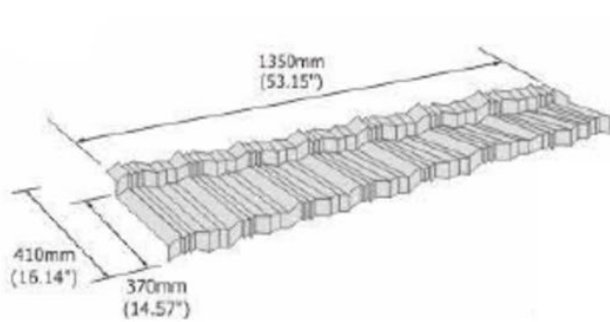

ROSER BOND AND CLEO

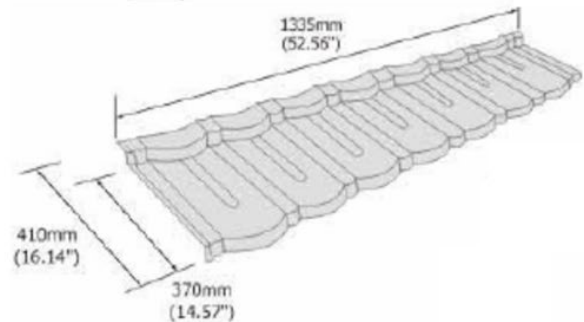

SPANY (STEEL & COPPER)

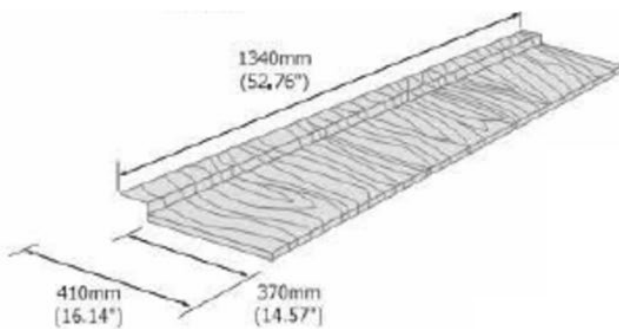

ROWOOD, STONEWOOD SHAKE

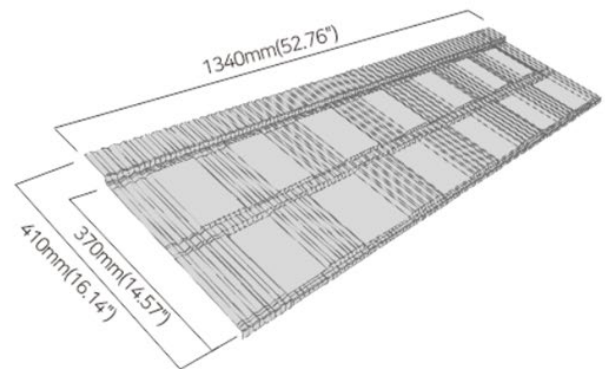

PIANO

FIGURE 1

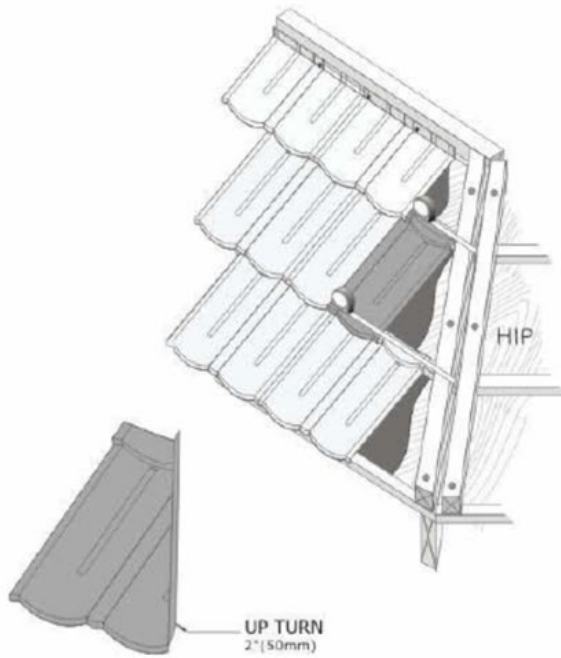

FIGURE 2

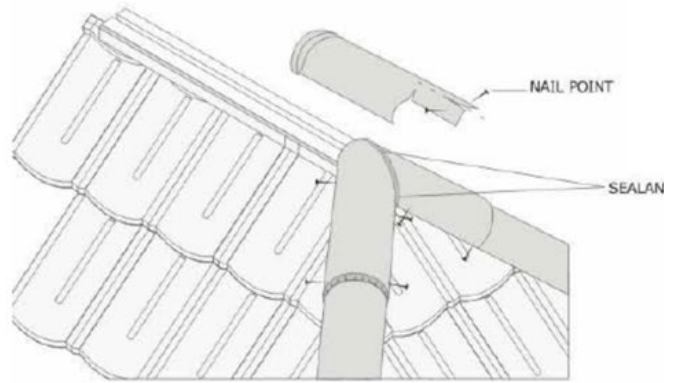

FIGURE 3

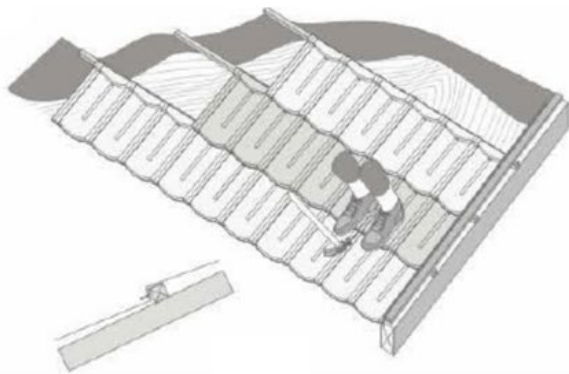

FIGURE 4

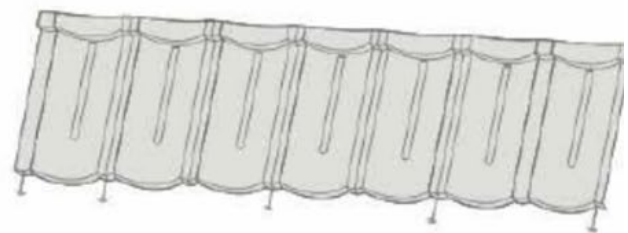

FIGURE 5

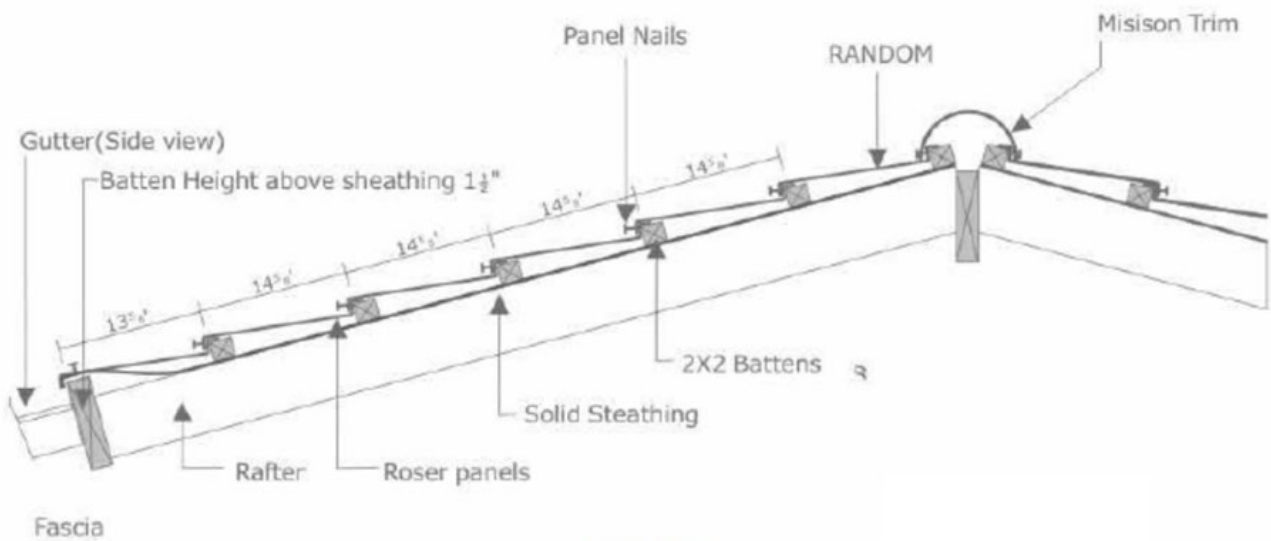

FIGURE 6

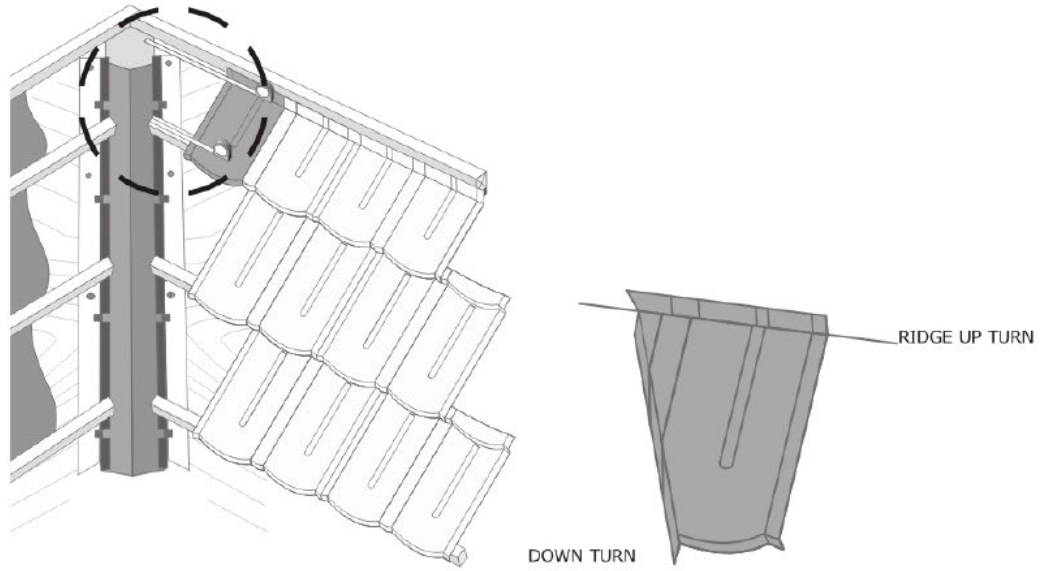

FIGURE 7

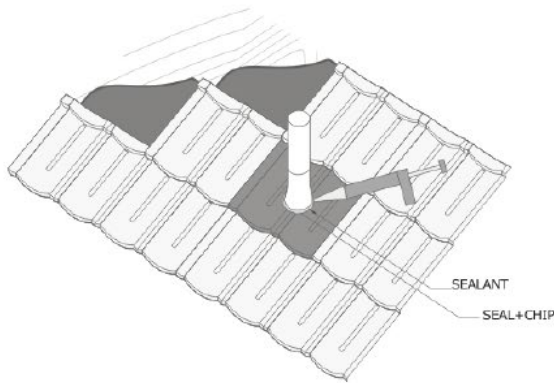

FIGURE 8

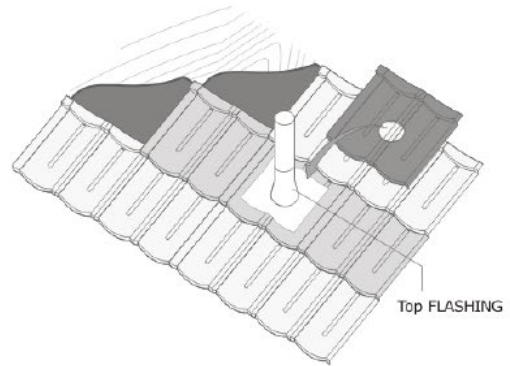

FIGURE 9

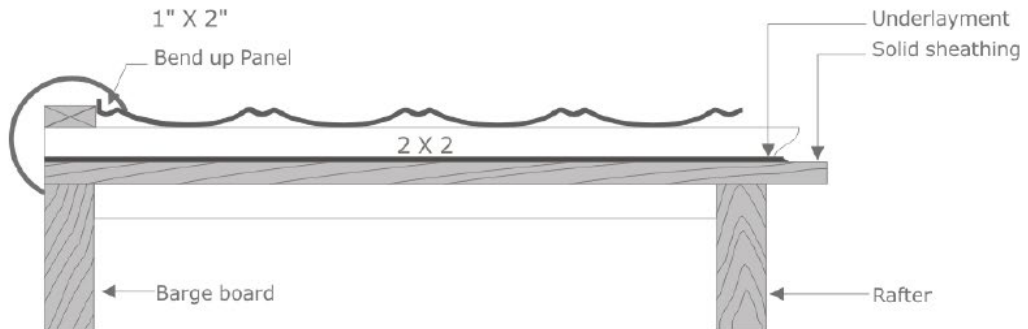

FIGURE 10