

ICC-ES Evaluation Report

ESR-1668

Reissued November 2023

This report also contains:

Revised March 2024

- CBC Supplement

Subject to renewal October 2024

- FBC Supplement

ICC-ES Evaluation Reports are not to be construed as representing aesthetics or any other attributes not specifically addressed, nor are they to be construed as an endorsement of the subject of the report or a recommendation for its use. There is no warranty by ICC Evaluation Service, LLC, express or implied, as to any finding or other matter in this report, or as to any product covered by the report.

Copyright © 2024 ICC Evaluation Service, LLC. All rights reserved.

<p>DIVISION: 07 00 00 — THERMAL AND MOISTURE PROTECTION</p> <p>Section: 07 46 46 — Fiber-Cement Siding</p>	<p>REPORT HOLDER: PLYCEM USA LLC</p>	<p>EVALUATION SUBJECT: ALLURA™ FIBER CEMENT LAP SIDING, VERTICAL PANEL SIDING, SOFFIT PANELS AND SHAPES SIDING</p>	
--	---	---	---

1.0 EVALUATION SCOPE

1.1 Compliance with the following codes:

- 2018, 2015, 2012, 2009 and 2006 [International Building Code® \(IBC\)](#)
- 2018, 2015 2012, 2009 and 2006 [International Residential Code® \(IRC\)](#)
- 2013 *Abu Dhabi International Building Code (ADIBC)*[†]

[†]The ADIBC is based on the 2009 IBC. 2009 IBC code sections referenced in this report are the same sections in the ADIBC.

Properties evaluated:

- Weather resistance
- Transverse loading
- Surface burning characteristics
- Non-combustibility
- Fire-resistive-rated construction

1.2 Evaluation to the following green code(s) and/or standards:

- 2022 [California Green Building Standards Code \(CALGreen\)](#), Title 24, Part 11
- 2020, 2015, 2012 and 2008 ICC 700 [National Green Building Standard™ \(ICC 700-2020, ICC 700-2015, ICC 700-2012 and ICC 700-2008\)](#)

Attributes verified:

See Section 3.0

2.0 USES

Plycem USA's Allura™ fiber cement lap and panel products are intended for use as exterior wall coverings and soffits.

3.0 DESCRIPTION

Allura™ products are autoclaved, single-faced wall coverings manufactured from a proprietary mixture of cellulose fiber, portland cement, silica, clay and limestone. See [Table 1](#) for dimensions and surface texture.

Design wind pressures must be determined in accordance with the applicable code. See [Table 2](#) for allowable wind pressures, fastener schedules, and installation requirements. Wind pressures noted in [Table 2](#) are allowable values for positive and negative directions.

Allura™ fiber cement sidings exhibit a flame-spread index of 25 or less and smoke-developed index of 450 or less when tested in accordance with ASTM E84.

Allura™ fiber cement is classified as non-combustible when tested in accordance with ASTM E136.

Allura™ lap and vertical panel siding products are recognized in this report as components of a one-hour, fire-resistance-rated, limited-load-bearing, wood-stud wall assembly, when installed in accordance with Section 4.7 of this report.

Lap siding, vertical panel siding, soffit panels and shapes siding come in lengths and widths as noted in [Table 1](#). All edges are square. Shapes siding is a panel-type product available with various designs.

The attributes of the stone veneer have been verified as conforming to the requirements of (i) CALGreen Section A4.405.1.3 for prefinished building materials and Section A5.406.1.2 for reduced maintenance; (ii) ICC 700-2020 Sections 601.7 and 11.601.7; (iii) ICC 700-2015 and ICC 700-2012 Sections 601.7, 11.601.7, and 12.1(A).601.7 for site-applied finishing materials; and (iv) ICC 700-2008 Section 601.7 for site-applied finishing materials.. Note that decisions on compliance for those areas rest with the user of this report. The user is advised of the project-specific provisions that may be contingent upon meeting specific conditions, and the verification of those conditions is outside the scope of this report. These codes or standards often provide supplemental information as guidance.

4.0 INSTALLATION

4.1 General:

The lap, vertical panel and shapes sidings must be installed over nominally 2-inch-thick wood framing members; minimum No. 20 gage [0.036 inch (0.91 mm)], 3.625-inch-by-1.375-inch (92 by 34.9 mm), 33 ksi steel, C-stud framing members; or minimum $\frac{7}{16}$ -inch structural wood sheathing as specified in [Table 2](#). A water-resistive barrier and sheathing must be installed behind the siding in accordance with the applicable code. Fasteners must be spaced no closer than $\frac{3}{4}$ inch (19.1 mm) from the panel horizontal edges, and must be no closer than $\frac{3}{8}$ inch (9.5 mm) from the panel vertical edges. Fasteners must be corrosion-resistant and sized as specified in [Table 2](#) of this report. Installation must comply with this report and the manufacturer's published application instructions.

Where nonstructural or nonfastener base structural sheathing is used under the siding, fastener length must be increased to provide a minimum $1\frac{1}{4}$ -inch (31.8 mm) penetration into the framing. Blind fastening is acceptable on lap siding installed according to the assemblies noted in [Table 2](#) and [Figure 2](#) of this report.

The installation of the Allura™ fiber cement sidings must be in accordance with the limitations described Section 1404.16 of the 2018 IBC and Section 1405.16 of the 2015, 2012 and 2009 IBC or Section 1405.15 of the 2006 IBC, as applicable, for all construction types.

4.2 Lap Siding:

Lap siding must be applied horizontally, commencing from the bottom of a wall, and with a minimum $1\frac{1}{4}$ -inch-wide (31.8 mm) overlap at the top of each board. Vertical joints between planks must be over studs and must be staggered on subsequent courses. If no wood stud or steel framing is available at the vertical joints, the siding vertical edges must be fastened to $\frac{7}{16}$ -inch structural sheathing. These vertical joints between planks must be lightly butted and must be covered with an H-section joint cover or located over a strip of flashing. Horizontal joints must be flashed with Z-flashing and blocked with solid wood framing. A $\frac{1}{8}$ -inch (3.2 mm) gap must be left at locations where the siding butts against door and window trim and at corners; such gaps must be flashed in accordance with the applicable code, then caulked. Trim and corners must be installed, and the siding must be finished in accordance with the manufacturer's application instructions. A clear distance of 6 inches (152 mm) must be maintained between the siding and the ground.

4.3 Vertical Panel Siding:

The vertical panel siding may be applied with the long dimension of the panel parallel or perpendicular to the framing. All panel edges must be backed by nominally 2-inch or thicker wood or minimum No. 20 gage [0.036 inch (0.91 mm)], 3.625-inch-by-1.375-inch (92 by 34.9 mm), 33 ksi steel C-stud framing members. Vertical joints must be lightly butted, must occur over framing members, and must be sealed with caulking or covered

with battens. Horizontal joints must be weatherproofed by leaving a $\frac{3}{8}$ -inch (9.5 mm) gap, which must be flashed with corrosion-resistant metal “Z” flashing and caulked. Where siding butts against door and window trim, and at corners, a $\frac{1}{8}$ -inch (3.2 mm) gap must be left and flashed in accordance with the applicable code and caulked. Trim and corners must be installed, and the siding must be finished in accordance with the manufacturer’s published application instructions. A clear distance of 6 inches (152 mm) must be maintained between the siding and the ground.

4.4 Soffit Panels:

The soffit panels must be attached to framing spaced a maximum of 24 inches (610 mm) on center, with the long dimension of the panel perpendicular to framing. Fasteners and fastener spacing must be as described for vertical siding in Section 4.3 and [Table 2](#). Fasteners must be stainless steel or hot-dipped galvanized, and fastener spacing must not exceed 6 inches (152 mm) on center.

4.5 Shapes Panels:

Shapes siding shall be installed in accordance with the manufacturer’s published application instructions.

4.6 Transverse Wind Pressures:

Allura™ fiber cement sidings must be attached to wall framing so that the allowable transverse wind load pressure (based on the siding size, framing spacing, and fastening schedule) noted in [Table 2](#) exceeds the design wind pressures determined in accordance with the applicable code.

4.7 One-hour Fire-resistance-rated Assembly:

The lap and vertical panel siding products noted in [Table 1](#) are recognized as components of one-hour, fire-resistance-rated, limited-load-bearing, wood-stud wall assemblies when constructed in accordance with [Figure 1](#) of this report. Wall design is limited to the allowable stress design approach, using the edition of the National Design Specification for Wood Construction (NDS) specified in the applicable code. The allowable axial load for a wall assembly constructed with lap siding must be determined in accordance with the applicable code.

5.0 CONDITIONS OF USE:

The Plycem USA Allura™ fiber cement products described in this report comply with, or are suitable alternatives to what is specified in, those codes listed in Section 1.0 of this report, subject to the following conditions:

- 5.1 The products must be installed in accordance with this report and the manufacturer’s instructions. In the event of a conflict, the instructions in this report must govern.
- 5.2 The products must be subject to the limitations described in Section 4.1 for all construction types.
- 5.3 Under the 2018 IBC Section 1402.5: and 2015 and 2012 IBC, Section 1403.5, installation on exterior walls, on buildings of Type I, II, III, and IV construction incorporating a combustible water-resistive barrier, is limited to buildings that are not greater than 40 feet in height above grade plane, except as permitted by Exception 2 of the 2018 IBC Section 1402.5 and 2015 IBC Section 1403.5.
- 5.4 The products have not been evaluated for in-plane racking resistance. Walls must be braced by other means as required by the applicable code.
- 5.5 The products are manufactured in Roaring River, North Carolina, and White City, Oregon, under a quality control program with inspections by ICC-ES.

6.0 EVIDENCE SUBMITTED

- 6.1 Data in accordance with [the ICC-ES Acceptance Criteria for Fiber Cement Panels Used as Exterior Wall Siding \(AC90\)](#), dated October 2018.
- 6.2 Reports of testing in accordance with ASTM E119, ASTM E136 and ASTM E84.

7.0 IDENTIFICATION

- 7.1 The lap siding, vertical panel siding, soffit panels, and shapes siding must bear a label noting the product name; the manufacturer’s name; the manufacturing plant location; and the evaluation report number (ESR-1668).
- 7.2 The report holder’s contact information is the following:

PLYCEM USA, LLC.
396 WEST GREEN ROAD SUITE 300
HOUSTON, TEXAS 77067
(281) 742-7076
www.allurausa.com

TABLE 1—DESCRIPTIONS OF ALLURA™ LAP SIDING, VERTICAL SIDING AND SOFFIT PANELS

PRODUCT TYPE		WIDTH	LENGTH	THICKNESS
Lap Siding	Smooth	5¼, 6¼, 7¼, 8¼, 9¼, 12 inches	12 feet	5/16 inch
	Cedar	5¼, 6¼, 7¼, 8¼, 9¼, 12 inches	12 feet	5/16 inch
	Smooth Beaded	7½ inches	12 feet	5/16 inch
	Textured Beaded	7½ inches	12 feet	5/16 inch
	Textured Dutch Lap	8¼ inches	12 feet	5/16 inch
Shapes Siding	Perfection Shingle	8¼ inches	12 feet	7/16 inch
	Random Square Straight Edge	12 inches (5" exposure)	48 inches	5/16 inch
	Random Square Straight Edge	16 inches (7" exposure)	48 inches	5/16 inch
	Random Square Staggered Edge	16 inches (7" exposure)	48 inches	5/16 inch
	Half Rounds	16 inches (7" exposure)	48 inches	5/16 inch
	Octagons	16 inches (7" exposure)	48 inches	5/16 inch
	Individual Shakes	6¼, 8¼, 12 inches	16 inches	¼ inch
Vertical Siding	Stucco	4 feet	8, 9, 10 feet	5/16 inch
	Cedar 8" Groove	4 feet	8, 9, 10 feet	5/16 inch
	Cedar No Groove	4 feet	8, 9, 10 feet	5/16 inch
	Smooth	4 feet	8, 9, 10 feet	5/16 inch
Soffit Panels	Cedar	12, 16, 24 inches	12 feet	¼ inch
	Cedar Ventilated	12, 16, 24 inches	12 feet	¼ inch
	Smooth	12, 16, 24 inches	12 feet	¼ inch
	Smooth Ventilated	12, 16, 24 inches	12 feet	¼ inch
	Porch Panel	4 feet	8 feet	¼ inch

For SI: 1 inch = 25.4 mm; 1 foot = 304.8 mm.

TABLE 2—ALLOWABLE WIND PRESSURES AND REQUIRED FASTENER SCHEDULE
IBC SECTION 1609, ASCE 7; MAX. WALL HEIGHT (H) ≤30 FT., CATEGORY II, ENCLOSED BUILDINGS, ZONE 5 (CRITICAL)
 (Continued)

PRODUCT	PRODUCT DIMENSION (in.)	FASTENER TYPE	FASTENING METHOD ¹	FRAMING TYPE	FRAMING SPACING (in)	Allowable Pressure (psf)	Basic Wind Speed V _{ult} (V _{asd}) in mph, IBC Figure 1609.3.1														
							100 (78)	110 (85)	120 (93)	130 (101)	140 (108)	150 (116)	160 (124)	170 (132)	180 (139)	190 (147)	Exposure				
Individual Shakes	18" (8" Reveal)	Roofing Nails 1 1/2" long x 0.120 shank x 0.375" head dia.	Per Instructions	2x4 SPF w/ 7/16" OSB ²	24	31.3	OK	OK	OK	OK	OK							B			
							OK	OK	OK									C			
							OK	OK											D		
Individual Shakes	18" (8" Reveal)	6d Siding Nails 2" long x 0.095" shank x 0.235" head dia.	Per Instructions	2x4 SPF w/ 7/16" OSB ²	24	27.1	OK	OK	OK	OK								B			
							OK	OK											C		
							OK													D	
Shapes	15.75" (7" Reveal)	6d Ring-shank Nails 1 1/2" x 0.095" shank x 0.235" head dia.	Per Instructions	2x4 SPF w/ 7/16" OSB ²	16	34.3	OK	OK	OK	OK	OK	OK							B		
							OK	OK	OK	OK											C
							OK	OK	OK												
Shapes	15.75" (7" Reveal)	Ring-Shank Roofing Nails 1 1/2" long x 0.120 shank x 0.375" head dia.	Per Instructions	2x4 SPF w/ 7/16" OSB ²	16	22.7	OK	OK	OK										B		
							OK														C
Shapes	15.75" (7" Reveal)	6d Siding Nails 2" long x 0.095" shank x 0.235" head dia.	Into Studs	2x4 SPF	16	21.3	OK	OK	OK										B		
							OK														C
Shapes	15.75" (7" Reveal)	No.9x 1 5/8" long x 0.375" head dia. ribbed waferhead screws	Per Instructions	Min. 20 ga., 3.625" x 1.375" Metal C-stud w/ 7/16" OSB	16	33.3	OK	OK	OK	OK	OK	OK							B		
							OK	OK	OK												C
							OK	OK													

For SI: 1 inch = 25.4mm, 1 pound/foot² = 47.8803 kPa: 1 pound = 4.448N.

¹ See Figure 2 of this report for a description of face and blind nailing.

² For these assemblies the walls must be solidly sheathed with minimum 7/16-inch OSB structural wood panels complying with DOC PS-2 and installed with 8d nails spaced a maximum of 4-inches o.c. on the edges and a maximum of 8-inches o.c. in the field.

³Smooth-shank stainless steel nails are outside scope of this report.

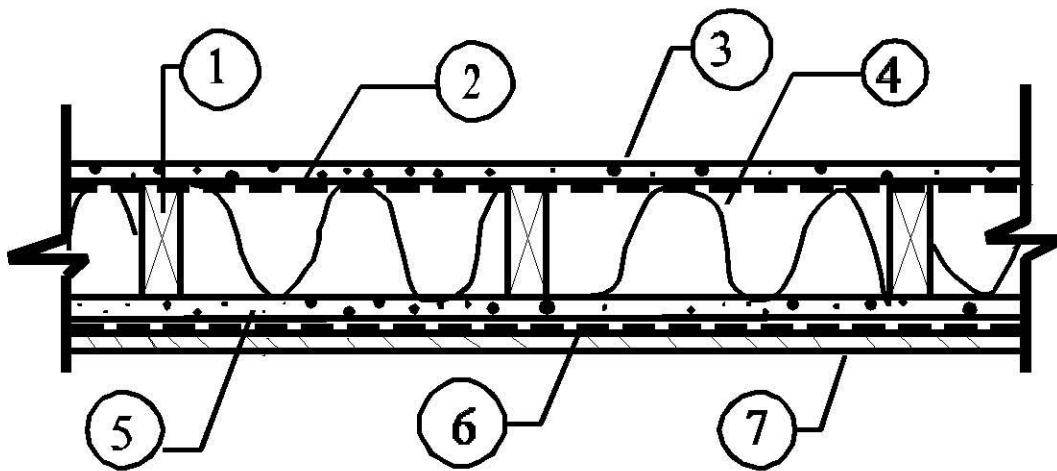

- ITEM 1:** Allowable axial load for a wall assembly constructed with Allura™ fiber cement Lap Siding and for a wall assembly constructed with Allura™ fiber cement Vertical Siding must be determined in accordance with the applicable code.
- ITEM 2:** Continuous vapor barrier in accordance with the applicable code and the manufacturer's instructions.
- ITEM 3:** Interior side of wall assembly must be covered with $\frac{5}{8}$ -inch-thick ASTM C36-95b or ASTM C1396 Type X gypsum wall board. Wall board must be fastened to wood framing with $1\frac{5}{8}$ -inch-long No. 6 Type W drywall screws spaced 8 inches on center at the edges and 12 inches in center in the field. All screw heads must be covered with joint compound and all wallboard joints must be covered with joint compound and taped and treated with joint compound. Joint compound must comply with ASTM C474 and C475.
- ITEM 4:** Insulation must be provided and must be either mineral wool or fiberglass. Mineral wool must have a nominal density of 2.5 lbs/ft³. The fiberglass must be R13. Batts must be 16 inches wide.
- ITEM 5:** Exterior side of wall assembly must be covered with $\frac{5}{8}$ -inch-thick ASTM C79-95 or ASTM C1396 Type X gypsum sheathing. Gypsum sheathing must be fastened to wood framing with $1\frac{5}{8}$ -inch-long No. 6 Type S drywall screws spaced 8 inches on center at the edges and 12 inches on center in the field.
- ITEM 6:** Weather-resistive barrier in accordance with this report and the applicable code.
- ITEM 7:** Exterior wall covering must be either Allura™ fiber cement Lap Siding or Allura™ fiber cement Vertical Siding. Where Lap siding is utilized the overlap must be a minimum of $1\frac{1}{4}$ inches and face fastened with $2\frac{1}{2}$ -inch-long double hot-dipped galvanized roofing fasteners with a head diameter per [Table 2](#). The fastening schedule for Allura™ Fiber Cement Vertical Siding must be a maximum of 6 inches o.c. at the edges and 12 inches o.c. in the field with 8d common nails.

For SI: 1 inch = 25.4 mm; 1 lbf = 4.448 N.

**FIGURE 1—ONE-HOUR FIRE-RESISTANCE-RATED WALL ASSEMBLY
FOR ALLURA™ FIBER CEMENT LAP AND VERTICAL SIDING**

face nail option

blind nail option

1 1/4" overlap minimum

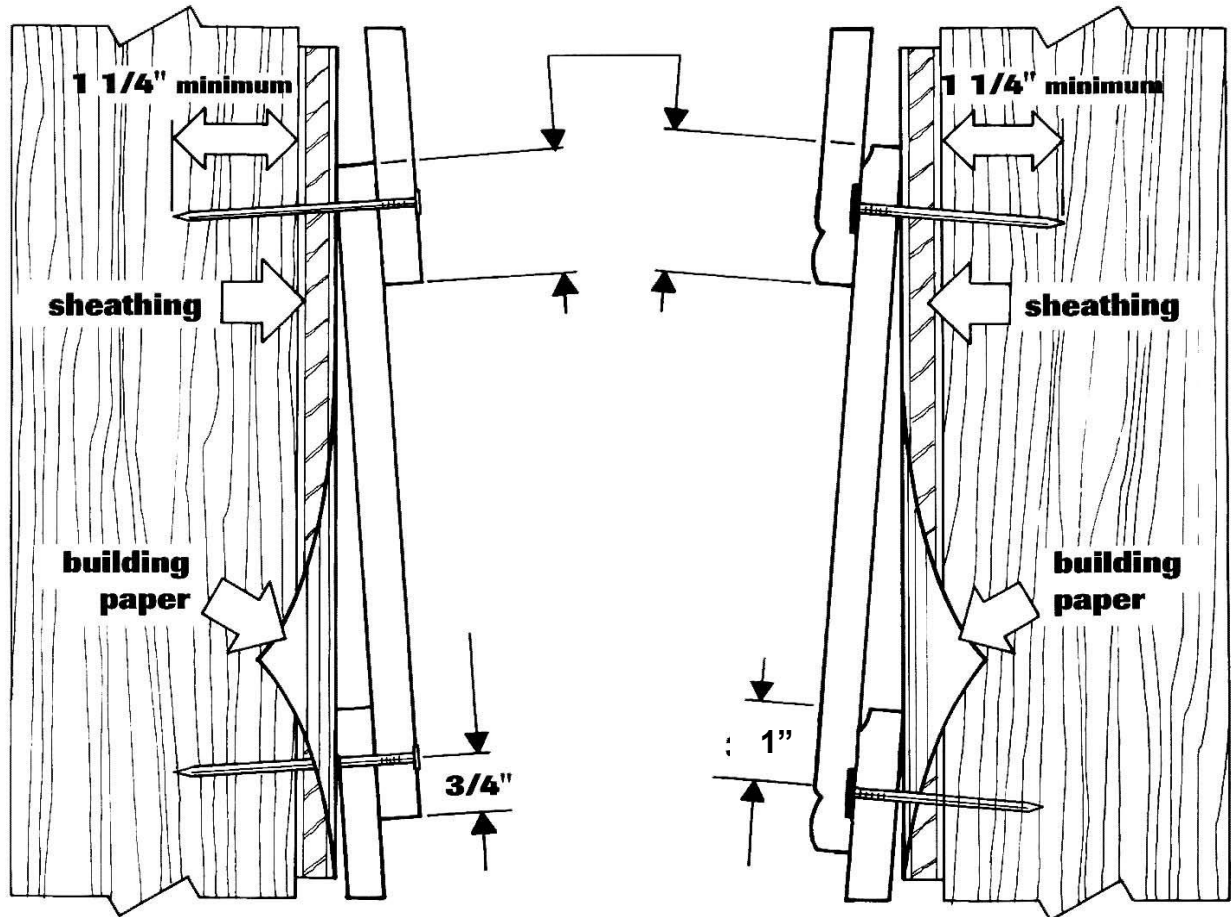

NOTES:

¹See Section 4 and Table 2 of this report for the fastening requirements of lap siding.

²For SI: 1 inch = 25.4 mm.

FIGURE 2—ALLURA™ FIBER CEMENT LAP SIDING INSTALLATION DIAGRAMS

DIVISION: 07 00 00—THERMAL AND MOSITURE PROTECTION
Section: 07 46 46—Fiber Cement Siding

REPORT HOLDER:

PLYCEM USA LLC

EVALUATION SUBJECT:

ALLURA™ FIBER CEMENT LAP SIDING, VERTICAL PANEL SIDING, SOFFIT PANELS AND SHAPES SIDING

1.0 REPORT PURPOSE AND SCOPE**Purpose:**

The purpose of this evaluation report supplement is to indicate that Allura™ fiber cement lap siding, vertical panel siding, soffit panels and shapes siding, described in ICC-ES evaluation report ESR-1668, have also been evaluated for compliance with the codes noted below.

Applicable code editions:

- 2019 *California Building Code*® (CBC)

For evaluation of applicable chapters adopted by the California Office of Statewide Health Planning and Development (OSHPD) AKA: California Department of Health Care Access and Information (HCAI) and the Division of State Architect (DSA), see Sections 2.1.1 and 2.1.2 below.

- 2019 *California Residential Code*® (CRC)

2.0 CONCLUSIONS**2.1 CBC:**

The Allura™ fiber cement lap siding, vertical panel siding, soffit panels and shapes siding, described in Sections 2.0 through 7.0 of the evaluation report ESR-1668, complies with CBC Chapters 7 and 14 provided the design and installation are in accordance with the 2018 *International Building Code*® (IBC) provisions noted in the evaluation report and the additional requirements of Chapter 14 Section 1404.3 as applicable.

2.1.1 OSHPD:

The applicable OSHPD Sections of the CBC are beyond the scope of this supplement.

2.1.2 DSA:

The applicable DSA Sections of the CBC are beyond the scope of this supplement.

2.2 CRC:

The Allura™ fiber cement lap siding, vertical panel siding, soffit panels and shapes siding, described in Sections 2.0 through 7.0 of the evaluation report ESR-1668, complies with CRC Chapters R3 and R7, provided the design and installation are in accordance with the 2018 *International Residential Code*® (IRC) provisions noted in the evaluation report and the additional requirements in CRC Section R702.7

This supplement expires concurrently with the evaluation report, reissued November 2023 and revised March 2024.

DIVISION: 07 00 00—THERMAL AND MOISTURE PROTECTION
Section: 07 46 46—Fiber-Cement Siding

REPORT HOLDER:

PLYCEM USA LLC

EVALUATION SUBJECT:

ALLURA™ FIBER CEMENT LAP SIDING, VERTICAL PANEL SIDING, SOFFIT PANELS AND SHAPES SIDING

1.0 REPORT PURPOSE AND SCOPE**Purpose:**

The purpose of this evaluation report supplement is to indicate that Allura™ Fiber Cement lap siding, vertical panel siding, soffit panels and shapes siding, described in ICC-ES evaluation report ESR-1668, have also been evaluated for compliance with the codes noted below.

Applicable code editions:

- 2020 and 2017 *Florida Building Code—Building*
- 2020 and 2017 *Florida Building Code—Residential*

2.0 CONCLUSIONS

The Allura™ products, described in Sections 2.0 through 7.0 of ICC-ES evaluation report ESR-1668, comply with the *Florida Building Code—Building* and the *Florida Building Code—Residential*, provided the design requirements are determined in accordance with the *Florida Building Code—Building* or the *Florida Building Code—Residential*, as applicable. The installation requirements noted in ICC-ES evaluation report ESR-1668 for the 2018 and 2015 *International Building Code*® meet the requirements of the *Florida Building Code—Building* or the *Florida Building Code—Residential*, as applicable, with following conditions.

- Design wind loads must be based on Section 1609 of the *Florida Building Code—Building* or Section 301.2.1.1 of the *Florida Building Code—Residential*, as applicable.
- Load combinations must be in accordance with Section 1605.2 or Section 1605.3 of the *Florida Building Code—Building*, as applicable.
- Siding attachment must meet the requirements of Section R703.4 of the *Florida Building Code—Residential*, where applicable.

Use of the Allura™ products for compliance with the High-Velocity Hurricane Zone provisions of the *Florida Building Code—Building* and the *Florida Building Code—Residential* have not been evaluated, and is outside the scope of this supplemental report.

For products falling under Florida Rule 61G20-3, verification that the report holder's quality assurance program is audited by a quality assurance entity approved by the Florida Building Commission for the type of inspections being conducted is the responsibility of an approved validation entity (or the code official when the report holder does not possess an approval by the Commission).

This supplement expires concurrently with the evaluation report, reissued November 2023 and revised March 2024.