

# ICC-ES Evaluation Report

ESR-1471

Reissued September 2023

This report also contains:

- CBC Supplement

Subject to renewal September 2024

ICC-ES Evaluation Reports are not to be construed as representing aesthetics or any other attributes not specifically addressed, nor are they to be construed as an endorsement of the subject of the report or a recommendation for its use. There is no warranty by ICC Evaluation Service, LLC, express or implied, as to any finding or other matter in this report, or as to any product covered by the report.

Copyright © 2023 ICC Evaluation Service, LLC. All rights reserved.

<p><b>DIVISION: 09 00 00 - FINISHES</b></p> <p><b>Section: 09 24 00 – Section Name: Portland Cement Plastering</b></p>	<p><b>REPORT HOLDER: ULTRAKOTE PRODUCTS, LLC</b></p>	<p><b>EVALUATION SUBJECT: ULTRAKOTE PRODUCTS, LLC</b></p>	
--	--	---	---

## 1.0 EVALUATION SCOPE

### Compliance with the following codes:

- 2021, 2018, 2015, 2012, 2009 and 2006 [International Building Code® \(IBC\)](#)
- 2021, 2018, 2015, 2012, 2009 and 2006 [International Building Code® \(IBC\)](#)
- 1997 *Uniform Building Code™* (UBC)

### Properties evaluated:

- Structural
- Durability
- Fire-resistance-rated construction
- Types I through IV (noncombustible) construction

## 2.0 USES

The Ultrakote One-Kote Stucco System is an alternative exterior wall covering to that specified in IBC Chapter 25, IRC Section R703 and UBC Chapter 25 and may be installed in any type of construction (Types I, II, III, IV or V). The systems may be used to construct one-hour fire-resistance-rated wall assemblies when installed in accordance with Section 4.4 of this report and walls that are required to be used in noncombustible (Types I, II, III and IV) construction, when installed in accordance with Section 4.5 of this report.

## 3.0 DESCRIPTION

### 3.1 General:

The Ultrakote One-Kote Stucco System is a proprietary mixture of portland cement, sand, glass fibers and proprietary ingredients reinforced with wire fabric or metal lath and applied to substrates of expanded polystyrene (EPS) insulation board, gypsum sheathing, fiberboard, plywood or oriented strand board (OSB). The system is installed on exterior walls of wood or steel stud construction. Ultrakote is also applied over concrete or unit masonry units with or without lath.

### 3.2 Materials:

**3.2.1 Ultrakote One-Kote Stucco Concentrate:** The Ultrakote One-Kote Stucco Concentrate mixture is packaged in 80-pound (36.3 kg) bags. Four-and-one-half gallons (17 L) to 6 gallons (22.7 L) of water and 240 pounds (108.9 kg) of sand are added to each bag in the field and mixed in accordance with the manufacturer’s

recommendations. Alternatively, the mixture may be blended at a batching plant and delivered with sand in a bulk-mixer to the jobsite and field-mixed with water, under the following conditions:

- a. The bulk-mixer bears an identification label bearing the UltraKote, Inc., name and address, batch plant name and address, product name, and evaluation report number (ESR-1471).
- b. A signed certificate from the batching plant accompanies each batch specifying the plant name, contractor's name, jobsite address, date, materials batched, quantity, and curing instructions. The ratio of batched amounts must be 240 pounds (108.9 kg) of sand to 80 pounds (36.3 kg) of mixture.
- c. Procedures are in place to prevent tampering in controlling the amount of mixture and sand combined.

Approved color pigments may be added to the stucco mix in accordance with the manufacturer's instructions.

**3.2.2 Ultrakote One-Kote Stucco Premix:** A factory-prepared mixture of sand and One-Kote Stucco Concentrate, packaged in 80-pound (36.3 kg) bags. 1.1 gallons (4.2 L) to 1.5 gallons (5.7 L) of water are added to each bag in the field and mixed.

**3.2.3 Sand:** The sand must be clean and free from deleterious amounts of loam, clay, silt, soluble salts and organic matter. Sampling and testing shall comply with ASTM C144 or C897. Sand shall be graded in accordance with ASTM C144 or C897 within the following limits:

RETAINED ON U.S. STANDARD SIEVE	PERCENT RETAINED BY WEIGHT ± 2 PERCENT	
	Minimum	Maximum
No. 4 (4.75 mm)	—	0
No. 8 (2.36 mm)	0	10
No. 16 (1.18 mm)	10	40
No. 30 (600 m)	30	65
No. 50 (300 mm)	70	90
No. 100 (150 mm)	95	100

**3.2.4 Insulation Board:** Expanded polystyrene (EPS) insulation board must have a maximum nominal density of 1.5 pounds per cubic foot, a flame-spread index of 25 or less and a smoke-developed index of 450 or less when tested in accordance with ASTM E84 or UBC Standard 8-1, and must comply with ASTM C578 as Type II. All boards must have recognition in a current evaluation report issued by ICC-ES. See Section 7.0 of this report for board identification.

Boards installed without sheathing, over open framing, must have a thickness from 1 to 1½ inches (25.4 mm to 38 mm) and have ¾-inch-high (9.5 mm) tongues with compatible grooves for horizontal joints. See [Figure 1](#) for joint detail.

When installed over wood-based sheathing as part of a water-resistive barrier, as described in Section 3.2.9.1, the boards are permitted to be 1 inch thick (25.4 mm) with tongue-and-groove horizontal edges as detailed in [Figure 1](#).

When installed over gypsum sheathing, as described in Section 4.3.3, the boards must have a minimum thickness of ½-inch (12.7 mm) and a minimum density of 1 pcf (16 kg/m³).

When boards are used over solid sheathing with a code-complying water-resistive barrier, the boards must have ¼-inch-wide-by-⅛-inch-deep (6.4 by 3.2 mm) grooves spaced 12 inches (305 mm) on center on the back face of the boards.

**3.2.5 Lath:**

**3.2.5.1 Wire Fabric Lath:** Wire fabric lath must comply with the ICC-ES Acceptance Criteria for Metal Plaster Bases (Lath) (AC191) and be recognized in a current ICC-ES evaluation report for use with cementitious exterior wall coverings. Minimum No. 20 gage [0.035 inch (0.89 mm)], 1-inch galvanized steel, woven-wire fabric must be used. Lath must be furred when applied over all substrates except unbacked polystyrene board. Furring must comply with the following requirements:

- 1. When maximum total coating thickness is ½ inch (12.7 mm) or less, the body of the lath must be furred a minimum of ⅛ inch (3.2 mm) from the substrate after installation.

2. When total coating thickness is greater than  $\frac{1}{2}$  inch (12.7 mm), No. 17 gage [0.058 inch (1.47 mm)] by  $1\frac{1}{2}$ -inch (38 mm) woven-wire fabric lath must be used. The body of the lath must be furred a minimum of  $\frac{1}{4}$  inch (6.4 mm) from the substrate after installation.

**3.2.5.2 Metal Lath:** Metal lath must comply with AC191 and IBC Table 2507.2, IRC Section R703.6 or UBC Table 25-B, as applicable. Furring and self-furring requirements are as set forth in Section 3.2.5.1 for wire fabric lath.

**3.2.6 Fiberboard:** Fiberboard must be minimum  $\frac{1}{2}$ -inch-thick (12.7 mm) asphalt-impregnated fiberboard complying with ASTM C208, Type IV, Grade 1, wall sheathing in accordance with the 2021, 2018 or 2015 IBC Section 2303.1.6 (2012, 2009 and 2006 IBC Section 2303.1.5).

**3.2.7 Wood Structural Panel Sheathing:** Wood structural panel sheathing must be minimum  $\frac{5}{16}$ -inch-thick (7.9 mm) plywood or OSB for studs spaced 16 inches (406 mm) on center, and minimum  $\frac{3}{8}$ -inch-thick (9.5 mm) plywood or  $\frac{7}{16}$ -inch-thick (11.1 mm) OSB for studs spaced 24 inches (610 mm) on center. Plywood must comply with U.S. Department of Commerce Product Standard PS-1 (UBC Standard 23-2) as exterior-grade or Exposure 1. Oriented strand board (OSB) must be Exposure 1 and comply with U.S. Department of Commerce Product Standard PS-2 (UBC Standard 23-3).

**3.2.8 Gypsum Board:** Water-resistance treated core gypsum sheathing must comply with ASTM C79 or ASTM C1396. Gypsum wallboard must comply with ASTM C36 or ASTM C1396.

**3.2.9 Backerboard:** The backerboard must be water-resistant gypsum backerboard complying with ASTM C630.

**3.2.10 Veneer Base:** The veneer base must be gypsum veneer base complying with ASTM C588.

### 3.2.11 Weather Protection:

**3.2.11.1 Water-resistive Barrier:** A water-resistive barrier is required and must comply with 2021 and 2018 IBC Section 1403.2 (2015, 2012, 2009 and 2006 IBC Section 1404.2), IRC Section R703.2 or UBC Section 1404.1, as applicable. Minimum No. 15 asphalt nonperforated felt, complying as Type I in accordance with ASTM D226 (IBC or IRC); minimum Grade D kraft building paper complying with UBC Standard 14-1; asphalt-saturated rag felt complying with UL55A (UBC); or material recognized in a current ICC-ES evaluation report as complying with the ICC-ES Acceptance Criteria for Water-resistive Barriers (AC38), is required.

When the Ultrakote One-Kote Stucco System is applied over any wood-based sheathing, the barrier must be one of the following:

- A minimum of two layers of a water-resistive barrier complying with ASTM E2556, Type I as set forth in 2021, 2018 or 2015 IBC Section 2510.6 (Grade D kraft building paper as set forth in the 2012, 2009 and 2006 IBC Section 2510.6), 2021, 2018 or 2015 IRC Section R703.7.3 and 2012, 2009 and 2006 IRC Section R703.6.3 or UBC Section 2506.4, or an equivalent recognized in a current ICC-ES evaluation report.
- One layer of insulation board, having horizontal tongue-and-groove edges, as described in Section 3.2.4 of this report, over one layer of Grade D kraft building paper having a minimum water-resistance rating of 60 minutes; or an equivalent recognized in a current ICC-ES evaluation report.

Application of the barrier must comply with 2021 and 2018 IBC Section 1403.3 (2015, 2012 and 2009 IBC Section 1404.3, IRC Section R703.2 or UBC Section 1402.1, as applicable).

When Tyvek StuccoWrap, recognized in [ESR-2375](#), is used as the water-resistive barrier, the grooved insulation board described in Section 3.2.4 is not required. The Tyvek StuccoWrap must be installed as described in [ESR-2375](#).

**3.2.11.2 Vapor Retarder:** Protection against condensation must be provided in accordance with the 2021 and 2018 IBC Section 1404.3 (2015, 2012 and 2009 IBC Section 1405.3 or 2006 IBC Section 1403.2), as applicable. Under the 2021, 2018, 2015 and 2012 IRC, a vapor retarder must be provided in accordance with IRC Section R702.7, unless its omission is permitted under the exceptions in IRC Section R702.7. Under the 2009 IRC, a vapor retarder must be provided in accordance with IRC Section R601.3, unless its omission is permitted under the exceptions in IRC Section R601.3. Under the 2006 IRC, a vapor retarder must be provided in accordance with IRC Section R318.1, unless its omission is permitted under the exceptions in IRC Section R318.1.

**3.2.11.3 Flashing:** Flashing complying with the 2021 and 2018 IBC Section 1404.4 (2015, 2012 and 2009 IBC Section 1405.4, 2006 IBC Section 1405.3), 2021, 2018 or 2015 IRC Section R703.4, or 2012, 2009 and 2006 IRC Section R703.8 or UBC Section 1404.2, as applicable, must be provided. Where membrane flashing is used, it must be a self-adhering, flexible rubberized asphalt and polyethylene material complying with the

ICC-ES Acceptance Criteria for Flexible Flashing Materials (AC148), and must be shingle-lapped with the water-resistive barrier. Rigid flashing must be sloped towards the exterior, with upturned legs on the interior side at the ends. Flashing must extend beyond the surface of the exterior wall.

**3.2.12 Caulking:** Acrylic latex sealant material must comply with ASTM C834.

**3.2.13 Miscellaneous:** All trim, screeds and corner reinforcement must be galvanized steel or approved plastic.

## 4.0 INSTALLATION

### 4.1 General:

The exterior cementitious coating is applied by hand-troweling or machine-spraying in one or two coats to a minimum  $\frac{3}{8}$ -inch (9.5 mm) thickness. The lath must be embedded in the minimum coating thickness and therefore cannot be exposed. The finish coat, if used, must be applied within 72 hours after the base coat unless the latter is sprayed/brushed with an acrylic-bonding adhesive, or a bonding treatment is added to the finish-coat stucco mix prior to application. Flashing, corner reinforcement, metal trim and weep screeds must be installed as shown in [Figure 3](#). The coating is applied at ambient air temperatures ranging from 40°F (4.4°C) to 120°F (49°C) by applicators approved by Ultrakote, Inc. After application, the coating must be protected from freezing air temperatures during the initial six hours of curing. An installation card, as noted in [Figure 2](#), must be on the jobsite with the name of the applicator and the product to be used before any water-resistive barrier or exterior sheathing is installed. Also, see Section 5.6 of this report.

### 4.2 Application over Open Framing:

The water-resistive barrier must be placed, as set forth in Section 3.2.9, over open framing spaced a maximum of 24 inches (610 mm) on center. The insulation board described in Section 3.2.4, must be placed horizontally with tongues faced upward, and shall be temporarily held in place with galvanized staples or roofing nails. Vertical butt joints must be staggered a minimum of one stud space from adjacent courses and occur directly over studs. The lath must be applied tightly, with  $1\frac{1}{2}$ -inch (38 mm) end and side laps, over the insulation board and fastened through the insulation board and water-resistive barrier, to wood studs, sills and plates having a minimum specific gravity of 0.50, at 6 inches (152 mm) on center using No. 11 gage galvanized roofing nails having  $\frac{7}{16}$ -inch-diameter (11.1 mm) heads, or No. 15 gage galvanized staples having a minimum crown width of  $\frac{1}{2}$  inch (12.7 mm). Minimum fastener penetration must be 1 inch (25.4 mm) into wood framing. Care shall be taken to avoid overdriving fasteners.

Wall bracing in accordance with the 2021, 2018 or 2015 IBC Section 2308.6, 2012, 2009 and 2006 IBC Section 2308.9.3 or 2308.12, IRC Section R602.10 or UBC Sections 2320.11.3 and 2320.11.4, as applicable, is required. Outside wall corners and parapet corners must be covered with extra metal corner reinforcements attached to the framing members with approved fasteners spaced 18 inches (457 mm) on center, or as necessary to hold plumb. Weep screeds must comply with, and be installed at the bottom of the wall in accordance with, IBC Section 2512.1.2, 2021, 2018 and 2015 IRC Section R703.7.2.1, or 2012, 2009 and 2006 IRC Section R703.6.2.1 or UBC Section 2506.5, as applicable. Galvanized steel,  $1\frac{3}{8}$ -inch (35 mm), No. 22 gage [0.025 inch (0.635 mm)], J-shaped trim pieces must be installed at other areas where insulation board is exposed. See [Figure 3](#) for typical installation details. At windows and doors, flashing must be installed in accordance with the 2021 and 2018 IBC Section 1404.4 (2015, 2012, and 2009 IBC Section 1405.4, 2006 IBC Section 1405.3), 2021, 2018 or 2015 IRC Section R703.4, or 2012, 2009 and 2006 IRC Section R703.8 or UBC Section 1402.2, as applicable. Holes for hose bibbs, electrical panels and other penetrations of substrate surfaces, except those caused by fasteners, must also be caulked. The coating must be then applied as described in Section 4.1.

The Ultrakote stucco system may also be applied to minimum No. 20 gage [0.035 inch (0.89 mm) minimum] steel studs spaced a maximum of 24 inches (610 mm) on center. The lath is applied tightly over the EPS board with  $1\frac{1}{2}$ -inch (38 mm) end and side laps and fastened through the board and water-resistive barrier to the metal studs with No. 7, S12-20, self-drilling, self-tapping, panhead screws spaced 6 inches (152 mm) on center. Screw-head diameter is a minimum of 0.333 inch (8.5 mm). The screws must be long enough to penetrate the studs  $\frac{1}{4}$  inch (6.4 mm) with a  $1\frac{1}{4}$ -inch (32 mm) minimum length.

### 4.3 Application over Solid Backing:

**4.3.1 Fiberboard:** Minimum  $\frac{1}{2}$ -inch-thick (12.7 mm) fiberboard sheathing must be installed directly over wood studs or minimum No. 20 gage (0.035 inch [0.889 mm] thick) steel studs spaced a maximum of 24 inches (610 mm) on center. The fiberboard must be temporarily held in place with corrosion-resistant staples or roofing nails for wood studs, or self-drilling tapping screws for steel studs. A water-resistive barrier, as set forth in Section 3.2.9, must be applied over the fiberboard prior to application of the lath or optional insulation board.

When the optional insulation board is used, the boards must have grooves as described in Section 3.2.4, or flat-faced insulation boards may be used, provided the water-resistive barrier is Tyvek StuccoWrap as described in Section 3.2.9. When grooved insulation boards are used, they must be aligned vertically, but may be offset a maximum of 6 inches (152 mm) from adjacent boards. The vertical joints of insulation boards are not required to align with the framing. The lath must be attached to studs through the sheathing with fasteners and spacing described for insulation board in Section 4.2 of this report; or as described for fiberboard in the 2021, 2018 or 2015 IBC Table 2304.10.1, 2012, 2009 and 2006 IBC Table 2304.9.1, IRC Table R602.3 (1) or UBC Table 23-II-B-1, as applicable; whichever is more restrictive.

Wall bracing in accordance with the 2021, 2018 or 2015 IBC Section 2308.6, 2012, 2009 and 2006 IBC Section 2308.9.3, IRC Section R602.10 or UBC Sections 2320.11.3 and 2320.11.4, as applicable, or an acceptable alternate, must be required. Outside wall corners and parapet corners must be covered with extra metal corner reinforcements attached to the framing members with approved fasteners spaced 18 inches (457 mm) on center, or as necessary to hold plumb (see [Figure 3](#)). For wall corners, metal reinforcement is optional when construction is in accordance with [Figure 3](#). Weep screeds must comply with, and be installed at the bottom of the wall in accordance with, IBC Section 2512.1.2, 2021, 2018 and 2015 IRC Section R703.7.2.1, 2012, 2009 and 2006 IRC Section R703.6.2.1 or UBC Section 2506.5, as applicable. Galvanized steel,  $1\frac{3}{8}$ -inch (35 mm), No. 22 gage [0.025-inch (0.635 mm)], J-shaped trim pieces shall be installed at other areas where insulation board is exposed. See [Figure 3](#) for typical installation details. At windows and doors, flashing must be installed in accordance with the 2021 and 2018 IBC Section 1404.4 (2015, 2012, and 2009 IBC Section 1405.4, 2006 IBC Section 1405.3), 2021, 2018 or 2015 IRC Section R703.4, or 2012, 2009 and 2006 IRC Section R703.8 or UBC Section 1402.2, as applicable. Holes for hose bibbs, electrical panels and other penetrations of substrate surfaces, except those caused by fasteners, shall also be caulked. The coating shall then be applied as described in Section 4.1.

**4.3.2 Wood Structural Panel Sheathing:** Wood structural panel sheathing must be applied directly to wood studs under conditions as set forth in Section 3.2.7 of this report and either the 2021, 2018 or 2015 IBC Table 2308.6.3(3), 2012, 2009 and 2006 IBC Table 2308.9.3(3), IRC Table R602.3(3) or UBC Table 23-IV-D-1, whichever code is applicable. The sheathing must be attached in accordance with the 2021 IBC Table 2304.10.2, 2018 or 2015 IBC Table 2304.10.1, 2012, 2009 and 2006 IBC Table 2304.9.1, IRC Table R602.3 (1) or UBC Table 23-II-B-1, as applicable. The water-resistive barrier, optional insulation board, wire-fabric lath and coating must be applied as described for fiberboard in Section 4.3.1. The balance of the system must be installed in accordance with Section 4.2.

**4.3.3 Gypsum Sheathing:** Minimum  $\frac{1}{2}$ -inch-thick (12.7 mm), water-resistant core-treated gypsum sheathing must be installed directly on wood studs spaced a maximum of 24 inches (610 mm) on center, in a manner similar to fiberboard. Gypsum sheathing must be fastened in accordance with ASTM C1280 (IBC), IRC Table R702.3.5 or UBC Table 25-G, as applicable.

A water-resistive barrier must be required over the gypsum sheathing prior to installation of the lath, optional insulation board, and coating as described in Section 4.3.1. All walls must be braced in accordance with the applicable code.

The system may also be applied to minimum No. 20 gage [0.035 inch (0.89 mm)] steel studs in the same manner, except the lath fastening is with No. 8 by minimum  $1\frac{3}{4}$ -inch-long (44 mm), self-drilling tapping screws spaced at 7 inches (178 mm) on center. Screws fastening sheathing, and screws fastening lath, must be staggered from each other. The screws must penetrate the framing and tracks a minimum of  $\frac{1}{4}$  inch (6.4 mm). The balance of system installation must be in accordance with Section 4.2.

**4.3.4 Concrete and Masonry:** Concrete and masonry surface preparation shall be in accordance with IBC Section 2510.7 or UBC Section 2508.8, as applicable. Surfaces of masonry, stone, or cast-in-place or precast concrete shall be clean and free of dust, oil, or other contaminants. Surfaces shall have good surface absorption and surface roughness to ensure proper bonding. The coating shall be applied directly to the prepared surface at a minimum thickness of  $\frac{3}{8}$  inch (9.5 mm) in accordance with applicable provisions of Section 4.1 of this report.

#### **4.4 One-hour Fire-resistance-rated Assemblies:**

##### **4.4.1 First Assembly:**

**4.4.1.1 Interior Face:** One layer of  $\frac{5}{8}$ -inch-thick (15.9 mm), Type X gypsum wallboard complying with ASTM C36 or ASTM C1396, water-resistant backer board or veneer base is applied parallel or at right angles to the interior face of 2-by-4 wood studs spaced a maximum of 24 inches (610 mm) on center. The wallboard is attached with 6d coated nails  $1\frac{7}{8}$  inches (48 mm) long with  $\frac{1}{4}$ -inch-diameter (6.4 mm) heads, at 7 inches (178

mm) on center to studs, plates and blocking. All wallboard joints must be backed with minimum 2-by-4 wood framing, taped and treated with joint compound in accordance with GA-216 or ASTM C840. Fastener heads must also be treated with joint compound in accordance with GA-216 or ASTM C840.

**4.4.1.2 Exterior Face:** One layer of minimum  $5/8$ -inch-thick (15.9 mm), Type X, water-resistant core-treated gypsum sheathing, complying with ASTM C79 or ASTM C1396 and 48 inches (1219 mm) wide, is applied parallel to studs with No. 11 gage galvanized roofing nails  $1\ 3/4$  inches (44.5 mm) long and having  $7/16$ -inch- or  $1/2$ -inch-diameter (11.1 mm or 12.7 mm) heads, at 4 inches (102 mm) on center at board edges and 7 inches (178 mm) on center at intermediate studs. The sheathing is nailed to top and bottom plates at 7 inches (178 mm) on center. A water-resistive barrier complying with Section 3.2.9.1 is required over the sheathing. The wire fabric lath and wall coating are then applied as described in Section 4.2.

**4.4.1.3 Axial Design:** The wood stud axial design stress for the system described in Section 4.4.1 is limited to  $0.78 F'_c$ , and the maximum stress shall not exceed  $0.78 F'_c$  at a maximum slenderness ratio ( $l_e/d$ ) of 33, as calculated in accordance with IBC Section 2306, IRC Section R602.3 or UBC Chapter 23, Division III, as applicable.

#### 4.4.2 Second Assembly:

**4.4.2.1 Interior Face:** One layer of  $5/8$ -inch-thick (15.9 mm), Type X gypsum wallboard, complying with ASTM C36 or ASTM C1396, is applied to the interior face of nominal 2-by-4 wood studs (minimum specific gravity of 0.50, such as Douglas fir) spaced a maximum of 16 inches on center. The wallboard is fastened with 2-inch-long

(51 mm), No. 11 gage roofing nails with minimum  $5/16$ -inch (7.9 mm) head diameter at 6 inches (152 mm) on center to all framing members. As an alternate, the gypsum board attachment may be with 6d cooler or wallboard nails at 7 inches (178 mm) on center as set forth in the applicable code. All wallboard joints must be backed with minimum 2-by-4 wood framing and taped and treated with joint compound in accordance with GA-216 or ASTM C840. Stud wall cavities are filled with  $3\ 5/8$ -inch-thick (92 mm), R-11 rockwool insulation, having a 1.8 pcf (28.8 kg/m<sup>3</sup>) density, which is attached to the framing members.

**4.4.2.2 Exterior Face:** A water-resistive barrier complying with Section 3.2.9.1 is applied over the exterior stud face followed by 1-inch-thick (25.4 mm) 1.5 pcf density (24 kg/m<sup>3</sup>) EPS board applied as described in Section 4.2. The No. 20 gage woven-wire mesh is then fastened through the EPS board to the wood framing with 2-inch-long (51 mm) No. 11 gage roofing nails having minimum  $5/16$ -inch-diameter (7.9 mm) heads at 6 inches (152 mm) on center. Ultrakote Stucco is then applied at least  $3/8$  inch (9.5 mm) thick as described in Section 4.1

**4.4.2.3 Axial Design (2-by-4 Wood Construction):** Axial loads applied to the system described in Section 4.4.2 are limited to the least of the following:

- 1,200 pounds (5340 N) per stud.
- A maximum of 50 percent of the load calculated in accordance with Sections 3.6 and 3.7 of ANSI AWC NDS (2021, 2018, 2015 and 2012 IBC and IRC), Sections 3.6 and 3.7 of ANSI/AF&PA NDS-05 (2009 and 2006 IBC and IRC) or ANSI/NFoPA NDS-91 (UBC), as applicable.
- Design stress of  $0.78 F'_c$  calculated in accordance with Sections 3.6 and 3.7 of ANSI AWC NDS (2021, 2018, 2015 and 2012 IBC and IRC), Sections 3.6 and 3.7 of ANSI/AF&PA NDS-05 (2009 and 2006 IBC and IRC) or ANSI/NFoPA NDS-91 (UBC), as applicable.
- Design stress of  $0.78 F'_c$  at a maximum slenderness ratio ( $l_e/d$ ) of 33, calculated in accordance with Sections 3.6 and 3.7 of ANSI AWC NDS (2021, 2018, 2015 and 2012 IBC and IRC), Sections 3.6 and 3.7 of ANSI/AF&PA NDS-05 (2009 and 2006 IBC and IRC) or ANSI/NFoPA NDS-91 (UBC), as applicable.

**4.4.2.4 Axial Design (2-by-6 Wood Construction):** Axial loads applied to the system described in Section 4.4.2 are limited to the least of the following:

- 3,000 pounds (13350 N) per stud up to 10 feet (3.05 m) high or 1,200 pounds (5340 N) per stud for greater heights.
- A maximum of 44.7 percent of the load calculated in accordance with Sections 3.6 and 3.7 of ANSI AWC NDS (2021, 2018, 2015 and 2012 IBC and IRC), Sections 3.6 and 3.7 of ANSI/AF&PA NDS-05 (2009 and 2006 IBC and IRC) or ANSI/NFoPA NDS-91 (UBC), as applicable.

- Design stress of  $0.78 F'_c$  calculated in accordance with Sections 3.6 and 3.7 of ANSI AWC NDS (2021, 2018, 2015 and 2012 IBC and IRC), Sections 3.6 and 3.7 of ANSI/AF&PA NDS-05 (2009 and 2006 IBC and IRC) or ANSI/NFoPA NDS-91 (UBC), as applicable.
- Design stress of  $0.78 F'_c$  at a maximum slenderness ratio ( $l_e/d$ ) of 33, calculated in accordance with Sections 3.6 and 3.7 of ANSI AWC NDS (2021, 2018, 2015 and 2012 IBC and IRC), Sections 3.6 and 3.7 of ANSI/AF&PA NDS-05 (2009 and 2006 IBC and IRC) or ANSI/NFoPA NDS-91 (UBC), as applicable.

#### 4.4.3 Third Assembly:

**4.4.3.1 Interior Face:** One layer of  $5/8$ -inch-thick (15.9 mm), Type X gypsum wallboard, complying with ASTM C36 or ASTM C1396, is applied horizontally or vertically to the interior face of 2-by-4 wood studs (minimum specific gravity of 0.50, such as Douglas fir) spaced a maximum of 24 inches (610 mm) on center. The wallboard is fastened to the studs and perimeter framing using  $17/8$ -inch-long (48 mm), 0.100-inch-diameter (2.54 mm) galvanized steel cup head drywall nails, having a minimum head diameter of 0.300 inch (7.62 mm), spaced a maximum of 7 inches (178 mm) on center. All wallboard joints must be taped and treated with joint compound in accordance with GA-216 or ASTM C840. All vertical joints in the wallboard must occur over studs. Fastener heads must also be taped and treated with joint compound. Kraft paper faced fiberglass insulation batts are placed in the cavities between the studs with the kraft paper surface on the interior side of the wall, and fastened to the studs. The insulation batts have an R-11 thermal resistance value, and measure  $3\frac{1}{2}$  inches (89 mm) thick.

**4.4.3.2 Exterior Face:** One layer of minimum  $7/16$ -inch-thick (11.1 mm) OSB rated-sheathing, one layer of minimum  $15/32$ -inch-thick (11.9 mm) plywood or one layer of minimum  $1/2$ -inch-thick (12.7 mm), water-resistant core-treated gypsum sheathing, complying with ASTM C79, is applied vertically to the wall, and fastened to the wood studs, sills and plates using  $17/8$ -inch-long (48 mm) by6d coated sinker nails spaced a maximum of 8 inches (203 mm) on center. All vertical joints in the OSB rated-sheathing, plywood or gypsum board must occur over studs. Two layers of Grade D building paper shall be applied to the exterior face and attached to the wood studs. One layer of wire fabric lath described in Section 3.2.5.1 is fastened through the sheathing to the studs with  $1\frac{1}{4}$ -inch-long-by-No.-16-gage-by-1-inch-crown staples, spaced 6 inches (152 mm) on center along all studs and perimeter framing. The Ultrakote One-Kote Stucco System mixture is then applied to the lath in accordance with Section 4.1 at a minimum thickness of  $3/8$  inch (9.5 mm). For studs of 10 feet or greater length, mid-height blocking between studs is required.

**4.4.3.3 Axial Design (2-by-4 Wood Construction):** Axial loads applied to the system described in Section 4.4.3 are limited to the least of the following:

- 1,100 pounds (4895 N) per stud.
- A maximum of 47.5 percent of the load calculated in accordance with Sections 3.6 and 3.7 of ANSI AWC NDS (2021, 2018, 2015 and 2012 IBC and IRC), Sections 3.6 and 3.7 of ANSI/AF&PA NDS-05 (2009 and 2006 IBC and IRC) or ANSI/NFoPA NDS-01 (UBC), as applicable.
- Design stress of  $0.78 F'_c$  calculated in accordance with Section 3.6 and 3.7 of ANSI AWC NDS (2021, 2018, 2015 and 2012 IBC and IRC), Sections 3.6 and 3.7 of ANSI/AF&PA NDS-05 (2009 and 2006 IBC and IRC) or ANSI/NFoPA NDS-91 (UBC), as applicable.
- Design stress of  $0.78 F'_c$  at a maximum slenderness ratio ( $l_e/d$ ) of 33, calculated in accordance with Sections 3.6 and 3.7 of ANSI AWC NDS (2021, 2018, 2015 and 2012 IBC and IRC), Sections 3.6 and 3.7 of ANSI/AF&PA NDS-05 (2009 and 2006 IBC and IRC) or ANSI/NFoPA NDS-91 (UBC), as applicable.

**4.4.3.4 Axial Design (2-by-6 Wood Construction):** Axial loads applied to the system described in Section 4.4.2 are limited to the least of the following:

- 3000 pounds (13350 N) per stud up to 10 feet (3.05 m) high or 1,100 pounds (4895 N) per stud for greater heights.
- A maximum of 44.7 percent of the load calculated in accordance with Sections 3.6 and 3.7 of ANSI AWC NDS (2021, 2018, 2015 and 2012 IBC and IRC), Sections 3.6 and 3.7 of ANSI/AF&PA NDS-05 (2009 and 2006 IBC and IRC) or ANSI/NFoPA NDS-91 (UBC), as applicable.
- Design stress of  $0.78 F'_c$  calculated in accordance with Section 3.6 and 3.7 of ANSI AWC NDS (2021, 2018, 2015 and 2012 IBC and IRC), Sections 3.6 and 3.7 of ANSI/AF&PA NDS-05 (2009 and 2006 IBC and IRC) or ANSI/NFoPA NDS-91 (UBC), as applicable.
- Design stress of  $0.78 F'_c$  at a maximum slenderness ratio ( $l_e/d$ ) of 33, calculated in accordance with Sections 3.6 and 3.7 of ANSI AWC NDS (2021, 2018, 2015 and 2012 IBC and IRC), Sections 3.6 and 3.7 of ANSI/AF&PA NDS-05 (2009 and 2006 IBC and IRC) or ANSI/NFoPA NDS-91 (UBC), as applicable.

#### 4.5 Noncombustible (Types I, II, III and IV) Construction:

The stucco system, without EPS, may be installed on exterior walls required to be noncombustible (Types I, II, III and IV) construction as indicated in Sections 4.5.1 through 4.5.4. When installed on exterior walls greater than 40 feet (12.2 m) above grade, the water-resistive barrier must comply with Exception 2 of the 2021 and 2018 IBC Section 1402.5 (2015 IBC Section 1403.5). Under 2012 IBC Section 1403.5, the system must be installed on exterior walls having a maximum height of 40 feet (12.2 m) above grade.

**4.5.1 Exterior Finish:** One layer  $\frac{5}{8}$ -inch-thick (15.9 mm), water-resistant, Type X gypsum sheathing complying with ASTM C79 or ASTM C1396 is applied vertically to steel framing with all edges blocked. Fasteners are No. 8 by  $1\frac{1}{4}$ -inch-long (32 mm) buglehead screws fastened to board joints at 8 inches (203 mm) on center and intermediate locations at 12 inches (305 mm) on center. All joints are taped and treated with joint compound in accordance with GA-216 or ASTM C840. Intermediate fasteners are treated with compound in accordance with GA-216 or ASTM C840. A water-resistive barrier in compliance with Section 3.2.9.1 is required over the gypsum sheathing. The lath is attached through the water-resistive barrier to metal studs as set forth in Section 4.2. Screws fastening sheathing and screws fastening lath must be staggered. Ultrakote stucco is applied at a minimum  $\frac{3}{8}$ -inch (9.5 mm) thickness as described in Section 4.1.

**4.5.2 Steel Framing:** Minimum  $3\frac{5}{8}$ -inch-deep (92 mm), No. 20 gage steel studs [0.035 inch (0.89 mm) thick] spaced a maximum of 16 inches (406 mm) on center.

**4.5.3 Openings:** Wall openings are framed with minimum 0.125-inch-thick (3.2 mm) tubular aluminum or steel framing.

**4.5.4 Interior Finish:** Interior finish consists of  $\frac{5}{8}$ -inch (15.9 mm), Type X gypsum wallboard attached as noted for exterior finish.

#### 4.6 Miscellaneous:

**4.6.1 Inspection Requirements:** Building department inspection is required on lath installation prior to application of the coating as noted in the 2021, 2018, 2015, 2012 and 2009 IBC Section 110.3.5 and 2006 IBC Section 109.3.5 for areas enforcing the IBC or IRC, or UBC Section 108.5.5 for areas enforcing the UBC, as applicable.

**4.6.2 Control Joints:** Control joints to be installed as specified by the architect, designer, builder or exterior coating manufacturer, in that order. In the absence of details, control joints must be located in accordance with ASTM C1063 for three-coat plaster.

**4.6.3 Curing:** Moist curing must be provided for 48 hours after coating application.

**4.6.4 Soffits:** The system may be applied to soffits, provided the coating is applied over metal lath complying with Section 3.2.5.2 of this report in lieu of wire fabric lath. Expanded metal lath fastening must comply with IBC Section 2510.3, 2021, 2018 or 2015 IRC Section R703.7.1, 2012, 2009 and 2006 IRC Section R703.6.1.3.5, or UBC Table 25-C, as applicable, except the length must be increased by the thickness of any substrate.

**4.6.5 Sills:** The system may be applied to sills at locations such as windows and other similar areas. Sills with depths of 6 inches (152 mm) or less may have the coating and lath applied to any substrate permitted in this report, provided the coating, lath, water-resistive barrier and substrate are installed in accordance with the appropriate section of this report. Sills with depths exceeding 6 inches (152 mm) must have substrates of solid wood or plywood. The substrate must be fastened in accordance with 2021 IBC Table 2304.10.2, 2018 or 2015 IBC Table 2304.10.1, 2012, 2009 and 2006 IBC Table 2304.9.1, IRC Section R602.3 or UBC Table 23-II-B-1, as applicable, and a double layer of Grade D water-resistive barrier must be applied over the substrate. The lath, optional insulation board and coating must be applied in accordance with Section 4.2.

## 5.0 CONDITIONS OF USE:

The Ultrakote One-Kote Stucco System described in this report complies with, or is a suitable alternative to what is specified in, those codes listed in Section 1.0 of this report, subject to the following conditions:

- 5.1 The materials and methods of installation comply with this report and the manufacturer's instructions. In the event of a conflict between the manufacturer's published installation instructions and this report, this report governs. The manufacturer's published installation instructions must be available at the jobsite at all times during construction.
- 5.2 Installation is by contractors approved by the manufacturer.
- 5.3 The system is recognized as a one-hour fire-resistance-rated assembly when complying with Section 4.4.
- 5.4 The coating system is limited to Type V (IBC and UBC), or construction permitted by the IRC, except when installed in accordance with Section 4.5.



- 5.5 In areas enforcing the UBC, the coating system, without insulation board, may be attached to the surface of combustible exterior fire-resistive assemblies described in UBC Table 7B without a change in the assigned hourly rating of the assembly.
- 5.6 The interior of the building must be separated from the insulation board with a thermal barrier complying with IBC Section 2603.4, 2021, 2018, 2015, 2012 and 2009 IRC Section R316.4, 2006 IRC Section R314.4 and IRC Table R702.3.5, or UBC Section 2602.4 and UBC Table 25-G, as applicable.
- 5.7 An installation card, as shown in [Figure 2](#), must be completed and left at the jobsite for the owner, and a copy is filed with the building department.
- 5.8 The allowable wind load on the system with wood or steel studs a maximum of 24 inches (610 mm) on center is 35 lbf/ft<sup>2</sup> (1915 Pa) negative and 40 lbf/ft<sup>2</sup> positive. Supporting framing must be adequate to resist the required wind load, with a maximum allowable deflection of 1/240 of the span.
- 5.9 Foam plastic must not be placed on exterior walls of wood construction located within 6 inches (152 mm) of the ground in areas where hazard of termite damage is very heavy in accordance with the 2021, 2018 or 2015 IBC Section 2603.8, 2012 IBC Section 2603.9, 2009 and 2006 IBC Section 2603.8, 2018, 2015, 2012 and 2009 IRC Section 318.4, or 2006 IRC Section R320.5, as applicable.

## 6.0 EVIDENCE SUBMITTED

Data in accordance with the [ICC-ES Acceptance Criteria for Cementitious Exterior Wall Coatings \(AC11\)](#), dated January 2013 (editorially revised October 2020).

## 7.0 IDENTIFICATION

- 7.1 The factory-prepared mix is delivered to the jobsite in water-resistant bags with labels bearing the following information:
  - a. Name and address of manufacturer (Ultrakote Products, Inc.); the product name (Ultrakote); and evaluation report number (ESR-1471).
  - b. Identification of components.
  - c. Weight of packaged mix.
  - d. Storage instructions.
  - e. Maximum amount of water and other components that may be added and conditions that must be considered in determining actual amount.
  - f. Curing instructions

Insulation boards are identified in accordance with their respective evaluation reports. Additionally, the board's density must be noted.

- 7.2 The report holder's contact information is the following:

**ULTRAKOTE PRODUCTS, LLC**  
**327 SOUTH 27<sup>TH</sup> AVENUE**  
**PHOENIX, ARIZONA 85009**  
**(602) 272-5830**  
[www.ultrakoteproducts.com](http://www.ultrakoteproducts.com)

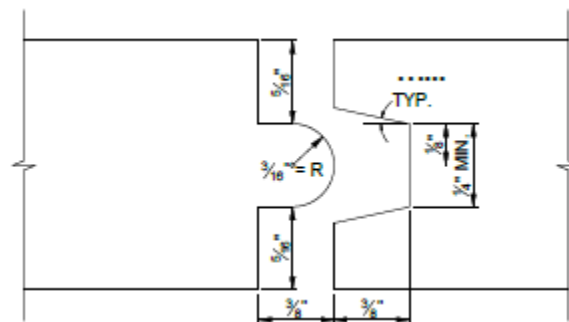

FIGURE 1—TONGUE-AND-GROOVE INSULATION BOARD



# UltraKote™

FIBER - REINFORCED STUCCO

327 South 27th Avenue - Phoenix, AZ 85009 - (602) 272-5830

## INSTALLATION CARD

ICC Report No. ESR-1471

Job Address: \_\_\_\_\_  
\_\_\_\_\_  
\_\_\_\_\_

**Plastering Contractor**

Name: \_\_\_\_\_  
Address: \_\_\_\_\_  
Telephone No. \_\_\_\_\_

Approved contractor number as issued by Ultrakote Products, LLC: \_\_\_\_\_

This is to certify that the exterior coating system on the building exterior at the above address has been installed in accordance with the evaluation report specified above and the manufacturer's instructions.

Signature of authorized representative of plastering contractor

Date

This installation card must be presented to the building inspector after completion of work and before final inspection.

[www.ultrakoteproducts.com](http://www.ultrakoteproducts.com)



FIGURE 2

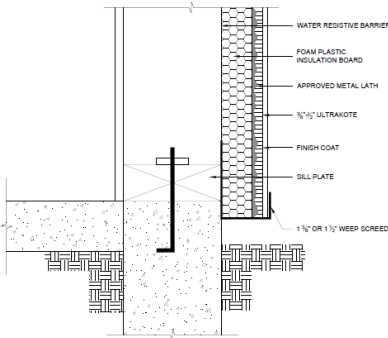

WEEP SCREED—FOAM SUBSTRATE 01

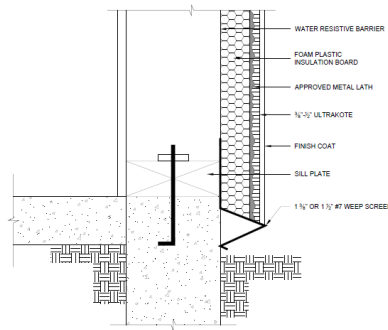

WEEP SCREED—FOAM SUBSTRATE 02

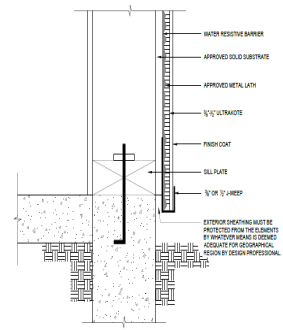

WEEP SCREED—SOLID SUBSTRATE

FIGURE 3

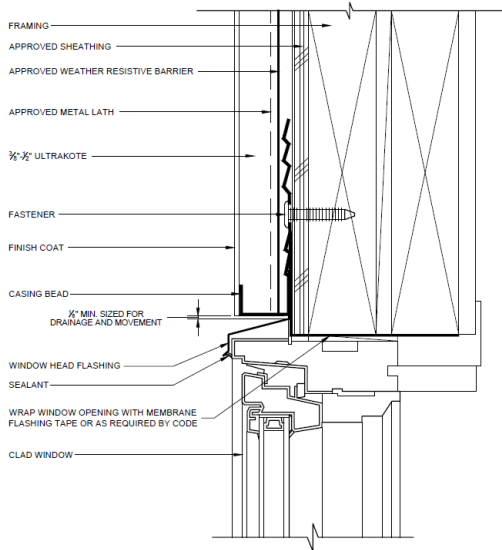

TYPICAL WINDOW AND DOOR HEAD

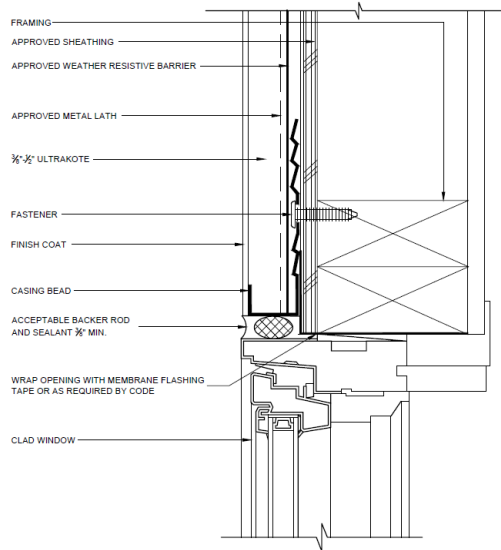

TYPICAL WINDOW AND DOOR JAMB

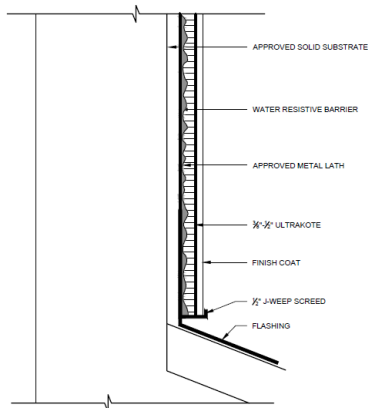

TERMINATION AT FLASHING ON ROOF - SOLID SUBSTRATE

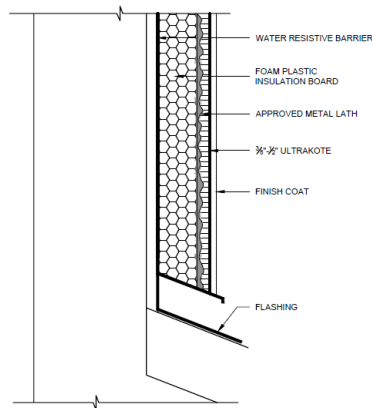

TERMINATION AT FLASHING ON ROOF - FOAM SUBSTRATE

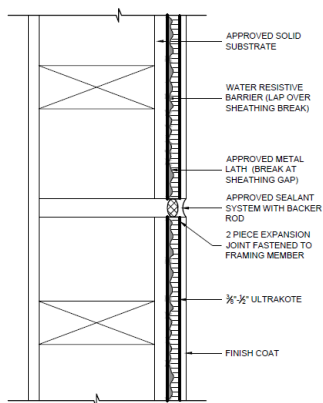

EXPANSION JOINT

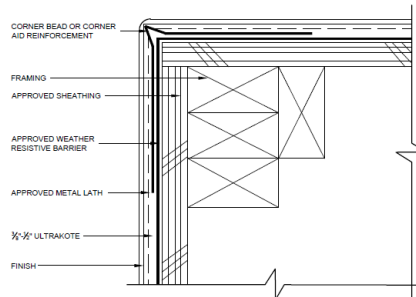

TYPICAL CORNER BEAD DETAIL

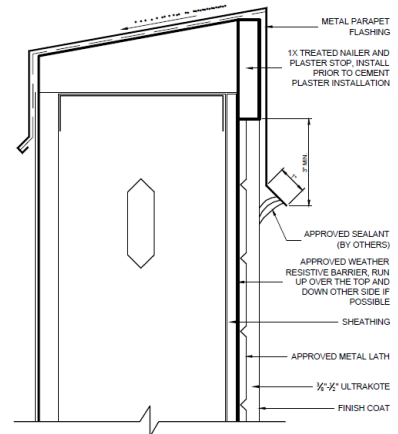

TYPICAL METAL PARAPET CAP

FIGURE 3 (continued)

DIVISION: 09 00 00—FINISHES

Section: 09 24 00—Portland Cement Plastering

## REPORT HOLDER:

ULTRAKOTE PRODUCTS, LLC

## EVALUATION SUBJECT:

ULTRAKOTE ONE-KOTE STUCCO SYSTEM

## 1.0 REPORT PURPOSE AND SCOPE

## Purpose:

The purpose of this evaluation report supplement is to indicate that the Ultrakote One-Kote Stucco System, described in ICC-ES evaluation report ESR-1471, has also been evaluated for compliance with the codes noted below.

## Applicable code editions:

- 2022 California Building Code (CBC)

For evaluation of applicable Chapters adopted by the California Office of Statewide Health Planning and Development (OSHPD) AKA: California Department of Health Care Access and Information (HCAI) and the Division of State Architect (DSA), see Sections 2.1.1 and 2.1.2 below.

- 2022 California Residential Code (CRC)

## 2.0 CONCLUSIONS

## 2.1 CBC:

The Ultrakote One-Kote Stucco System, described in Sections 2.0 through 7.0 of the evaluation report ESR-1471, complies with CBC Chapter 25, provided the design and installation are in accordance with the 2021 *International Building Code*® (IBC) provisions noted in the evaluation report and the additional requirements of CBC Chapters 23, 25 and 26, as applicable.

**2.1.1 OSHPD** The applicable OSHPD Sections and Chapters of the CBC are beyond the scope of this supplement.

**2.1.2 DSA** The applicable DSA Sections and Chapters of the CBC are beyond the scope of this supplement.

## 2.2 CRC:

The Ultrakote One-Kote Stucco System, described in Sections 2.0 through 7.0 of the evaluation report ESR-1471, complies with CRC Chapter 7, provided the design and installation are in accordance with the 2021 *International Residential Code*® (IRC) provisions noted in the evaluation report.

This supplement expires concurrently with the evaluation report, reissued September 2023.