

ICC-ES Evaluation Report

ESR-1374

Reissued June 2024

This report also contains:

- CBC Supplement

Subject to renewal June 2025

ICC-ES Evaluation Reports are not to be construed as representing aesthetics or any other attributes not specifically addressed, nor are they to be construed as an endorsement of the subject of the report or a recommendation for its use. There is no warranty by ICC Evaluation Service, LLC, express or implied, as to any finding or other matter in this report, or as to any product covered by the report.

Copyright © 2024 ICC Evaluation Service, LLC. All rights reserved.

<p>DIVISION: 09 00 00— FINISHES</p> <p>Section: 09 80 00— Acoustic Treatment</p>	<p>REPORT HOLDER: HOMASOTE COMPANY</p>	<p>EVALUATION SUBJECT: HOMASOTE INSULATING BOARDS: HOMASOTE 440 SOUNDBARRIER®; COMFORTBASE®; HOMEX® 300; NOVA CORK; BURLAP PANEL; 440 PINnacle™ BOARD</p>	
--	---	--	---

1.0 EVALUATION SCOPE

Compliance with the following codes:

- 2018, 2015, 2012, 2009 and 2006 [International Building Code® \(IBC\)](#)
- 2018, 2015, 2012, 2009 and 2006 [International Residential Code® \(IRC\)](#)
- 2013 *Abu Dhabi International Building Code (ADIBC)*[†]

[†]The ADIBC is based on the 2009 IBC. 2009 IBC code sections referenced in this report are the same sections in the ADIBC.

Properties evaluated:

- Fire resistance
- Surface-burning characteristics
- Sound transmission

2.0 USES

Homasote insulating boards are used in nonstructural applications for interior and protected exterior wall finish materials, as sound insulation and expansion joint materials. The Homasote 440 SoundBarrier® is also recognized for use in fire-resistance-rated assemblies.

3.0 DESCRIPTION

Homasote boards are made of approximately 98 percent recycled paper fibers, 2 percent paraffin wax and less than 0.1 percent copper metaborate. All products are free of asbestos, formaldehyde, urea and phenolic additives. In the descriptions of specific boards in Sections 3.1 through 3.6, all product dimensions are nominal.

3.1 Homasote 440 SoundBarrier®:

Homasote 440 SoundBarrier® is a lightweight sound-deadening material, weighing 25 to 29 pounds per cubic foot (400 to 460 kg/m³). The boards are installed as flooring underlayment on top of wood subflooring and concrete, and between gypsum board and studs in walls. Homasote 440 has a flame-spread index of not greater than 200 and a smoke-developed index of not greater than 450. The standard sizes of the boards are as follows:

THICKNESS	PANEL SIZE in feet (mm)
1/2-inch	4 feet by 4 feet (1219 mm by 1219 mm)
	4 feet by 8 feet (1219 mm by 2438 mm)
	4 feet by 10 feet (1219 mm by 3048 mm)
5/8-inch	4 feet by 4 feet (1219 mm by 1219 mm)
	4 feet by 8 feet (1219 mm by 2438 mm)
3/4-inch	4 feet by 8 feet (1219 mm by 2438 mm)

3.2 ComfortBase®:

ComfortBase® is similar to 440 SoundBarrier, weighing 25 to 29 pounds per cubic foot (400 to 460 kg/m³). It is designed to be used as an underlayment over concrete surfaces and allows concrete to release moisture without causing panels to curl or bow. ComfortBase® fiberboard has a flame-spread index of not greater than 200 and a smoke-developed index of not greater than 450. ComfortBase® is available in panels that are nominally 1/2 inch thick and that measure a nominal 4 feet by 4 feet.

3.3 Homex® 300:

Homex® 300 is made from approximately 98 percent recycled paper fibers with 2 percent paraffin wax and less than 0.1 percent copper metaborate. The panels weigh 25 to 29 pounds per cubic foot (400 to 460 kg/m³). These panels are used as isolation/expansion joint material in areas where masonry or concrete walls meet outside aprons, walks, patios or steps. Other uses include light-duty concrete forming in such applications as walkways, patios, pool aprons, and driveways. Homex® 300 is available in nominally 1/2-inch-thick strips that may be 3, 3 1/2, 4 or 6 inches wide and 8 or 10 feet long. Homex 300® is also available as 4-foot-by-10-foot-by-1/2-inch-thick panels for custom applications, excluding interior finishes.

3.4 Nova Cork:

Nova Cork is a factory-prefinished interior paneling composed of natural virgin cork laminated to one side or both sides of Homasote 440 fiberboard. The panels are available in 4-foot-by-8-foot and 4-foot-by-10-foot sizes, and weigh 25 to 29 pounds per cubic foot (400 to 460 kg/m³). Nova Cork has a flame-spread index of not greater than 75 and a smoke-developed index of not greater than 450.

3.5 Burlap Panel:

Burlap Panel is a factory-prefinished interior paneling composed of an all-natural heavyweight jute fabric laminated to a Homasote 440 fiberboard. The panels are available in a 1/2-inch nominal thickness and a 4-foot width, and in lengths of 8 feet and 10 feet. The panels weigh 25 to 29 pounds per cubic foot (400 to 460 kg/m³). Burlap Panel has a flame-spread index of not greater than 200 and a smoke-developed index of not greater than 450.

3.6 440 PINnacle™ Board:

The 440 PINnacle™ Board is used for interior and protected exterior use. The boards are finely sanded, with a suede-like feel to the touch. The panels are available in 3/8-inch and 1/2-inch nominal thicknesses, and are 4 feet wide and 8 feet long. The panels weigh 25 to 29 pounds per cubic foot (400 to 460 kg/m³). The 440 PINnacle™ Board has a flame-spread index of not greater than 75 and a smoke-developed index of not greater than 450. This product is the prefinished version of the 440 SoundBarrier®.

4.0 DESIGN AND INSTALLATION

4.1 General:

The Homasote panels must be installed in accordance with the manufacturer's published installation instructions and this report. The manufacturer's published installation instructions and this report must be strictly adhered to, and a copy of the instructions and this evaluation report must be available on the jobsite during installation.

When installed with components described in [Table 1](#), the assemblies provide a minimum Sound Transmission Class (STC) of 50 and a minimum Impact Insulation Class (IIC) of 50, as required in Section 1206 of the 2018 IBC (Section 1207 of the 2015, 2012, 2009 and 2006 IBC).

4.2 Fire-resistance Rating:

4.2.1 Fire-resistance Wall Rating: The fire-resistance-rated assembly shown in [Figure 1](#) is based on a UL design. Homasote 440 SoundBarrier[®] may be used in fire-resistance-rated wall assembly when constructed as indicated in the design. When using this assembly, all details must be in accordance with the specifications contained in the UL *BXUV GuideInfo*.

4.2.2 Fire-resistance Floor and Ceiling Rating: The fire-resistance-rated assembly shown in [Figure 2](#) is based on a UL design. Homasote 440 SoundBarrier[®] may be used in fire-resistance-rated floor/ceiling assembly when constructed as indicated in the design. When using these assemblies, all details must be in accordance with the specifications contained in UL *BXUV GuideInfo*.

5.0 CONDITIONS OF USE:

The Homasote Boards described in this report comply with, or are suitable alternatives to what is specified in, those codes listed in Section 1.0 of this report, subject to the following conditions:

- 5.1 Homasote insulation board is not to be used as a plaster base.
- 5.2 All products must be installed in a dry condition.
- 5.3 The boards are limited to installation in Type V construction (IBC) and structures constructed in accordance with the IRC.

6.0 EVIDENCE SUBMITTED

- 6.1 Reports of testing in accordance with ASTM E84.
- 6.2 Reports of acoustical testing in accordance with ASTM E90 and ASTM E492.
- 6.3 Reports of testing in accordance with ASTM C209, as required by ASTM C208.
- 6.4 Reports of testing and analysis in accordance with UL 263 (ASTM E119).
- 6.5 Quality documentation.
- 6.6 Manufacturer's installation instructions.

7.0 IDENTIFICATION

- 7.1 The Homasote products covered by this report, or their packaging, must be marked for identification with the name of the manufacturer (Homasote Company), the product name, the statement "Complies with ASTM C208, Type I," and the evaluation report number (ESR-1374).
- 7.2 The report holder's contact information is the following:

HOMASOTE COMPANY
932 LOWER FERRY ROAD
WEST TRENTON, NEW JERSEY 08628-0240
(609) 883-3300, ext. 1332
www.homasote.com
sgleason@homasote.com

TABLE 1—ACOUSTICAL RATINGS OF HOMASOTE[®] FLOOR-CEILING ASSEMBLIES

	Assembly 1: STC 56 – IIC 54	Assembly 2: STC 62 – IIC 70	Assembly 3: STC 55 – IIC 51	Assembly 4: STC 58 – IIC 58
Luxury Vinyl Tile	X		X	X
3/4" Hardwood		X		
1/2" 440 Sound Barrier [®]	X	X	X	X
3/4" OSB			X	X
3/4" Wood Subfloor	X	X		X
12" deep I-Joist with a minimum 1-3/8" deep by 2-1/4" wide flange material and 3/8" thick web material				X
9-1/2" deep I-Joist with a minimum 1-3/8" deep by 1-3/4" wide flange material and 3/8" thick web material			X	
Nominal 4" wide x 18" deep Open Web Joist	X			
3-1/2" Fiberglass Insulation	X			
6" Fiberglass Insulation		X	X	X
Resilient Channels			X	X
Hat Channels	X			
5/8" Type X Gypsum Board		X		
5/8" Type C Gypsum Board	X			
2 Layers of 5/8" Type X Gypsum Board			X	X
6" Concrete Slab		X		
Drop Ceiling		X		
Sound Isolation Clips	X			

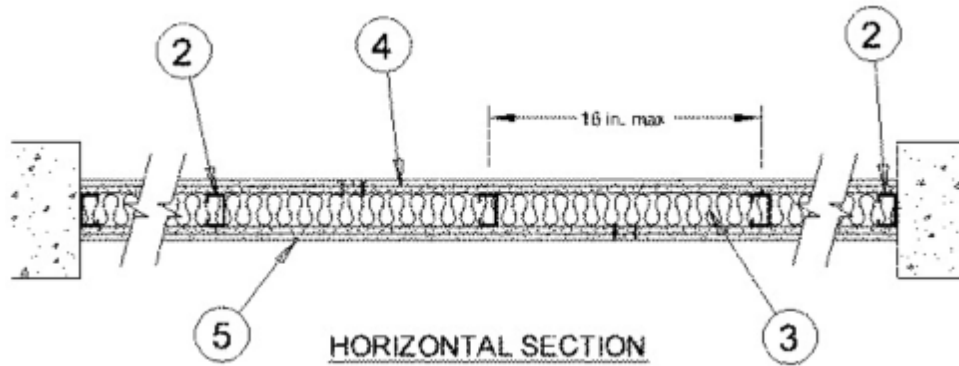

FIGURE 1—Nonbearing Wall Rating—1 HR.

1. **Floor and Ceiling Runner**— (Not Shown)—Channel shaped, attached to floor and ceiling with steel fasteners spaced maximum 36 inches on center. Fabricated from min No. 25 MSG galv steel, $3\frac{5}{8}$ inch deep and minimum $1\frac{1}{4}$ inch wide.
2. **Steel Studs**—Channel shaped, spaced a maximum 16 inches on center. Fabricated from minimum 25 MSG galv steel, minimum $3\frac{5}{8}$ inch wide by $1\frac{1}{4}$ inch deep with $\frac{1}{4}$ inch folded back return flange legs. Studs to be cut $\frac{3}{8}$ inch less the assembly height. Steel studs friction-fitted into ceiling runners (Item 1). Studs attached to floor runners with $\frac{7}{16}$ inch long Type S-12 pan-head, self-drilling, self-tapping steel screws on both sides of the studs or by welded or bolted connections designed in accordance with the AISI specifications. Where required for lateral support of studs, support shall be provided by means of steel straps, channels or other similar means as specified in the design of a particular steel stud wall system.
3. **Batts and blankets***—Nominal 3-inch-thick, minimum 3.4 pcf mineral wool batts, friction fit between the studs and floor and ceiling runners.
4. **Mineral and Fiber Board***—Nominal $\frac{1}{2}$ -inch-thick, 4-foot-wide Homasote Type 440-32 Sheathing. Installed with long dimension parallel with studs. Vertical joints centered on studs, and staggered one stud space from opposite side. Attached to studs with Type S-12 inch long steel screws, spaced 12 inches on center along interior studs at perimeter of panels.
5. **Gypsum Board***— $\frac{5}{8}$ -inch-thick, 4-foot-wide. One layer of wallboard applied vertically over the mineral and fiber board with joints centered between studs and staggered minimum 16 inches on opposite sides, secured with Type S-10, $1\frac{1}{2}$ inch long screws spaced 12 inches on center along the perimeter and 16 inches on center in the field.
6. **Joint Tape and Compound**—(Not Shown)—Outer layer joints covered with joint compound and paper or mesh tape. Screw heads covered with joint compound.

HOMASOTE CO—Homasote Type 440-32.

CANADIAN GYPSUM COMPANY—Types C, IP-X2.

UNITED STATES GYPSUM CO—Types C, IP-X2.

USG MEXICO S A DE C V—Types C, IP-X2.

*Bearing the UL Classification Mark

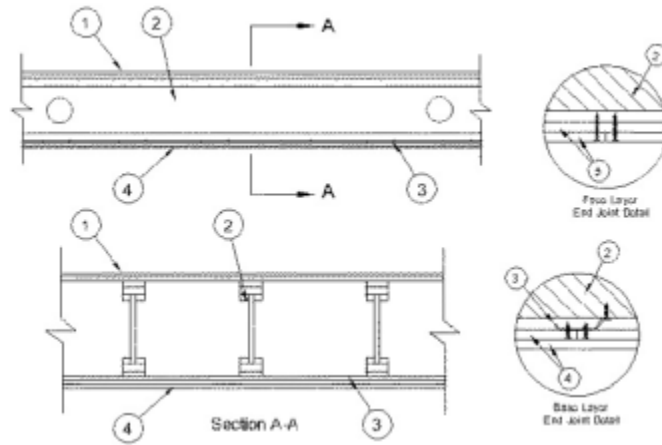

FIGURE 2—Unrestrained Assembly Rating—1 1/2 Hour Finish Rating—60 Minute

1. **Flooring System**—The flooring system shall consist of one of the following:

Subflooring—Minimum 5/8-inch-thick plywood wood structural panels, minimum grade "Underlayment" or "Single-Floor". Face grain of plywood to be perpendicular to trusses with joints staggered.

Finish Floor - Mineral and Fiber Board*—Minimum 1/2-inch-thick, supplied in sizes ranging from 3 feet by 4 feet to 8 feet by 12 feet. All joints to be staggered a minimum of 12 inches with adjacent sub-floor joints.

HOMASOTE CO—Type 440-32 Mineral and Fiber Board

2. **Structural Wood Members**—Minimum 9 1/2 inches deep "I" shaped wood joists spaced max 19.2 inches on center, and blocked at the ends using 2 inch by 10 inch wood members. Minimum joists bearing on bearing plates shall be 5 1/2 inches. Joists are secured to the bearing plates with two 8d or 10d nails at each end. Circular holes may be cut in the web of joists in accordance with the Weyerhaeuser's published installation instructions.

I-Joist—TJI® 360 and TJI® 560 (ESR-1153)

3. **Resilient Channels**—Resilient channels, 3/8 inch deep by 2 3/8 inch wide at the base and 1 3/8 inch wide at the face, formed from No. 25 MSG galv steel, spaced 16 inches on center perpendicular to joists. Channels secured to each truss with 1 5/8 inch long Type S bugle head steel screws. As an alternate to the resilient channels, **Steel Framing Members*** (Item 3A) may be used.

- 3A. **Steel Framing Members - (Not Shown)***—As an alternate to Item 3, furring channels and **Steel Framing Members*** as described below:

- a. **Furring Channels**—Formed of No. 25 MSG galv steel, 2 9/16 inches or 2 23/32 inches wide by 7/8 inches deep, spaced 24 inches on center perpendicular to joists. Channels secured to trusses as described in Item b. Ends of adjoining channels overlapped 6 inches and tied together with a double strand of No. 18 SWG galvanized steel wire near each end of overlap.

- b. **Steel Framing Members***—Used to attach furring channels (Item a) to joists (Item 2). Clips spaced 48 inches on center and secured to alternating joists with No. 8 x 2 1/2 inch coarse drywall screw through the center

grommet. Furring channels are friction fitted into clips. RSIC-1 clip is for use with 2 9/16 inches wide furring channels. RSIC-1 (2.75) clip is for use with 2 23/32 inches wide furring channels. Adjoining channels are overlapped as described in Item a. As an alternate, ends of adjoining channels may be overlapped 6 inches and secured together with two self-tapping No. 6 framing screws, minimum 7/16 inch long at the midpoint of the overlap, with one screw on each flange of the channel. Additional clips required to that supports the gypsum board butt joints, as described in Item 4.

PAC INTERNATIONAL INC—Type RSIC-1, RSIC-1 (2.75)

4. **Gypsum Board**—Two layers of 1/2-inch-thick-by-4-foot-wide gypsum board installed perpendicular to resilient channels. Base layer secured to resilient channels with 1 inch long Type S bugle head screws spaced 8 inches on center at the butted end joints and 16 inches on center in the field of the board. Face layer secured to resilient channels with 1 5/8 inch Type S bugle head screws spaced 8 inches on center in the field of the board and with 1 1/2 inch long Type G screws spaced 8 inches on center at the butt joints located midspan between resilient channels. When **Steel Framing Members** (Item 3A) are used, gypsum board installed with long dimension parallel with trusses. Base layer attached to the furring channels using 1 inch long Type S bugle head steel screws spaced 12 inches on center in the field of the board. Butted end joints shall be staggered minimum 2 feet within the assembly, and occur midway between the continuous furring channels. At butted end joints, each end of each gypsum board shall be supported by a single length of furring channel equal to the width of the gypsum board plus 6 inches on each end. The two furring channels shall be spaced approximately 3 1/2 inches on center, and be attached to underside of the joist with one RSIC-1 clip or RSIC-1 (2.75) clip at each end of the channel. Screw spacing along the end joint shall be 8 inches on center. Butted base layer end joints to be offset a minimum of 24 inches in adjacent courses. Outer layer attached to the furring channels using 1 5/8 inch long Type S bugle-head steel screws spaced 8 inches on center at butted joints and 12 inches on center in the field. Butted end joints to be offset a minimum of 8 inches from base layer end joints. Butted side joints of outer layer to be offset minimum 18 inches from butted side joints of base layer.

UNITED STATES GYPSUM CO—Type C

*Bearing the UL Classification Mark

DIVISION: 09 00 00—FINISHES**Section: 09 80 00—Acoustic Treatment****REPORT HOLDER:****HOMASOTE COMPANY****EVALUATION SUBJECT:****HOMASOTE INSULATING BOARDS: HOMASOTE 440 SOUNDBARRIER®; COMFORTBASE®; HOMEX® 300; NOVA CORK; BURLAP PANEL; 440 PINnacle™ BOARD****1.0 REPORT PURPOSE AND SCOPE****Purpose:**

The purpose of this evaluation report supplement is to indicate that Homasote insulating boards, described in ICC-ES evaluation report ESR-1374, have also been evaluated for compliance with the codes noted below.

Applicable code editions:

- 2019 *California Building Code (CBC)*

For evaluation of applicable chapters adopted by the California Office of Statewide Health Planning and Development (OSHPD) AKA: California Department of Health Care Access and Information (HCAI) and the Division of State Architect (DSA), see Sections 2.1.1 and 2.1.2 below.

- 2019 *California Residential Code (CRC)*

2.0 CONCLUSIONS**2.1 CBC:**

The Homasote insulating boards, described in Sections 2.0 through 7.0 of the evaluation report ESR-1374, comply with CBC Chapter 12, provided the design and installation are in accordance with the 2018 *International Building Code*® (IBC) provisions noted in the evaluation report.

2.1.1 OSHPD:

The applicable OSHPD Sections and Chapters of the CBC are beyond the scope of this supplement.

2.1.2 DSA:

The applicable DSA Sections and Chapters of the CBC are beyond the scope of this supplement.

2.2 CRC:

The Homasote insulating boards, described in Sections 2.0 through 7.0 of the evaluation report ESR-1374, complies with CRC Appendix K, provided the design and installation are in accordance with the 2018 *International Residential Code*® (IRC) provisions noted in the evaluation report.

This supplement expires concurrently with the evaluation report, reissued June 2024.