

ICC-ES Evaluation Report

ESR-1112

Reissued May 2024

This report also contains:

- CBC Supplement

Subject to renewal May 2026

- FBC Supplement

ICC-ES Evaluation Reports are not to be construed as representing aesthetics or any other attributes not specifically addressed, nor are they to be construed as an endorsement of the subject of the report or a recommendation for its use. There is no warranty by ICC Evaluation Service, LLC, express or implied, as to any finding or other matter in this report, or as to any product covered by the report.

Copyright © 2024 ICC Evaluation Service, LLC. All rights reserved.

<p>DIVISION: 03 00 00— CONCRETE</p> <p>Section: 03 51 13— Cementitious Wood Fiber Decks</p> <p>DIVISION: 06 00 00— WOOD, PLASTICS AND COMPOSITES</p> <p>Section: 06 12 00— Structural Panels</p> <p>Section: 06 12 13— Cementitious Reinforced Panels</p> <p>DIVISION: 09 00 00— FINISHES</p> <p>Section: 09 84 00— Acoustic Room Components</p>	<p>REPORT HOLDER: TECTUM, INC.</p>	<p>EVALUATION SUBJECT: TECTUM I, TECTUM III, TECTUM IIIW, TECTUM E AND TECTUM V ROOF DECK PANELS</p>	
---	---	---	---

1.0 EVALUATION SCOPE

Compliance with the following code:

- 2024, 2021, 2018 and 2015, 2012, 2009 and 2006 [International Building Code® \(IBC\)](#)

Properties evaluated:

- Structural
- Fire performance

2.0 USES

Tectum I, Tectum III, Tectum IIIW, Tectum E and Tectum V panels are used for roof deck construction Tectum I panels are also used as acoustical panels and suspended ceiling tiles.

3.0 DESCRIPTION

3.1 Tectum I Panels:

Tectum I panels are composed of wood fibers impregnated and bonded together into slab form with mineral cements. The panels vary in thickness from 1 inch (25 mm) to 3 inches (76 mm) and have widths up to 48 inches (1219 mm) and lengths up to 192 inches (4877 mm). Tectum I panels are available as Tectum I planks, Tectum I long-span planks and Tectum I roof tiles.

Tectum I planks have $\frac{1}{2}$ -inch (13 mm) tongues and grooves on the long edges.

Tectum I Long-span planks have tongue-and-groove edges on long edges and incorporate $\frac{3}{4}$ -inch-deep-by- $\frac{1}{2}$ -inch-wide (19 mm by 13 mm) or $1\frac{1}{2}$ -inch-deep-by- $\frac{1}{2}$ -inch-wide (38 mm by 13 mm), No. 16 gage [0.0635 inch (1.65 mm) base-metal thickness] galvanized steel channels that are installed in the groove side of the panel.

Tectum I roof tiles have a $\frac{1}{2}$ -inch-wide (13 mm) rabbet along the long edge of the tiles for installation between bulb tees or truss tees, which are attached to the top of, and span between, supporting members as described in Section 4.3.

3.2 Tectum III Panels:

Tectum III panels are factory-assembled composite panels with a core consisting of $1\frac{1}{2}$ -inch- to 6-inch-thick (38 mm to 152 mm) Dow Chemical Co. Styrofoam Panel Core, a Styrofoam Brand extruded polystyrene foam plastic insulation board, complying with ASTM C578, Type IV. The foam plastic core is factory-bonded, with a Type II Class 2 adhesive complying with ICC-ES Acceptance Criteria for Sandwich Panel Adhesives (AC05), to facings of minimum $1\frac{1}{2}$ -inch-thick (38 mm) Tectum I panels on the bottom face and minimum $\frac{7}{16}$ -inch-thick (11 mm) oriented strand board (OSB) or minimum $\frac{1}{2}$ -inch-thick (12.7 mm) plywood complying with DOC PS-2 on the top face. Tectum III panels are available as Tectum III planks and as Tectum III roof tiles in widths up to 48 inches (1219 mm) and lengths up to 192 inches (4877 mm).

Tectum III planks have $\frac{1}{2}$ -inch-deep (13 mm) tongues and grooves along the long edges of the Tectum I plank layer, while Tectum III roof tiles have a $\frac{1}{2}$ -inch-wide (13 mm) rabbet on the long edges of the tiles for installation between bulb tees or truss tees attached to the top of, and spanning between, supporting members, as noted in Section 4.4.

Tectum III panels are mechanically and adhesively fastened to all support members as noted in Sections 4.1 and 4.4. See [Figure 1](#) for typical edge details and [Figure 2](#) for typical end conditions.

3.3 Tectum IIIW Panels:

Tectum IIIW panels are factory-assembled composite panels with a core consisting of 3-inch- to 8-inch-thick (76 to 203 mm) Dow Chemical Co. Styrofoam Panel Core, a Styrofoam Brand extruded polystyrene foam plastic insulation board, complying with ASTM C578, Type IV. The foam plastic core is factory-bonded, with a Type II Class 2 adhesive complying with ICC-ES AC05, to facings of minimum $1\frac{1}{2}$ -inch-thick (38 mm) Tectum I panel on the bottom face and minimum $\frac{19}{32}$ -inch-thick (15 mm) plywood complying with DOC PS-2 on the top face. Tectum IIIW panels are available as Tectum IIIW planks and as Tectum IIIW roof tiles in widths up to 48 inches (1219 mm) and lengths up to 192 inches (4877 mm).

Tectum IIIW planks have $\frac{1}{2}$ -inch-deep (13 mm) tongues and grooves along the long edge in the Tectum I plank layer, while Tectum IIIW roof tiles have a $\frac{1}{2}$ -inch-wide (13 mm) rabbet on the long edge of the tiles for installation between bulb tees or truss tees attached to the top of, and spanning between, supporting members, as noted in Section 4.4.

Tectum IIIW panels are mechanically and adhesively fastened to all support members as noted in Sections 4.1 and 4.4. See [Figure 1](#) for typical edge details and [Figure 2](#) for typical end conditions.

3.4 Tectum E Panels:

Tectum E panels are factory-assembled composite panels with a core consisting of $\frac{3}{4}$ -inch- to $6\frac{1}{2}$ -inch-thick (19 mm to 165 mm) expanded polystyrene foam plastic insulation core addressed in a current ICC-ES evaluation report and complying with ASTM C578, Type I. The foam plastic core is factory-bonded to facings of minimum $1\frac{1}{2}$ -inch-thick (38 mm) Tectum I panels on the bottom face and minimum $\frac{7}{16}$ -inch-thick (11 mm) OSB or minimum $\frac{1}{2}$ -inch-thick (12.7 mm) plywood complying with DOC PS-2 on the top face, with a Type II Class 2 adhesive complying with ICC-ES AC05. Panels are available as Tectum E roof planks and Tectum E roof tiles in widths up to 48 inches (1219 mm) and lengths up to 192 inches (4877 mm).

Tectum E roof planks have $\frac{1}{2}$ -inch-deep (13 mm) tongues and grooves along the long edges in the Tectum I panel layer. Tectum E roof tiles have a $\frac{1}{2}$ -inch-wide (13 mm) rabbet joint on the long edges of the Tectum panel layer for installation between bulb tees or truss tees attached to the top of and spanning between supporting members as noted in Section 4.4.

Tectum E roof planks and Tectum E roof tiles are mechanically and adhesively fastened to all supporting members, as noted in Section 4.1. See [Figure 1](#) for typical edge details and [Figure 2](#) for typical end conditions.

3.5 Tectum V Panels:

Tectum V panels are factory-assembled composite roof panels consisting of, from the bottom face layer to the top face layer; minimum $1\frac{1}{2}$ -inch-thick (38.1 mm) Tectum I panels, $\frac{1}{2}$ -inch-thick (12.7 mm) expanded polystyrene (EPS) foam plastic core complying with ASTM C578, Type I, minimum $\frac{7}{16}$ -inch-thick (11 mm)

oriented strand board (OSB) or minimum $\frac{1}{2}$ -inch-thick (12.7 mm) plywood complying with DOC PS-2, 6-inch-thick (152.4 mm) EPS foam plastic core complying with ASTM C578, Type I, and minimum $\frac{7}{16}$ -inch-thick (11 mm) OSB or minimum $\frac{1}{2}$ -inch-thick (12.7 mm) plywood complying with DOC PS-2. The layers are factory-bonded with Type II, Class 2 adhesives complying with ICC-ES AC05. Tectum V panels are available as planks in width up to 48 inches (1219 mm) and length up to 192 inches (4877 mm).

Tectum V panels are manufactured with Tectum I panels having a $\frac{1}{2}$ -inch-deep (12.7 mm) tongue and groove along the long edges and are mechanically and adhesively fastened to supporting members, as noted in Section 4.1. See [Figure 1](#) for typical edge details and [Figure 2](#) for typical end conditions.

3.6 Acoustical Board and Suspending Ceiling Tile:

The acoustical boards and suspended ceiling tiles are fabricated from 1- to 2-inch-thick (25 to 51 mm) Tectum I panels and are available in various sizes with square, beveled or face-rabbeted edges. Panels with face-rabbeted edges are also available in maximum 3-inch (76 mm) thicknesses. The acoustical boards and suspended ceiling tiles may be installed between suspended ceiling runners, directly to substrate, to steel subpurlins or to furring strips spaced 24 inches (610 mm) on center on walls or ceilings.

3.7 Thermal Barrier:

Tectum I, III, IIIW, E and V panels are qualified as thermal barriers for use in separating foam plastic insulation from the interior of a building under IBC Section 2603.4 provided the edges are tongue-and-groove, covered with a 1-inch-thick (25 mm) wood strip, or joints are filled with a solid gypsum cement grout or 3M fire barrier sealant designated CP 25WB+ intumescent when minimum $\frac{1}{2}$ -inch-thick Tectum I is used as a thermal barrier.

3.8 Interior Finish:

Tectum I panels have a flame-spread index of not more than 25 and a smoke-developed index of not more than 450, when tested in accordance with ASTM E84. The panels are therefore classified as Class A interior finish in accordance with IBC Section 803.

4.0 DESIGN AND INSTALLATION

4.1 General:

The manufacturer's published installation instructions and this report shall be strictly adhered to and a copy of these must be available on the jobsite during installation. The instructions within this report govern if there are any conflicts between the manufacturer's instructions and this report.

All panels must be installed with the long dimension of the panel perpendicular to the continuous supports. All panels must be fastened to wood framing with screws that penetrate into the framing at least 1 inch (25 mm), unless otherwise noted in this report. All panels must be fastened to steel supports with screws long enough to penetrate the steel at least $\frac{1}{2}$ inch (13 mm), unless otherwise noted in this report.

Tectum I panels must be attached to supporting members with screws and must be adhesively attached along tongue-and-groove edge joints and to supports in accordance with Section 4.3. See [Figure 1](#) for typical Tectum I panel edge details, and [Figure 2](#) for typical connections. See [Table 1](#) for allowable gravity loads, spans, panel thicknesses and required support member widths.

The Tectum III/IIIW panels must be placed over steel, wood or concrete framing on flat or sloped roofs with the Tectum I facing placed face down towards the interior of the building. Maximum center-to-center spacing of supports with associated allowable gravity loads is noted in [Tables 2](#) and [3](#).

The Tectum V panels must be placed over steel framing on flat roofs with the Tectum I facing panel placed towards the interior of the building. Plywood splines must be used at panel joints, as shown in [Figure 2](#). The maximum center-to-center spacing of supports and the associated allowable gravity loads are noted in [Table 5](#). On concrete supports, a steel or wood insert must be cast in the concrete for installation. Screws for Tectum I panels must be Construction Fasteners, Inc., Dekfast 14 [0.234-inch-diameter (6 mm) shaft, 0.441-inch-diameter (11 mm) head] screws with 2-inch-diameter (51 mm) with $\frac{1}{2}$ -inch-diameter (38 mm) Construction Fasteners, Inc., washers. Screws for Tectum III and Tectum E panels must be Dekfast 14 screws with $\frac{1}{2}$ -inch-diameter (38 mm) Construction Fastener, Inc., washers; or SIP screws [0.194-inch-diameter (5 mm) shaft, 0.610-inch-diameter (16 mm) head]. When adhesion is required, a continuous $\frac{3}{8}$ -inch-diameter (10 mm) bead of Miracle Construction adhesive, meeting the requirements of APA Specification AFG-01 and of caulking gun consistency, must be used.

4.2 Tectum I, III, IIIW, E, and V Plank Screwed/Glued Roof Diaphragm:

Product thickness, fastenings, supports and diaphragm length-to-width ratios are set forth for Tectum I planks in [Table 10](#); and in [Table 11](#) for Tectum I long-span planks, 3-inch-thick (76 mm) Tectum I planks, and Tectum III/IIIW, Tectum E and Tectum V planks. Tectum I diaphragms addressed in [Table 11](#) require No. 22 gage

[0.0336 inch (0.85 mm) base-metal thickness], galvanized steel nailing strips, 1¹/₂ inches (38 mm) wide at the periphery and 4 inches (102 mm) wide over supporting subpurlins.

Tectum planks must be laid with the long edge perpendicular to purlins and square-edge supported ends staggered in adjacent rows. Unsupported tongue-and-groove edges between adjacent rows must be adhered to each other with a ³/₈-inch (10 mm) continuous bead of Miracle Construction adhesive placed in the groove of each plank, and the tongue-and-groove joints must be driven tight. Each supported square-edge end must be butted tight against the adjacent plank. At each supported square-edge end and where planks are continuous over purlins, the planks must be adhered to the purlins or the diaphragm boundary supports with a ³/₈-inch (10 mm) continuous bead of adhesive and must also be attached to supports with screws. The minimum length of planks must be sufficient to span three purlins, except for end filler to accommodate staggered joint installation.

4.3 Tectum I Roof Tile Diaphragm:

Tectum I roof tiles, 2 inches (51 mm) or more in thickness and 31¹/₂ inches (800 mm) wide, must be grouted with gypsum concrete (ASTM C317 Class A) between truss tees of a minimum size of 000-5-14-2. The truss tees must be welded to steel structural supports using a 1-inch (25 mm) fillet weld on each side of the tee at each support. The supports must be spaced a maximum of 96 inches (2438 mm) on center. Tile ends must be attached with two screws per panel end and glued using a ³/₈-inch (10 mm) bead of construction adhesive. The perimeter of the diaphragm must be attached using a ³/₈-inch (10 mm) bead of Miracle Construction adhesive and screws with 2-inch (51 mm) diameter washers spaced at 10¹/₂ inches (267 mm) on center. Screws must be minimum No. 11 gage [0.200 inch (5.08 mm)] and the adhesive must meet the requirements of APA Specification AFG-01. Allowable shear value is 280 pounds per linear foot (4086 N/m).

4.4 Tectum III/IIIW and Tectum E Roof Tile Diaphragm:

Tectum III/IIIW and Tectum E roof tiles, 3¹/₂ inches (89 mm) or more in thickness and 47¹/₂ inches (1206 mm) wide, must be grouted between truss tees of a minimum size of 000-3-14-3¹/₂. The truss tees must be welded to steel structural supports using a 1-inch (25 mm) fillet weld on each side of the tee at each support. The supports must be spaced a maximum of 96 inches (2438 mm) on center. Tile ends must be attached with three Dekfast 14 screws with 1¹/₂-inch-diameter (38 mm) washers per tile end, and must be glued using a ³/₈-inch-diameter (10 mm) bead of construction adhesive. The boundary of the diaphragm must be attached to supports using a ³/₈-inch-diameter (10 mm) bead of Miracle Construction adhesive and screws with 1¹/₂-inch-diameter (38 mm) washers spaced at 12 inches (305 mm) on center. Screws must be a minimum of No. 14 gage [0.240 inch (6.10 mm)] and the adhesive must meet the requirements of APA Specification AFG-01. Allowable shear value is 310 pounds per linear foot (4553 N/m).

4.5 Tectum IIIW Roof Diaphragm:

Tectum IIIW panels have square ends with a tongue-and-groove joint along the long edge. The tongue and groove of each panel interlock with a ³/₈-inch (9.5 mm) bead of construction adhesive meeting the requirements of AFG-01. Panel ends are adhered together with a ³/₈-inch (9.5 mm) bead of construction adhesive. Panels are screw attached with a ³/₁₆-inch (5 mm) diameter by 7-inch (178 mm) Trufast flat head screw and 1-¹/₂-inch (38 mm) diameter-by-¹/₁₆-inch (2 mm) thick steel washers located 6-inches (150 mm) from each end and spaced 12-inches (300 mm) on center with a minimum 2-inch (50 mm) penetration into the supports.

4.6 Wind Uplift:

Uplift resistance for Tectum I, III, IIIW, E and V panels fastened with screws is noted in [Tables 6, 7, 8](#) and [9](#).

4.7 Special Inspection:

Special inspection in accordance with IBC Chapter 17 is required where diaphragm construction incorporates adhesives. The special inspector must verify adhesive type, placement, and curing. Special inspections for wind resistance must comply with IBC Section 1705.12 (2018 and 2015 IBC Section 1705.11). Special inspections for seismic resistance must comply with IBC Section 1705.13 (2018 and 2015 IBC Section 1705.12).

5.0 CONDITIONS OF USE:

The Tectum I, Tectum III, IIIW, Tectum E, and Tectum V Roof Deck Panels described in this report comply with, or are suitable alternatives to what is specified in, those codes listed in Section 1.0 of this report, subject to the following conditions:

- 5.1 The roof deck panels must be installed in accordance with the Tectum Inc. published installation instructions, this evaluation report and the applicable code. If there are any conflicts between the Tectum Inc. published installation instructions and this evaluation report, this evaluation report governs.
- 5.2 The Tectum I, Tectum III, Tectum IIIW, Tectum E, and Tectum V Roof Deck Panels are for use in buildings of Type III or V construction or in buildings of Types I and II construction where fire-retardant-treated wood

is allowed in accordance with IBC Section 603.1(1). When use is as an alternative to fire-retardant-treated wood, the allowable spans for Tectum III, Tectum IIIW, Tectum E, and Tectum V panels are limited to the span of Tectum I, supported by 3-inch-wide purlins, noted in [Table 1](#).

- 5.3 When used as roof decks, the Tectum III, Tectum IIIW, Tectum E and Tectum V roof deck panels must be a component of a Class A, B, or C roof covering assembly.
- 5.4 The Tectum I decks, with a 1³/₄-inch (44 mm) minimum thickness may be used as a roof deck in applications where Type IV-HT (Type IV for the 2018 and 2015 IBC) construction is allowed. Decking must be a minimum of 20 feet (6 m) above the floor immediately below.
- 5.5 Structural calculations must be submitted to the code official. Calculations and drawings must be prepared, signed and sealed by a registered design professional where required by the statutes of the jurisdiction in which the project is to be constructed.
- 5.6 For use as diaphragms, structural calculations must be submitted to the code official. Calculations and drawings must be prepared, signed and sealed by a registered design professional where required by the statutes of the jurisdiction in which the project is to be constructed.
- 5.7 The panels must be covered with an approved roof covering immediately after installation and must not be left exposed to the weather.
- 5.8 Panels with a maximum allowable uniform load of less than 50 psf must be limited to roof applications that are not subject to the concentrated live loads specified in IBC Table 1607.1 Item 28 (Item 27 for the 2021 IBC; Item 26 for the 2018 and 2015 IBC).
- 5.9 The products are manufactured under a quality control program with inspections by ICC-ES.

6.0 EVIDENCE SUBMITTED

- 6.1 Reports of tests for gravity load capacity, full-scale diaphragm load capacity, flame spread and smoke-developed indices, and wind uplift.
- 6.2 Reports of room fire tests in accordance with UBC Standard 26-3 (UL 1715).
- 6.3 Quality documentation in accordance with the [ICC-ES Acceptance Criteria for Quality Documentation \(AC10\)](#).

7.0 IDENTIFICATION

- 7.1 The ICC-ES mark of conformity, electronic labeling, or the evaluation report number (ICC-ES ESR-1112) along with the name, registered trademark, or registered logo of the report holder must be included in the product label.
- 7.2 In addition, labels attached to stacks, skid loads, and crates of the Tectum products bear the product name, the panel size, the quantity and the manufacturing date.
- 7.3 The report holder's contact information is the following:

TECTUM INC.
105 SOUTH 6TH STREET
NEWARK, OHIO 43055
(740) 755-4322
www.armstrongceilings.com

TABLE 1—ALLOWABLE ROOF DECK SPANS FOR TECTUM I PANELS

NOMINAL THICKNESS (inches)	WEIGHT (psf)	ALLOWABLE SPANS (inches) ²			
		4-inch-wide Purlins			3-inch-wide Purlins
		35 psf Design Load ¹	40 psf Design Load ¹	45 psf Design Load ¹	50 psf Design Load ¹
1½	2.4	---	---	---	24
2	3.5	42	40	38	36
2½	4.5	48	46	44	42
3	5.3	54	52	50	48
2 long span	3.8	60	---	---	48
2½ long span	4.7	66	---	---	60
3 long span	5.5	---	---	---	72

For SI: 1 inch = 25.4 mm, 1 psf = 0.0479 kPa.

¹The tabulated design load is the allowable superimposed load for use in allowable stress (strength) design (ASD) and does not include the weight of the Tectum plank.

²Center to center of supports.

TABLE 2—ALLOWABLE ROOF DECK SPANS FOR TECTUM III PANELS^{1,5}

NOMINAL THICKNESS (inches)	WEIGHT (psf)	ALLOWABLE SPANS ³ (inches)		
		30 psf Superimposed Design Load	50 psf Superimposed Design Load	60 psf Superimposed Design Load
3½	4.4	---	72 ⁴	---
4	4.6	---	72 ²	---
5	5.0	96 ²	---	72 ²
8	5.5	---	96 ²	---

For SI: 1 inch = 25.4 mm, 1 psf = 0.0479 kPa.

¹Values limited to a maximum deflection of L/240 where L is the span in inches.

²Support conditions require a minimum 4-inch bearing width.

³Center to center of supports.

⁴Support conditions require a minimum 2½-inch bearing width.

⁵Tabulated loads are allowable superimposed loads for use in ASD.

TABLE 3—ALLOWABLE ROOF DECK SPANS FOR TECTUM IIIW PANELS^{1,2,4}

NOMINAL THICKNESS (inches)	WEIGHT (psf)	ALLOWABLE SPANS ³ (inches)					
		30 psf Superimposed Design Load	40 psf Superimposed Design Load	50 psf Superimposed Design Load	60 psf Superimposed Design Load	70 psf Superimposed Design Load	80 psf Superimposed Design Load
6	4.8	117	101	90	82	76	71
7	5.1	120	112	100	92	85	79
8	5.2	—	120	109	100	92	86

For SI: 1 inch = 25.4 mm, 1 psf = 0.0479 kPa.

¹Values limited to a maximum deflection of L/240 where L is the span in inches.

²Support conditions require a minimum 4-inch bearing width.

³Center to center of supports.

⁴Tabulated loads are allowable superimposed loads for use in ASD.

TABLE 4—ALLOWABLE ROOF DECK SPANS FOR TECTUM E PANELS^{1,2,4}

NOMINAL THICKNESS (inches)	WEIGHT (psf)	ALLOWABLE SPANS ³ (inches)	
		40 psf Superimposed Design Load	50 psf Superimposed Design Load
2 ³ / ₄	4.4	---	48
4	4.6	72	60
5	5.0	---	72
6	5.2	---	84
8 ¹ / ₂	5.5	---	96

For SI: 1 inch = 25.4 mm, 1 psf = 0.0479 kPa.

¹Values limited to a maximum deflection of L/240 where L is the span in inches.

²Support conditions require a minimum 4-inch bearing width.

³Center to center of supports.

⁴Tabulated loads are allowable superimposed loads for use in ASD.

TABLE 5—ALLOWABLE ROOF DECK SPANS FOR TECTUM V PANELS^{1,2,4}

NOMINAL THICKNESS (inches)	WEIGHT (psf)	ALLOWABLE SPANS ³ (inches)		
		55 psf Superimposed Design Load	60 psf Superimposed Design Load	65 psf Superimposed Design Load
9	6.0	141	133	126

For SI: 1 inch = 25.4 mm, 1 psf = 0.0479 kPa.

¹Values limited to a maximum deflection of L/240, where L is the span in inches.

²Support conditions require a minimum 4-inch bearing width.

³Center to center of supports.

⁴Tabulated loads are allowable superimposed loads for use in ASD.

TABLE 6—ALLOWABLE UPLIFT RESISTANCE FOR TECTUM I DECKS^{1,2,3}

PANEL WIDTH (inches)	SPAN (inches)	SCREWS PER JOIST	UPLIFT RESISTANCE FOR 1-INCH SCREW PENETRATION IN WOOD (psf)	UPLIFT RESISTANCE FOR ATTACHMENT TO STEEL OR 1.5-INCH SCREW PENETRATION IN WOOD (psf)
31	24	2	110	130
47	24	2	73	86
31	36	2	74	87
47	36	2	49	57
47	36	3	73	86
31	42	2	63	74
47	42	2	42	49
47	42	3	63	74
31	48	2	55	65
31	48	3	83	98
47	48	2	37	43
47	48	3	55	65
31	60	2	37	44
31	60	3	55	65
31	72	2	30	35
31	72	3	46	54

For SI: 1 inch = 25.4 mm, 1 psf = 0.0479 kPa.

¹Screws are Dekfast No. 14 screws with a 2-inch-diameter washer described in Section 4.1.

²Values are based on screws acting alone (without contribution from adhesive) and panels installed in a two-span condition.

³Wood framing must have a minimum assigned specific gravity of 0.50.

TABLE 7—ALLOWABLE UPLIFT RESISTANCE OF TECTUM III AND TECTUM E DECK¹

PANEL WIDTH (inches)	SPAN (inches)	SCREWS PER JOIST	UPLIFT RESISTANCE FOR 1-INCH SCREW PENETRATION IN WOOD (psf) ²	UPLIFT RESISTANCE FOR ATTACHMENT TO STEEL (psf) ³
47	48	2	50	69
47	48	3	75	104
47	60	3	60	83
47	60	4	79	110
47	72	3	50	69
47	72	4	66	92
47	84	3	43	59
47	84	4	57	79
47	96	3	37	52
47	96	4	50	69

For SI: 1 inch = 25.4 mm, 1 psf = 0.0479 kPa.

¹Values are based on screws acting alone (without contribution from adhesive) and panels installed in a two-span condition.

²Screws are SIP screws described in Section 4.1. Wood framing must have a minimum assigned specific gravity of 0.50.

³Screw are Dekfast No. 14 screws described in Section 4.1.

TABLE 8—ALLOWABLE UPLIFT RESISTANCE OF TECTUM IIIW DECK¹

PANEL WIDTH (inches)	SPAN (inches)	SCREWS PER JOIST	UPLIFT RESISTANCE FOR 2-INCH SCREW PENETRATION IN WOOD (psf) ²
47	36	4	214
47	42	4	183
47	48	4	160
47	60	4	110
47	72	4	107

For SI: 1 inch = 25.4 mm, 1 psf = 0.0479 kPa

¹Values are based on screws acting alone and panels installed in a two-span condition.

²Screws are Trufast flat head screw as described in Section 4.5.

³Wood framing must have a minimum assigned specific gravity of 0.50

TABLE 9—UPLIFT RESISTANCE OF TECTUM V PANEL SPANS^{1,2}

NOMINAL THICKNESS (inches)	WEIGHT (psf)	ALLOWABLE SPANS ³ (inches)					
		55 psf Superimposed Design Load		60 psf Superimposed Design Load		65 psf Superimposed Design Load	
		Multiple Span	Single Span	Multiple Span	Single Span	Multiple Span	Single Span
9	6.0	122	141	113	133	105	126

For SI: 1 inch = 25.4 mm, 1 psf = 0.0479 kPa.

¹Values limited to a maximum deflection of $L/240$, where L is the span in inches.

²Support conditions require a minimum 4-inch bearing width.

³Center to center of supports.

TABLE 10—TECTUM I PLANK ALLOWABLE DIAPHRAGM SHEAR FOR WIND OR SEISMIC LOAD (plf)^{5,6,7}

THICKNESS (inches)	WOOD PURLINS OR WOOD NAILERS BOLTED TO METAL PURLINS											METAL PURLINS				
	Length-to-Width Ratio ¹						Length-to-Width Ratio Not Over 2:1			Length-to-Width Ratio Not Over 3:1		Length-to-Width Ratio Not Over 3:1				
	Screw Size	Unblocked Diaphragm, Uniform Screw Spacing on Supports ^{2,3}		Blocked Diaphragm, Uniform Screw Spacing on All Panel Edges ²		Unblocked Diaphragm, Screws Spaced 4 inches o.c. through Metal Strips ^{2,3}			Unblocked Diaphragm, Screws Spaced 4 inches o.c. through Metal Strip and Glued ³			Unblocked Diaphragm, Screws Spaced 8 inches o.c. through Metal Strip and Glued ³			Unblocked Diaphragm, Self-tapping Screws Spaced 8 inches o.c. through Metal Strip and Glued ³	
		3-inch Purlin Width ⁴		3-inch Purlin Width ⁴		Screw Size	3-inch Purlin Width ⁴	4-inch Purlin Width ⁴	Screw Size	3-inch Purlin Width ⁴	4-inch Purlin Width ⁴	Screw Size	3-inch Purlin Width ⁴	4-inch Purlin Width ⁴	Screw Size	4-inch Nominal Top Flange Width
4" o.c.	2" o.c.	4" o.c.	2" o.c.													
2	3 1/2" 14 ga	140	200	200	350	3 1/2" 14 ga	175	175	3 1/2" 14 ga	230	300	3 1/2" 14 ga	200	250	3/16"	250
2 1/2	4" 14 ga	140	200	200	350	4" 14 ga	---	200	4" 14 ga	250	330	4" 14 ga	210	280	3/16"	280
3	----	---	---	---	---	4 1/2" 14 ga	---	200	4 1/2" 14 ga	250	360	4 1/2" 14 ga	220	300	3/16"	300

For SI: 1 inch = 25.4 mm, 1 plf = 14.6 N/m.

The diaphragm deflection limit for masonry or concrete construction must be determined as follows:

$$\Delta p = \frac{h^2 f}{0.01(E_w)(t)}$$

where:

- Δ_p = Allowable diaphragm deflection, inches.
- H = Unsupported height of the wall, feet.
- F = Allowable flexural compressive strength of the wall, pounds per square inch.
- E_w = Modulus of elasticity of the wall, pounds per square inch.

[Table 10](#) notes continued on the next page.

Table 10 notes continued from the previous page.

The diaphragm deflection is determined by the formula:

$$\Delta d = \Delta s + \Delta b = \frac{(F)(Q_{avg})(L)}{2 \times 10^6} + \frac{5wL^4 \times 1728}{384EI}$$

where:

- Δ_d = Total diaphragm deflection, inches.
- Δ_s = Shear deflection, inches.
- Δ_b = Bending deflection, inches.

$$F = \frac{33,000Q_{avg}}{(Q_d)^2}$$

(For a diaphragm having a uniform shear distribution across its span)

- Q_{avg} = Average unit shear on diaphragm in pounds per foot between points for which deflection is to be determined. (For a simply supported diaphragm, uniformly loaded, " Q_{avg} " is equal to the actual diaphragm shear per foot divided by two.)
- Q_d = Allowable diaphragm shear in pounds per foot from table.
- W = Uniform load on diaphragm in pounds per foot.
- L = Diaphragm span, feet.
- E = Modulus of elasticity of diaphragm chord, psi.
- I = Moment of inertia of chords, inches⁴.

¹The diaphragm length-to-width ratio for wood frame construction must not exceed 3:1.

²Values may be increased one-fourth if the boundary fastening of the diaphragm has the screw spacing reduced one-half.

³Values must be decreased one-fourth when continuous unblocked joints are parallel to the direction of horizontal forces.

⁴Purlin widths are nominal dimensions.

⁵In addition to screw fastening, all boards must be fastened to one another at tongue-and-groove edge joints and to supports with ³/₈-inch-diameter bead of adhesive.

⁶Minimum thickness of structural steel support must be 0.20 inch.

⁷The planks are oriented to the load and framing as follows:

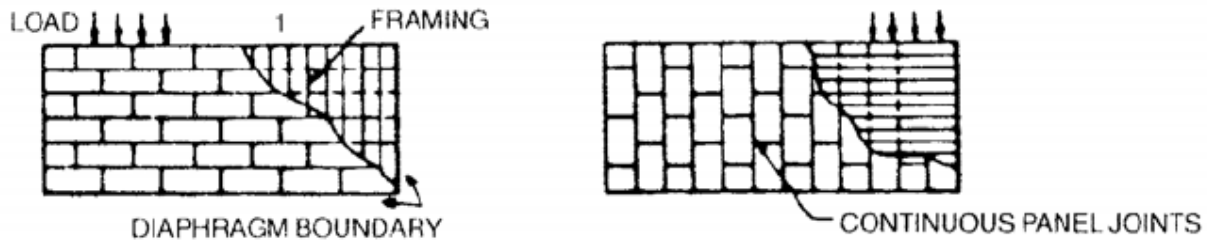

**TABLE 11—ALLOWABLE DIAPHRAGM SHEAR FOR WIND OR SEISMIC FORCES FOR ROOF DIAPHRAGMS
CONSISTING OF TECTUM III, IIIW, E OR TECTUM V PANELS, TECTUM I LONG-SPAN PLANK AND 3-INCH-THICK TECTUM I PLANK (plf)^{1,2,3}**

ITEM	SCREW SIZE	MINIMUM SCREW PENETRATION INTO FRAMING (inches)	PLANK THICKNESS (inches)	MAXIMUM SUPPORT SPACING (inches)	MINIMUM NORMAL WIDTH OF WOOD/STEEL FRAMING MEMBER (inches)	FIELD FASTENER SPACING (inches)	PERIMETER FASTENER SPACING (inches)	UNBLOCKED DIAPHRAGM ALLOWABLE SHEAR CAPACITY (plf)	SHEAR STIFFNESS, G_a (kips/in.)
Tectum III/E Panel	No. 14 self-tapping with 1½-inch-diameter steel washer	1 ⁴	5 MAX	96	Steel support only ⁵	16	12	310	90
Tectum III/E Panel	No. 14 self-tapping with 5/8-inch-diameter head	2	5 MAX	72	4	16	12	320	33
		2½	3½ MAX	60	4	16	12	360	42
		2½	3½ MAX	72	4	16	12	340	34
Tectum III/E ⁶ Panel with Overlay	No. 14 self-tapping with 1½-inch-diameter steel washer	1	5 MAX	72	4	8	6	785	52
Tectum IIIW Panel	7-inch by 14-Gage SIP Screw with 1½-inch washer	2	5 MAX	72	4	16	12	320	33
Tectum IIIW ⁶ Panel with Overlay	7-inch by 14-Gage SIP Screw with 1½-inch washer	2	5 MAX	72	4	8	6	785	52
Tectum V	W-11 Trufast	2	9	144	4	6	6	415	34
2-inch-thick Tectum I long-span plank ⁷	No. 14 with 2-inch-diameter washer	1¼	2	48	4	16	12	320	76
2½-inch-thick Tectum I long-span plank ⁷	No. 14 with 2-inch-diameter washer	1¼	2½	60	4	16	10	390	31
3-inch-thick Tectum I long-span plank ⁸	No. 14 with 2-inch-diameter washer	1½	3	72	4	16	12	280	16
3-inch-thick Tectum I plank	No. 11 with 2-inch-diameter washer	15/16 ⁴	3	48	Steel support only ⁵	10	10 ends 16 length	450	11

For **SI**: 1 inch = 25.4 mm, 1 plf = 14.6 N/m.

¹In addition to screw fastening, all boards must be fastened to one another at tongue-and-groove edge joints and to supports with a 3/8-inch-diameter bead of adhesive.

²The diaphragm length-to-width ratio for wood frame construction must not exceed 3:1. The panels are oriented to the load and framing as shown in Footnote 7 to Table 10.

³The diaphragm deflection may be calculated by using the equations in AWC SDPWS Section 4.2.2 or standard formulae in engineering references. When calculating deflection, both bending and shear deformations must be included. The tabulated shear stiffness, G_a , must be used in shear deformation calculation.

⁴Minimum penetration beyond the structural steel support.

⁵Minimum thickness of structural steel support must be 0.20 inch and the bearing length must be a minimum of 4 inches.

⁶An overlayment of 7/16-inch-thick-by-44-inch-wide-by-144-inch-long OSB must be attached to the top of the panels. Two-inch, No. 16 gauge staples at 4 inches on center spacing must be at the perimeter of each overlayment and at 8 inches on center spacing at 24 inch intervals. A 3/8-inch bead of adhesive must also be applied between the overlayment and the plank at the perimeter and at 24-inch intervals. All overlayment joints must be offset from panel joints.

⁷Long-span plank utilizes a 1½-inch-by-3/4-inch, No. 16 gauge steel channel section along the tongue-and-groove edges.

⁸Long-span plank utilizes a 5/8-inch-by-1½-inch, No. 16 gauge steel channel section along the tongue-and-groove edges.

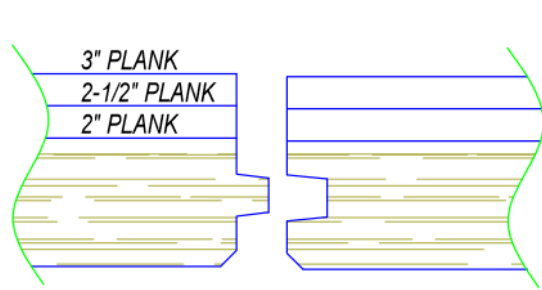

Tectum I Plank Edge Detail

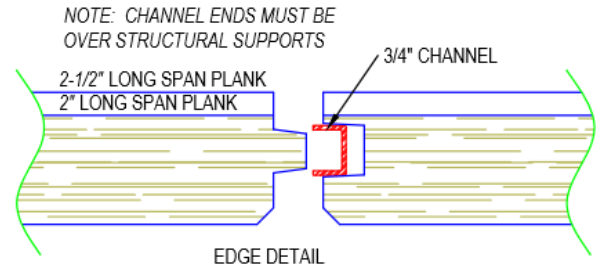

Tectum I Long Span Edge Detail

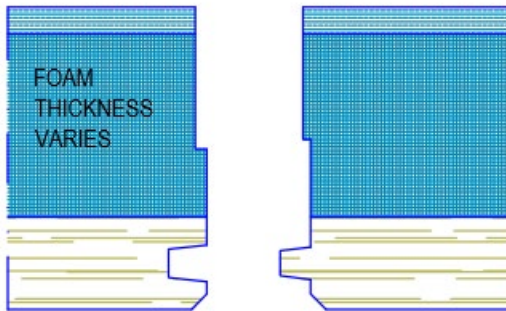

Tectum III/E Roof Plank Edge Detail

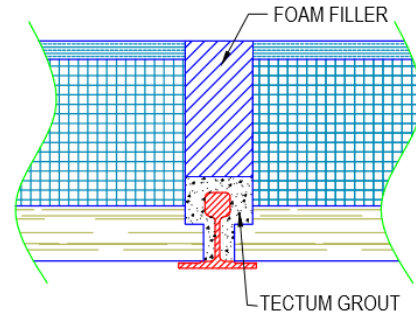

Tectum III/E Roof Tile Edge Detail

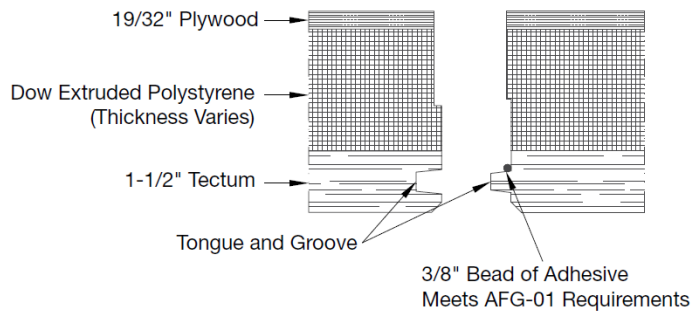

Tectum IIIW Panel Edge Detail

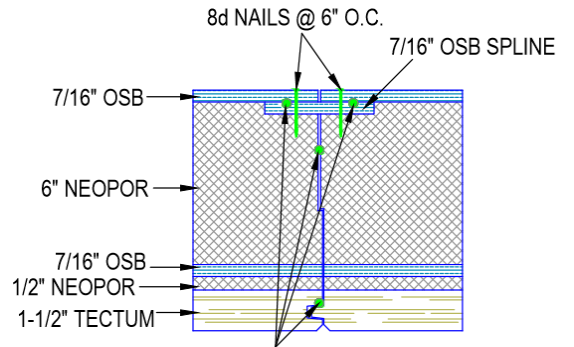

Tectum V Panel Edge Detail

FIGURE 1—TYPICAL EDGE DETAILS

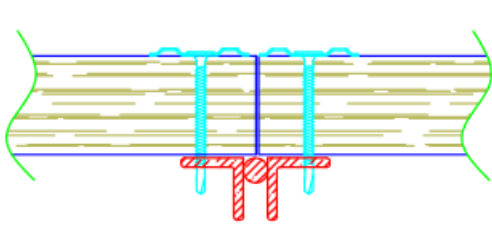

Tectum I Panel Typical End Condition on Steel

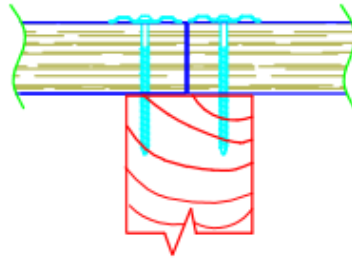

Tectum I Panel Typical End Condition on Wood

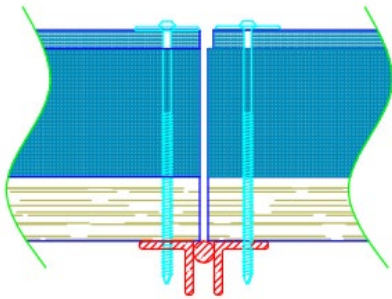

Tectum III/E Panel Typical End Condition on Steel

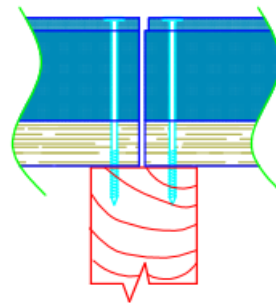

Tectum III/E Panel Typical End Condition on Wood

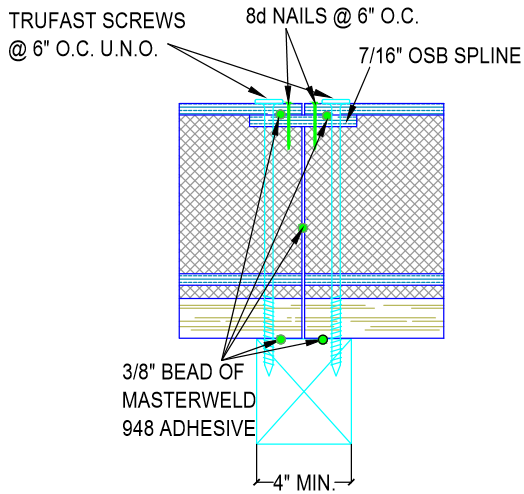

Tectum V Panel Typical End Condition on Wood

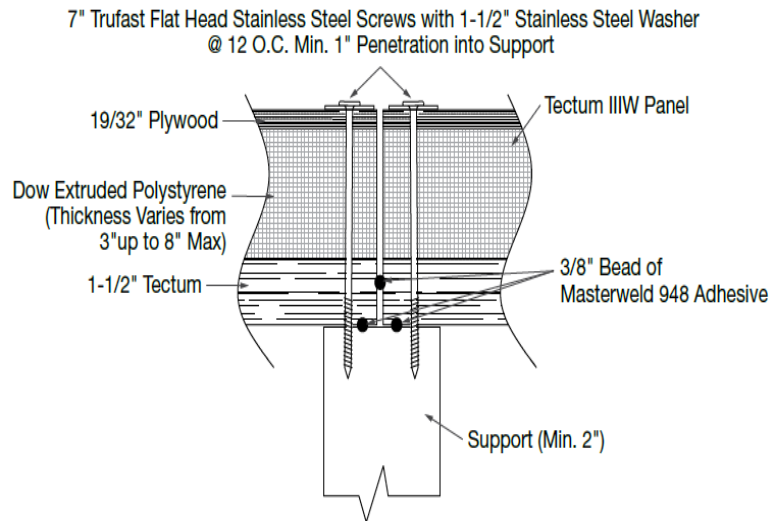

Tectum IIIW Panel Typical End Condition on Wood Support

FIGURE 2—TYPICAL END CONDITIONS

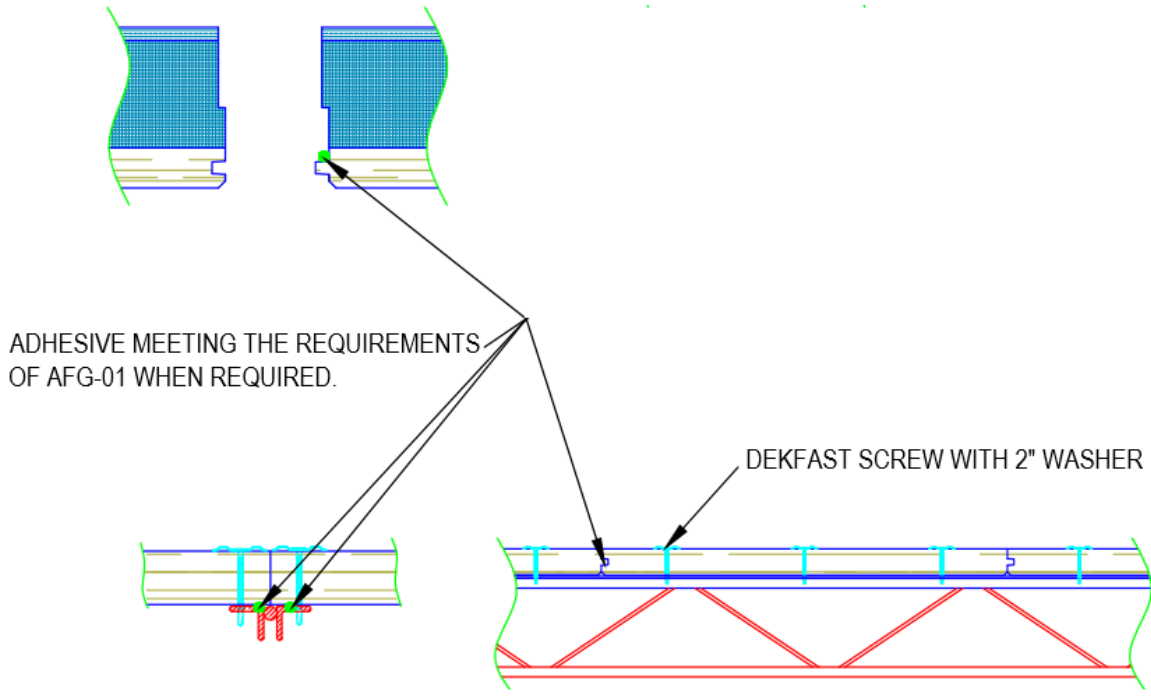

Tectum I Roof Deck Construction

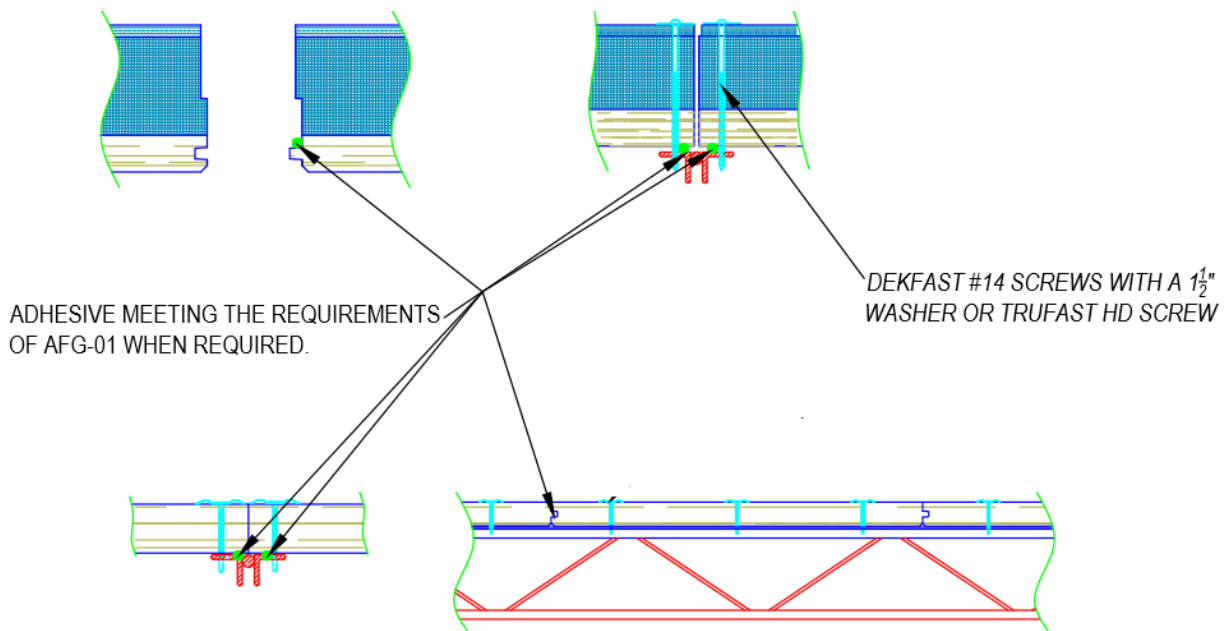

Tectum III, IIIW and E Roof Deck Construction

FIGURE 3—TYPICAL ROOF DECK CONSTRUCTIONS

DIVISION: 03 00 00—CONCRETE

Section: 03 51 13—Cementitious Wood Fiber Decks

DIVISION: 06 00 00—WOOD, PLASTICS AND COMPOSITES

Section: 06 12 00—Structural Panels

Section: 06 12 13—Cementitious Reinforced Panels

DIVISION: 09 00 00—FINISHES

Section: 09 84 00—Acoustic Room Components

REPORT HOLDER:

TECTUM, INC.

EVALUATION SUBJECT:

TECTUM I, TECTUM III, TECTUM IIIW, TECTUM E AND TECTUM V ROOF DECK PANELS

1.0 REPORT PURPOSE AND SCOPE

Purpose:

The purpose of this evaluation report supplement is to indicate that the Tectum I, III, IIIW, E, and V roof deck panels, described in ICC-ES evaluation report ESR-1112, have also been evaluated for compliance with the codes noted below.

Applicable code editions:

- 2022 California Building Code (CBC)

For evaluation of applicable chapters adopted by the California Office of Statewide Health Planning and Development (OSHPD) AKA: California Department of Health Care Access and Information (HCAI) and the Division of the State Architect (DSA), see Sections 2.1.1 and 2.1.2 below.

2.0 CONCLUSIONS

2.1 CBC

The Tectum I, III, IIIW, E, and V roof deck panels, described in Sections 2.0 through 7.0 of the evaluation report ESR-1112, comply with CBC Chapters 23 and 26, provided the design and installation are in accordance with the 2021 *International Building Code*® (IBC) provisions noted in the evaluation report and the additional requirements of the CBC Chapters 3, 8, 23 and 26, as applicable.

The products have not been evaluated under Chapter 7A for use in the exterior design and construction of new buildings located in a Fire Hazard Severity Zone within State Responsibility Areas or any Wildland–Urban Interface Fire Area.

2.1.1 OSHPD:

The applicable OSHPD Sections and Chapters of the CBC are beyond the scope of this supplement.

2.1.2 DSA:

The applicable DSA Sections and Chapters of the CBC are beyond the scope of this supplement.

The products described in this supplement have not been evaluated for compliance with the *International Wildland–Urban Interface Code*®.

This supplement expires concurrently with the evaluation report ESR-1112, reissued May 2024.

DIVISION: 03 00 00—CONCRETE

Section: 03 51 13—Cementitious Wood Fiber Decks

DIVISION: 06 00 00—WOOD, PLASTICS AND COMPOSITES

Section : 06 12 00—Structural Panels

Section: 06 12 13—Cementitious Reinforced Panels

DIVISION: 09 00 00—FINISHES

Section: 09 84 00—Acoustic Room Components

REPORT HOLDER:

TECTUM, INC.

EVALUATION SUBJECT:

TECTUM I, TECTUM III, ECTUM IIIW, TECTUM E AND TECTUM V ROOF DECK PANELS

1.0 REPORT PURPOSE AND SCOPE**Purpose:**

The purpose of this evaluation report supplement is to indicate that Tectum I, Tectum III, Tectum IIIW, Tectum E and Tectum V panels addressed in ICC-ES evaluation report ESR-1112, have also been evaluated for compliance with the codes noted below.

Applicable code editions:

- 2023 *Florida Building Code—Building*

2.0 CONCLUSIONS

The Tectum I, Tectum III, Tectum IIIW, Tectum E and Tectum V panels, described in Sections 2.0 through 7.0 of ICC-ES evaluation report ESR-1112, comply with the *Florida Building Code-Building*. The design requirements must be determined in accordance with the *Florida Building Code-Building*. The installation requirements noted in ICC-ES evaluation report ESR-1112 for the 2021 *International Building Code*® meet the requirements of the *Florida Building Code-Building*.

Use of the Tectum I, Tectum III, Tectum IIIW, Tectum E and Tectum V panels for compliance with the High-Velocity Hurricane Zone provisions of the *Florida Building Code-Building* has not been evaluated and is outside the scope of this supplemental report.

For products falling under Florida Rule 61G20-3, verification that the report holder's quality assurance program is audited by a quality assurance entity approved by the Florida Building Commission for the type of inspections being conducted is the responsibility of an approved validation entity (or the code official when the report holder does not possess an approval by the Commission).

This supplement expires concurrently with the evaluation report reissued May 2024.