



ICC-ES Listing Report

Reissued October 2024

ESL-1280

This listing is subject to renewal October 2025.

CSI: DIVISION: 03 00 00—CONCRETE
Section: 03 16 00—Concrete Anchors

DIVISION: 05 00 00—METALS
Section 05 05 19—Post Installed Concrete Anchors

Product Certification System:

The ICC-ES product-certification system includes evaluating evidence in support of test data provided by the listee to verify compliance with applicable codes and standards. The system also involves factory inspections, and assessment and surveillance of the listee's quality system.

Product: SUP-R-BOLT CONCRETE SCREW ANCHORS

Listee: MKT FASTENING, LLC

Evaluation: The product SUP-R-BOLT CONCRETE SCREW ANCHORS are carbon steel and heat-treated post-installed mechanical anchors comprised of a body with a hex washer as illustrated in Figure 1 of this listing, and evaluated in accordance with the following standards:

- ASTM E488-15, Test Methods for Strength of Anchors in Concrete and Masonry Elements, ASTM International.

Findings: The SUP-R-BOLT CONCRETE SCREW ANCHORS have the ultimate load for single anchor in cracked and uncracked concrete as specified in Table 1 of this listing.

Identification:

1. Anchors are packaged in containers labeled with the company logo and name (MKT Fastening, LLC) product name, anchor size and length, catalog number and the evaluation report number ([ESR-4347](#)) and/or the ICC-ES Listing Report number (ESL-1280), and when applicable, the ICC-ES Listing Mark.
2. The report holder's contact information is the following:
MKT FASTENING, LLC
1 GUNNEBO DRIVE
LONOKE, ARKANSAS 72086
(501) 676 -2222
www.mktfastening.com

Installation: Each anchor must be installed in accordance with the MK Fastening, LLC published installation instructions. The minimum embedment, concrete requirements and installation parameters must comply with Table 1 and Figure 2.

Conditions of listing:

1. The listing addresses only conformance with the standards and code sections noted above.
2. Approval of the product's use is the sole responsibility of the local code official.
3. The listing applies only to the materials tested and as submitted for review by ICC-ES.
4. The mean ultimate loads listed in Table 1 are not intended to be used as design values; results of reliability and service-condition tests have not been included in the listing.

TABLE 1—DATA FOR SUP-R-BOLT CONCRETE SCREW ANCHORS FOR USE IN CONCRETE

Characteristic	Symbol	Unit	Nominal Anchor Diameter							
			3/8 inch		1/2 inch		5/8 inch		3/4 inch	
Drill Bit Diameter	d_o	in (mm)	3/8 (9.5)	3/8 (9.5)	1/2 (12.7)	1/2 (12.7)	5/8 (15.9)	5/8 (15.9)	3/4 (19.1)	3/4 (19.1)
Nominal Embedment Depth	h_{nom}	in (mm)	2 1/2 (64)	3 1/4 (83)	3 (76)	4 1/4 (108)	3 1/4 (83)	5 (127)	4 (102)	6 1/4 (159)
Effective Embedment Depth	h_{ef}	in (mm)	1.85 (47)	2.49 (63)	2.21 (56)	3.27 (83)	2.36 (60)	3.85 (98)	2.97 (75)	4.89 (124)
Minimum Hole Depth	h_{hole}	in (mm)	2 3/4 (70)	3 1/2 (89)	3 3/8 (86)	4 5/8 (117)	3 5/8 (92)	5 3/8 (137)	4 3/8 (111)	6 5/8 (168)
Fixture Hole Diameter	d_f	in (mm)	1/2 (12.7)		5/8 (15.9)		3/4 (19.1)		7/8 (22.2)	
Maximum Installation Torque	$T_{inst,max}$	ft.lb (Nm)	35 (47)	50 (68)	45 (61)	65 (88)	85 (115)	100 (136)	115 (156)	150 (203)
Maximum impact wrench torque rating	$T_{impact,max}$	ft lb (Nm)	380 (515)	380 (515)	380 (515)	380 (515)	380 (515)	380 (515)	380 (515)	380 (515)
Minimum Concrete Thickness	h_{min}	in (mm)	4 (102)	4 3/4 (121)	4 3/4 (121)	6 3/4 (171)	5 (127)	7 (178)	6 (152)	8 1/8 (206)
Critical Edge Distance	c_{ac}	in (mm)	4 (102)	5 (127)	4 1/2 (114)	5 (127)	3 3/4 (95)	7 (178)	4 1/2 (114)	8 (203)
Mean Ultimate Load From Static Tests ⁷	Symbol	Units	Nominal Anchor Diameter							
			3/8 inch		1/2 inch		5/8 inch		3/4 inch	
Mean ultimate static tensile load, uncracked low-strength normal-weight concrete	F_m	lb.	6,089 ²	10,122 ²	7,840 ²	13,035 ²	6,052 ¹	17,530 ¹	10,543 ²	19,626 ¹
Mean ultimate static tensile load, uncracked high-strength normal-weight concrete	F_m	lb.	7,323 ⁵	12,708 ⁵	9,628 ⁵	17,080 ⁵	11,130 ⁵	21,432 ⁴	16,146 ⁵	33,711 ⁴
Mean ultimate static tensile load, cracked low-strength normal-weight concrete ⁶	F_m	lb.	3,697 ¹	5,572 ¹	5,357 ¹	8,552 ¹	5,399 ²	10,684 ¹	7,815 ¹	18,142 ²
Mean ultimate static tensile load, cracked high-strength normal-weight concrete ⁶	F_m	lb.	5,255 ⁴	7,751 ⁴	7,368 ⁴	11,580 ⁴	7,506 ⁴	15,868 ⁴	11,325 ⁴	22,243 ⁴

For SI: 1 in = 25.4 mm, 1 in² = 6.451×10⁻⁴ m, 1 ft-lb = 1.356 Nm, 1 lb/in² = 6.895 Pa.

¹ Tabulated values are adjusted to $f_c = 3,000$ psi.

² Tabulated values are adjusted to $f_c = 3,500$ psi.

³ Tabulated values are adjusted to $f_c = 7,000$ psi.

⁴ Tabulated values are adjusted to $f_c = 7,500$ psi.

⁵ Tabulated values are adjusted to $f_c = 8,000$ psi.

⁶ Static tensile tests with crack-opening width of 0.012 inch (0.3 mm).

⁷ Mean ultimate loads with no safety factors applied differ from, and are higher than, the characteristic capacity as defined in ACI 318, ACI 355.2 and ACI 193. Characteristic capacities for design in accordance with ACI 318 must include assessment of reliability and service condition tests, design information for concrete breakout and steel capacity, and applicable strength reduction factors.

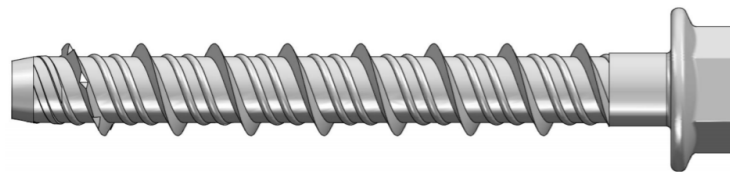

FIGURE 1—SUP-R-BOLT CONCRETE SCREW ANCHOR

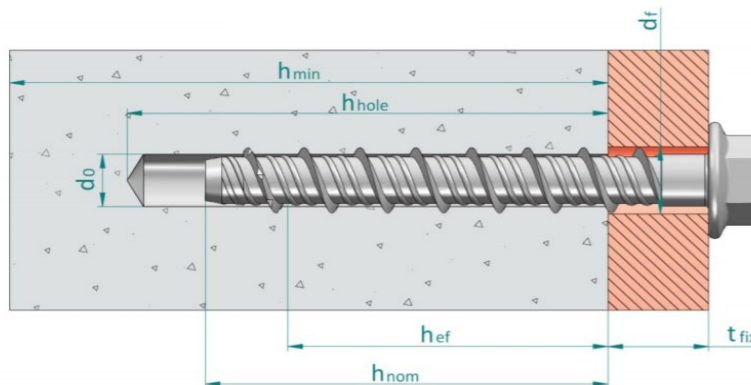

FIGURE 2—SUP-R-BOLT CONCRETE SCREW ANCHOR INSTALLATION