



## ICC-ES Listing Report ESL-1191

Reissued November 2023

Revised January 2024

This listing is subject to renewal November 2024.

**CSI:** DIVISION: 07 00 00—THERMAL AND MOISTURE PROTECTION  
Section: 07 81 23—Intumescent Fireproofing  
  
DIVISION: 09 00 00—FINISHES  
Section: 09 96 46—Intumescent Painting

### Product Certification System:

The ICC-ES product-certification system includes evaluating reports of tests of standard manufactured product, prepared by accredited testing laboratories and provided by the listee, to verify compliance with applicable codes and standards. The system also involves factory inspections, and assessment and surveillance of the listee's quality system.

**Product:** FLAMEOFF® FIRE BARRIER PAINT

**Listee:** FLAMEOFF COATINGS, INC.

**Evaluation:** FlameOff® Fire Barrier Paint is a water-based intumescent coating and was evaluated based on a tested wood framed non-load bearing wall assembly, non-load bearing structural steel columns, and structural steel W-shape beams (3-sided exposure) consisting of building-material components described in the Design Listings, tested in accordance with the following standards:

- ASTM E119-18B, ASTM E119-16 and ASTM E119-12A, Standard Test Methods for Fire Tests of Building Construction and Materials, ASTM International.
- UL 263-11 (with revisions through March 2018), UL 263-11 (with revisions through June 2015) and UL 263-11, Standard for Fire Tests of Building Construction and Materials, Underwriters Laboratories, Inc.
- CAN/ULC-S101-14, Standard Methods of Fire Endurance Tests of Building Construction and Materials, ULC Standards.

**Findings:** FlameOff® Fire Barrier Paint, as a component of the assembly described in each ICC Design Listing, has met the performance criteria in accordance with ASTM E119/CAN/ULC-S101, and as referenced in the applicable sections of the following code editions:

- 2021, 2018 and 2015 *International Building Code*®  
Applicable Section: 703.2
- *National Building Code of Canada*® 2015  
Applicable Section: Volume 1- Division B: Section 3.1.7.

### Identification:

1. The ICC-ES mark of conformity, electronic labeling, or the listing report number (ICC-ES ESL-1191), and when applicable, the ICC-ES listing mark, along with the name, registered trademark, or registered logo of the report holder must be included in the product label.
2. In addition, containers of the intumescent material bear the company name (FlameOff Coatings, Inc.) and address, product name (FlameOff® Fire Barrier Paint), storage and shelf-life information.

3. The report holder's contact information is the following:

**FLAMEOFF COATINGS, INC.**  
**3915 BERYL ROAD, SUITE 130**  
**RALEIGH, NORTH CAROLINA 27607**  
**(888) 816-7468**  
[www.flameoffcoatings.com](http://www.flameoffcoatings.com)

**Installation:** The FlameOff® Fire Barrier Paint shall be installed in accordance with FlameOff Coatings, Inc.'s published installation instructions and applicable codes.

**Conditions of Listing:**

1. Additional attributes and their applications can be found in the ICC-ES Evaluation Report, [ESR-3874](#).
2. The listing report addresses only conformance with the standards and code sections noted above.
3. Approval of the product's use is the sole responsibility of the local code official.
4. The listing report applies only to the materials tested and as submitted for review by ICC-ES.
5. The FlameOff® Fire Barrier Paint described in this listing report is produced under a quality control program with inspections by ICC-ES.

**Applicant:** FLAMEOFF COATINGS, INC.  
**Product:** FLAMEOFF® FIRE BARRIER PAINT  
**Standard:** ASTM E119 (UL 263) / CAN/ULC-S101  
**Assembly Rating:** 2-Hour (Nonsymmetric Wood Stud Wall Assembly)  
**Load:** Non-Load Bearing

**Assembly:**

*IFRM = Intumescent Fire-Resistive Materials*

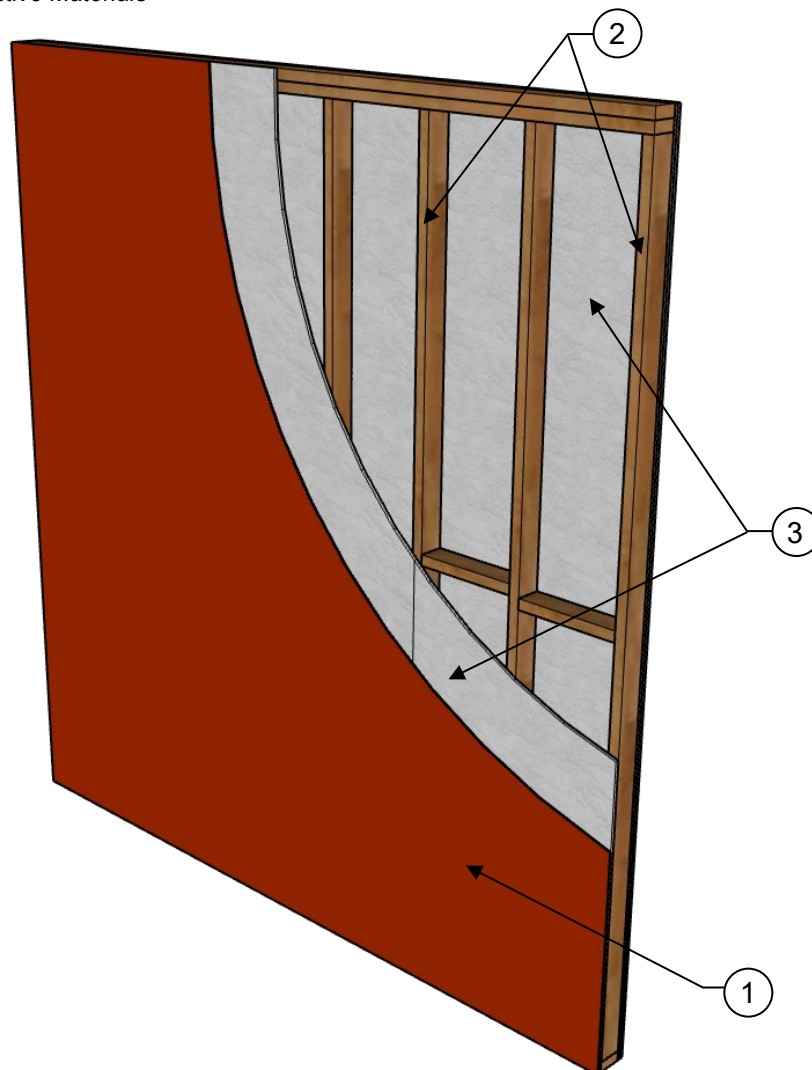

**COMPONENTS OF CONSTRUCTION:**

1. **FlameOff® Fire Barrier Paint** – Applied to the exposed face of the wall assembly in accordance with manufacturer's instructions to the minimum dry film thickness of 43 mils (1.09 mm).
2. **Wood Framing** – Nominal 2-inch by 4-inch (50.8 mm x 101.6 mm) wood studs. Top and bottom bearing plates [nominal 2-inch by 4-inch (50.8 mm x 101.6 mm) wood studs laid flatwise] were cut to 120-inch (3048 mm) lengths. One stud was centered along the vertical centerline of the assembly and all studs were spaced 16 inches (406.4 mm) on center from the vertical centerline. The end studs were spaced 12 inches (304.8 mm) on center. At each stud and bearing plate connection, two 3½-inch (88.9 mm) long 16d nails were used. Nominal 2-inch by 4-inch (50.8 mm x 101.6mm) blocking were installed in between the studs along the horizontal centerline of the wall assembly. The blocking was staggered to allow two 3½-inch (88.9 mm) long 16d nails to be driven from either side of each section of blocking. Maximum height of the wall assembly was 115.5 inches (2933.7 mm).
3. **Gypsum Wallboard** – Nominal 5/8-inch (15.9 mm) thick Type X gypsum wallboard by United States Gypsum Company, which was applied vertically to the wood studs on both sides of the wall assembly. The exposed face has one layer of gypsum wallboard while the unexposed face of the wall assembly had two layers of gypsum wallboard. The first layer (both exposed and unexposed) of gypsum wallboard was fastened to the wood framing using 1¼-inch (31.8 mm) long Type W screws spaced 8 inches (203.2 mm) on center along the perimeter and in the field; and the second layer on the unexposed side was fastened with 2-inch long (50.8 mm) Type W screws spaced 8 inches (203.2 mm) on center along the perimeter and in the field. The vertical gypsum wallboard joints between layers of the unexposed face were staggered one stud cavity while the vertical joints were also staggered across stud cavities. All gypsum wallboard joints and screws received a Level 2 finish complying with ASTM C840 or GA216.

**Applicant:** FLAMEOFF COATINGS, INC.

**Product:** FLAMEOFF® FIRE BARRIER PAINT

**Standard:** ASTM E119 (UL 263) / CAN/ULC-S101

**Structural Shape:** W-shape (H-section or I-section) Columns

*IFRM = Intumescent Fire-Resistive Materials*

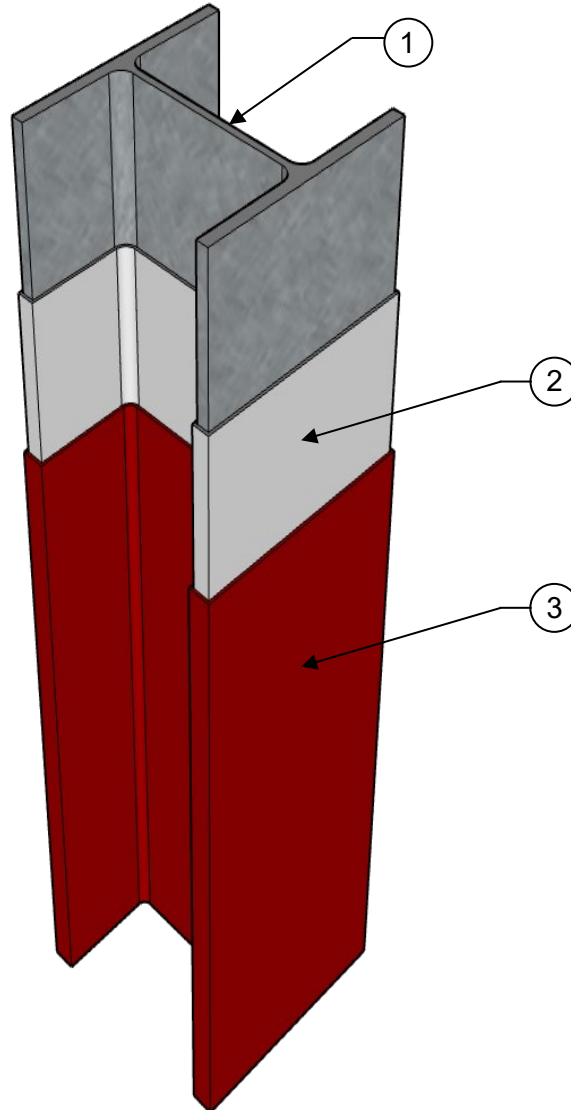

**COMPONENTS OF CONSTRUCTION:**

1. **Structural Steel Column** – Wide flange steel columns (H-section or I-section) with Hp/A or W/D section factors based on exposure on four sides. Columns shall be free of dirt, loose scale, and oil before application of metal alkyd primer.
2. **Primer Coating** – Structural steel to be primed with a layer of an alkyd metal primer with an average applied dry film thickness of 3.7 mils (0.09 mm). Primed surface should be cleaned, dried, and free of dirt, loose scale, grease, oil, and any contaminant that would inhibit bonding of the FlameOff® Barrier Paint to the primer.
3. **FlameOff® Fire Barrier Paint** – Coating applied in accordance with manufacturer's instructions to the minimum dry film thicknesses shown in IFRM-1191-02 Table 1, based on the column section factor and fire resistance period. Coating thicknesses may be interpolated between section factors at the same fire resistance period. Extrapolation beyond the minimum and maximum section factors and fire resistance periods is not permitted.

IFRM-1191-02 TABLE 1 – MINIMUM COATING THICKNESS FOR A W-SHAPE (H- OR I-SECTION) COLUMN SECTION FACTOR TO ACHIEVE ESTIMATED FIRE RESISTANCE PERIOD

Section Factor		Fire Resistance Period (min)					
Hp/A (m <sup>-1</sup> )	W/D (lbs./in)	60		90		120	
		Thickness in mm (mils)					
70	1.91	0.8	(32)	1.5	(58)	2.1	(81)
75	1.79	0.8	(32)	1.5	(58)	2.2	(86)
80	1.67	0.8	(32)	1.5	(58)	2.3	(91)
85	1.58	0.8	(32)	1.6	(61)	2.4	(96)
90	1.49	0.8	(32)	1.6	(64)	2.6	(101)
95	1.41	0.8	(32)	1.7	(68)	2.7	(106)
100	1.34	0.8	(32)	1.8	(71)	2.8	(112)
105	1.28	0.8	(32)	1.9	(74)	3.0	(117)
110	1.22	0.9	(34)	2.0	(77)	3.1	(122)
115	1.16	0.9	(35)	2.0	(81)	3.2	(127)
120	1.12	0.9	(37)	2.1	(84)	3.4	(132)
125	1.07	1.0	(39)	2.2	(87)	3.5	(137)
130	1.03	1.0	(41)	2.3	(91)	3.6	(142)
135	0.99	1.1	(42)	2.4	(94)	3.7	(148)
140	0.96	1.1	(44)	2.5	(97)	3.9	(153)
145	0.92	1.2	(46)	2.5	(100)	4.0	(158)
150	0.89	1.2	(48)	2.6	(104)	4.1	(163)
155	0.86	1.3	(50)	2.7	(107)	4.3	(168)
160	0.84	1.3	(51)	2.8	(110)	4.4	(173)
165	0.81	1.3	(52)	2.9	(113)	4.5	(178)
170	0.79	1.3	(53)	3.0	(117)	4.7	(184)
175	0.77	1.4	(53)	3.0	(120)	4.8	(189)
180	0.74	1.4	(54)	3.1	(123)	4.9	(194)
185	0.72	1.4	(55)	3.2	(126)	5.0	(199)
190	0.71	1.4	(56)	3.3	(129)	5.2	(204)
195	0.69	1.4	(56)	3.4	(133)	5.3	(209)
200	0.67	1.5	(58)	3.4	(136)	5.4	(214)
205	0.65	1.5	(60)	3.5	(139)	5.6	(219)
210	0.64	1.6	(61)	3.6	(142)	5.7	(224)
215	0.62	1.6	(63)	3.7	(145)	5.8	(229)
220	0.61	1.7	(65)	3.8	(148)	5.9	(233)
225	0.60	1.7	(67)	3.8	(151)	6.1	(238)
230	0.58	1.7	(69)	3.9	(155)	6.2	(243)
235	0.57	1.8	(71)	4.0	(158)	6.3	(248)
240	0.56	1.8	(73)	4.1	(161)	6.4	(253)
245	0.55	1.9	(74)	4.2	(164)	6.5	(258)
250	0.54	1.9	(76)	4.2	(167)	6.7	(263)
255	0.53	2.0	(78)	4.3	(170)	6.8	(267)
260	0.52	2.0	(80)	4.4	(173)	6.9	(272)
265	0.51	2.1	(82)	4.5	(179)	7.1	(281)
270	0.50	2.1	(84)	4.7	(184)	7.4	(290)
275	0.49	2.2	(86)	4.8	(190)	7.6	(299)
280	0.48	2.2	(87)	5.0	(196)	7.8	(308)
285	0.47	2.3	(89)	5.1	(201)	8.1	(317)
290	0.46	2.3	(91)	5.3	(207)	-	( - )
295	0.45	2.4	(93)	5.4	(213)	-	( - )
300	0.45	2.4	(95)	5.6	(219)	-	( - )
305	0.44	2.5	(97)	5.7	(224)	-	( - )

For SI: 1 inch = 25.4 mm

Footnote: Empty cells (“-”) indicate unknown performance of coating thickness.

**Applicant:** FLAMEOFF COATINGS, INC.  
**Product:** FLAMEOFF® FIRE BARRIER PAINT  
**Standard:** ASTM E119 (UL 263) / CAN/ULC-S101  
**Structural Shape:** Steel Tube and Pipe Columns  
*IFRM = Intumescent Fire-Resistive Materials*

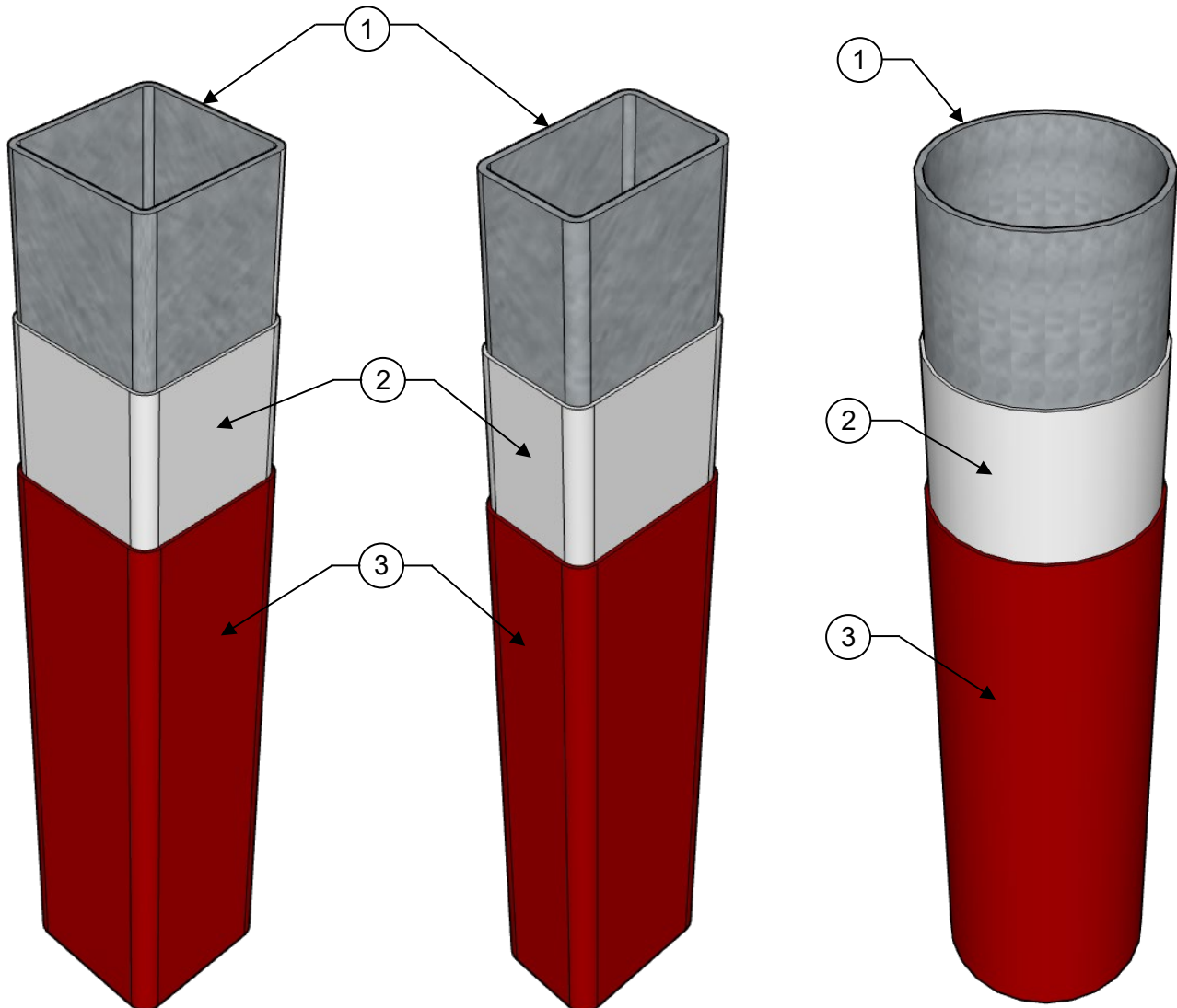

Listings are not to be construed as representing aesthetics or any other attributes not specifically addressed, nor are they to be construed as an endorsement of the subject of the listing or a recommendation for its use. There is no warranty by ICC Evaluation Service, LLC, express or implied, as to any finding or other matter in this listing, or as to any product covered by the listing.



**COMPONENTS OF CONSTRUCTION:**

1. **Structural Steel Column** – Square tube, rectangular tube, or circular pipe steel columns with Hp/A or A/P section factors based on exposure on four sides. Columns shall be free of dirt, loose scale, and oil before application of metal alkyd primer.
2. **Primer Coating** – Structural steel to be primed with a layer of an alkyd metal primer with an average applied dry film thickness of 3.7 mils (0.09 mm). Primed surface shall be cleaned, dried, and free of dirt, loose scale, grease, oil, and any contaminant that would inhibit bonding of the FlameOff® Barrier Paint to the primer.
3. **FlameOff® Fire Barrier Paint** – Coating applied in accordance with manufacturer's instructions to the minimum dry film thicknesses shown in IFRM-1191-03 Table 1, based on the column section factor and fire resistance period. Coating thicknesses may be interpolated between section factors at the same fire resistance period. Extrapolation beyond the minimum and maximum section factors and fire resistance periods is not permitted.

**IFRM-1191-03 TABLE 1 – MINIMUM COATING THICKNESS FOR A STEEL TUBE OR PIPE COLUMN SECTION FACTOR TO ACHIEVE ESTIMATED FIRE RESISTANCE PERIOD**

Section Factor		Fire Resistance Period (min)							
Hp/A (m <sup>-1</sup> )	A/P (in)	45		60		90		120	
		Thickness in mm (mils)							
80	0.49	0.7	(29)	1.5	(60)	3.1	(123)	4.7	(185)
85	0.46	0.8	(30)	1.6	(62)	3.2	(127)	4.9	(192)
90	0.44	0.8	(31)	1.6	(64)	3.3	(132)	5.1	(199)
95	0.41	0.8	(32)	1.7	(67)	3.5	(136)	5.2	(206)
100	0.39	0.8	(33)	1.7	(69)	3.6	(140)	5.4	(212)
105	0.37	0.9	(34)	1.8	(70)	3.7	(144)	5.5	(218)
110	0.36	0.9	(35)	1.8	(72)	3.8	(148)	5.7	(226)
115	0.34	0.9	(35)	1.9	(74)	3.8	(152)	5.9	(234)
120	0.33	0.9	(36)	1.9	(76)	3.9	(155)	6.1	(242)
125	0.31	0.9	(37)	2.0	(77)	4.0	(158)	6.3	(250)
130	0.30	1.0	(38)	2.0	(79)	4.1	(162)	6.5	(258)
135	0.29	1.0	(41)	2.1	(82)	4.4	(174)	6.7	(266)
140	0.28	1.1	(45)	2.1	(84)	4.5	(179)	6.9	(274)
145	0.27	1.2	(48)	2.2	(87)	4.7	(184)	7.2	(282)
150	0.26	1.3	(52)	2.3	(89)	4.8	(189)	7.4	(290)
155	0.25	1.4	(56)	2.3	(92)	4.9	(195)	7.6	(297)
160	0.25	1.5	(59)	2.4	(95)	5.1	(200)	7.8	(305)
165	0.24	1.6	(63)	2.5	(97)	5.2	(205)	8.0	(313)
170	0.23	1.7	(66)	2.5	(100)	5.3	(211)	8.2	(321)
175	0.22	1.8	(70)	2.6	(102)	5.5	(216)	8.4	(329)
180	0.22	1.9	(74)	2.7	(105)	5.6	(221)	8.6	(337)
185	0.21	2.0	(77)	2.7	(108)	5.8	(226)	8.8	(345)

For SI: 1 inch = 25.4 mm

Footnote: Empty cells (“-”) indicate unknown performance of coating thickness.

**Applicant:** FLAMEOFF COATINGS, INC.  
**Product:** FLAMEOFF® FIRE BARRIER PAINT  
**Standard:** ASTM E119 (UL 263) / CAN/ULC-S101  
**Structural Shape:** W-Shape (H-section or I-section) Beams  
*IFRM = Intumescent Fire-Resistive Materials*

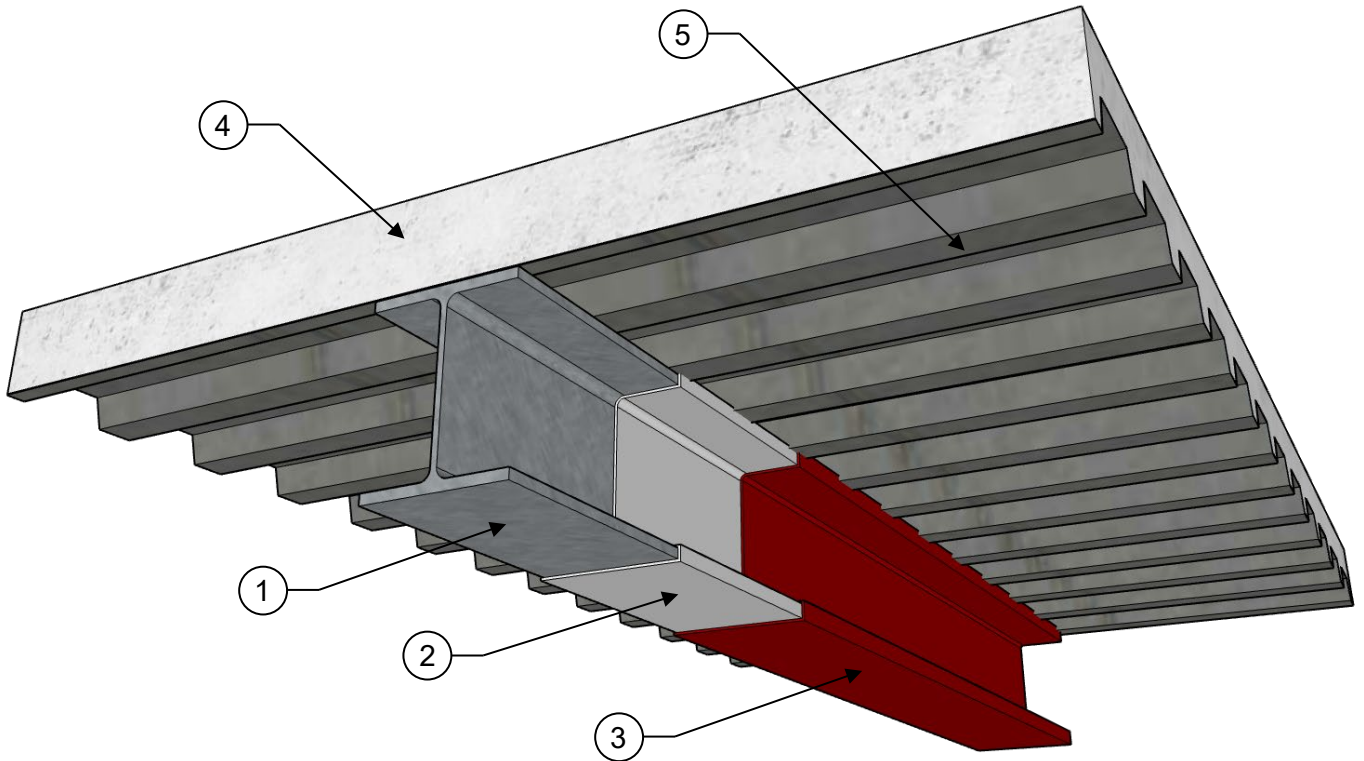

**COMPONENTS OF CONSTRUCTION:**

- Structural Steel Beams** – Wide flange steel beams (H-section or I-section) with Hp/A or W/D section factors based on exposure on three sides. Beams shall be free of dirt, loose scale, and oil before application of metal alkyd primer.
- Primer Coating** – Structural steel to be primed with a layer of an alkyd metal primer with an average applied dry film thickness of 3.1 mils (0.08 mm). Primed surface shall be cleaned, dried, and free of dirt, loose scale, grease, oil, and any contaminant that would inhibit bonding of the FlameOff® Barrier Paint to the primer.
- FlameOff® Fire Barrier Paint** – Coating applied in accordance with manufacturer's instructions to the minimum dry film thicknesses shown in IFRM-1191-04 Tables 1 and 2 based on the beam section factor (exposure on three sides) and fire resistance period. Coating thicknesses may be interpolated between section factors at the same fire resistance period. Extrapolation beyond the minimum and maximum section factors and fire resistance periods is not permitted.
- Concrete** – Minimum thickness over the steel deck and form unit crests must be 2½-inch-thick (63.5 mm) and have a minimum 3,000 psi (20.7 MPa) compressive strength and unit weight of  $145 \pm 3$  pcf ( $2323 \pm 48$  kg/m<sup>3</sup>).
- Steel Deck or Floor Units** – Minimum 2-inch (50.8 mm) deep galvanized fluted units with a nominal thickness of 0.039-inch (0.99 mm); welded to the structural steel beam.
- Shear Stud Connectors (Not Shown)** – (Optional) Headed type or equivalent per AISC Specification. Connectors must be welded to the top flange of the structural steel beam through the steel decking. Studs shall be designed and installed in accordance with AISC guidelines to provide composite action (between structural steel beam and concrete deck), as required.
- Mineral Wool Insulation (Not Shown)** – Flute spaces between the structural steel beam and the steel deck shall be completely filled with mineral wool insulation having a minimum density of 6.15 pcf (98.5 kg/m<sup>3</sup>).

**IFRM-1191-04 TABLE 1 – MINIMUM COATING THICKNESS FOR A W-SHAPE (H- OR I-SECTION) BEAM SECTION FACTOR TO ACHIEVE ESTIMATED FIRE RESISTANCE PERIOD (UNRESTRAINED BEAM RATING).<sup>1, 2</sup>**

Unrestrained Beam Rating					
Section Factor		Fire Resistance Period (min)			
Hp/A (m <sup>-1</sup> )	W/D (lbs./in)	60		90	
		Thickness in mm (mils)			
70	1.91	1.19	(46.8)	1.84	(72.5)
80	1.67	1.19	(46.8)	1.84	(72.5)
90	1.49	1.19	(46.8)	1.84	(72.5)
100	1.34	1.25	(49.3)	1.95	(76.7)
110	1.22	1.31	(51.7)	2.05	(80.8)
120	1.12	1.37	(54.1)	2.16	(84.9)
130	1.03	1.44	(56.5)	2.26	(89.0)
140	0.96	1.50	(58.9)	2.37	(93.1)
150	0.89	1.56	(61.3)	2.47	(97.2)
160	0.84	1.62	(63.7)	2.57	(101.3)
168	0.80	1.67	(65.7)	2.66	(104.6)
170	0.79	1.68	(66.2)	2.68	(105.5)
180	0.74	1.74	(68.6)	2.78	(109.6)
190	0.71	1.80	(71.0)	2.89	(113.7)
194	0.69	1.83	(72.0)	2.93	(115.3)
200	0.67	1.86	(73.4)	-	( - )
210	0.64	1.93	(75.8)	-	( - )
220	0.61	1.99	(78.2)	-	( - )
230	0.58	2.05	(80.7)	-	( - )
240	0.56	2.11	(83.1)	-	( - )
250	0.54	2.17	(85.5)	-	( - )

For SI: 1 inch = 25.4 mm, 1 inch = 1000 mils

Footnotes:

<sup>1</sup> Empty cells (“-”) indicate unknown performance of coating thickness.

<sup>2</sup> The design loads used for testing the steel beam assemblies are based on the worst-case flexural design load of the structural steel beam in accordance with AISC (Specification for Structural Steel Buildings), unless noted otherwise. Both Allowable Strength Design (ASD) and Load and Resistance Factor Design (LRFD) methods were considered.

**IFRM-1191-04 TABLE 2 – MINIMUM COATING THICKNESS FOR A W-SHAPE (H- OR I-SECTION) BEAM SECTION FACTOR TO ACHIEVE ESTIMATED FIRE RESISTANCE PERIOD (RESTRAINED BEAM RATING).<sup>1, 2</sup>**

Section Factor		Restrained Beam Rating					
Hp/A (m <sup>-1</sup> )	W/D (lbs./in)	Fire Resistance Period (min)					
		60		90		120	
		Thickness in mm (mils)					
70	1.91	0.97	(38.2)	1.36	(53.6)	2.32	(91.2)
80	1.67	0.97	(38.2)	1.36	(53.6)	2.32	(91.2)
90	1.49	0.97	(38.2)	1.36	(53.6)	2.32	(91.2)
100	1.34	1.03	(40.6)	1.42	(56.0)	2.38	(93.6)
110	1.22	1.09	(43.0)	1.48	(58.5)	2.44	(96.0)
120	1.12	1.15	(45.5)	1.55	(60.9)	2.50	(98.4)
130	1.03	1.22	(47.9)	1.61	(63.3)	2.56	(100.8)
140	0.96	1.28	(50.3)	1.67	(65.7)	2.62	(103.2)
150	0.89	1.34	(52.7)	1.73	(68.1)	2.68	(105.7)
160	0.84	1.40	(55.1)	1.79	(70.5)	2.74	(108.1)
168	0.80	1.45	(57.1)	1.84	(72.5)	2.79	(110.0)
170	0.79	1.46	(57.5)	1.85	(72.9)	-	( - )
180	0.74	1.52	(60.0)	1.91	(75.4)	-	( - )
190	0.71	1.58	(62.4)	1.98	(77.8)	-	( - )
194	0.69	1.61	(63.3)	2.00	(78.7)	-	( - )
200	0.67	1.65	(64.8)	-	( - )	-	( - )
210	0.64	1.71	(67.2)	-	( - )	-	( - )
220	0.61	1.77	(69.6)	-	( - )	-	( - )
230	0.58	1.83	(72.0)	-	( - )	-	( - )
240	0.56	1.89	(74.4)	-	( - )	-	( - )
250	0.54	1.95	(76.9)	-	( - )	-	( - )

For SI: 1 inch = 25.4 mm, 1 inch = 1000 mils

Footnotes:

<sup>1</sup> Empty cells ("-") indicate unknown performance of coating thickness.

<sup>2</sup> The design loads used for testing the steel beam assemblies are based on the worst-case flexural design load of the structural steel beam in accordance with AISC (Specification for Structural Steel Buildings), unless noted otherwise. Both Allowable Strength Design (ASD) and Load and Resistance Factor Design (LRFD) methods were considered.