



ICC-ES Listing Report ELC-2818

Reissued May 2024

This listing is subject to renewal May 2025.

CSI: DIVISION: 03 00 00—CONCRETE
Section: 03 16 00—Concrete Anchors

DIVISION: 05 00 00—METALS
Section: 05 05 19—Post-Installed Concrete Anchors

Product Certification System:

The ICC-ES product-certification system includes evaluating reports of tests of standard manufactured product, prepared by accredited testing laboratories and provided by the listee, to verify compliance with applicable codes and standards. The system also involves factory inspections, and assessment and surveillance of the listee's quality system.

Product: Power-Stud®+ SD1 Expansion Anchors for Cracked and Uncracked Concrete

Listee: DEWALT

Compliance with the following standards:

- Annex D, Anchorage of CSA A23.3 (-14, -04), Design of Concrete Structures, CSA Group.

Compliance with the following codes:

Power-Stud®+ SD1 expansion anchors for cracked and uncracked concrete, as described in this listing report, are in conformance with CSA A23.3 (-14, -04), Annex D, as referenced in the applicable section of the following code editions:

- *National Building Code of Canada*® 2015 and 2010
Applicable Section: Division B, Part 4, Section 4.3.3.

Description of anchors:

Power-Stud+ SD1 expansion anchors are torque-controlled, mechanical expansion anchors comprised of an anchor body, expansion wedge (clip), washer and hex nut. The anchor body and expansion clip are manufactured from medium carbon steel complying with requirements set forth in the approved quality documentation, and have minimum 0.0002-inch-thick (5 µm) zinc plating in accordance with ASTM B633, SC1, Type III. The washers comply with ASTM F844. The hex nuts comply with ASTM A563, Grade A. The Power-Stud+ SD1 expansion anchor is illustrated in Figure 1.

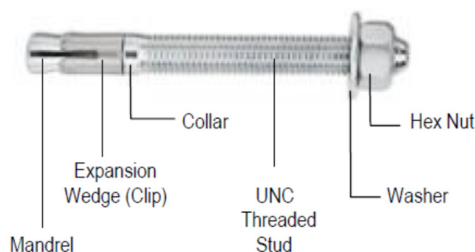

FIGURE 1—POWER-STUD+ SD1 ANCHOR ASSEMBLY

The anchor body is comprised of a high-strength threaded rod at one end and a tapered mandrel at the other end. The tapered mandrel is enclosed by a three-section expansion clip that freely moves around the mandrel. The expansion clip movement is restrained by the mandrel taper and by a collar. The anchors are installed in a predrilled hole with a hammer. When torque is applied to the nut of the installed anchor on the threaded end of the anchor body, the mandrel at the opposite end of the anchor is drawn into the expansion clip, forcing it outward into the sides of the predrilled hole in the base material.

Identification:

1. The Power-Stud+ SD1 expansion anchors are identified by dimensional characteristics and packaging. A length letter code is stamped on each anchor on the exposed threaded stud end which is visible after installation. Table 2 summarizes the length code identification system. A plus sign “+” is also marked with the number “1” on all anchors with the exception of the 1/4-inch-diameter (6.4 mm) anchors. Packages are identified with the product name, type and size, the company name, and the listing report number (ELC-2818); and the ICC-ES listing mark.
2. The report holder’s contact information is the following:

DEWALT
701 EAST JOPPA ROAD
TOWSON, MARYLAND 21286
(800) 524-3244
www.dewalt.com
anchors@dewalt.com

Installation:

The installation parameters are provided in Figure 2 and Table 1. Installation of the Power-Stud+ SD1 expansion anchors must be in accordance with the manufacturer’s published installation instruction (MPII) as provided in the packaging and described in and Figure 2. Anchors must be installed in holes drilled into the concrete using carbide-tipped masonry drill bits complying with ANSI B212.15-1994. Prior to installation, dust and debris must be removed from the drilled hole to enable installation to the stated embedment depth (see Figures 2 and 3). The anchor must be hammered into the predrilled hole until h_{nom} is achieved.

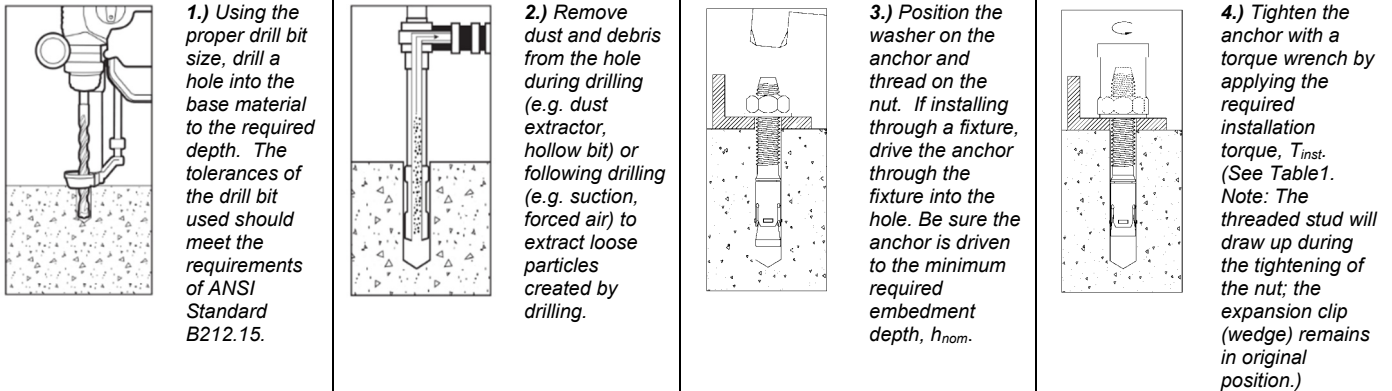









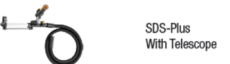



FIGURE 2—POWER-STUD+ SD1 INSTALLATION INSTRUCTIONS

DeWALT Dust Removal Drilling Systems with HEPA Dust Extractor Options		
Tool	Accessories and Shrouds	HEPA Dust Extractor
SDS-Max Drills		
 Cordless  Corded	 SDS-Max Hollow Drill Bit	 Dust Extractor
	 SDS-Max With Shroud	
SDS-Plus Drills		
 Cordless	 SDS-Plus Bit	 Cordless Dust Extractor
	 SDS-Plus Hollow Drill Bit	
 Corded	 SDS-Plus With Telescope	 Dust Extractor
	 SDS-Plus With Shroud	

The DEWALT drilling systems shown collect and remove dust with a HEPA dust extractor during the hole drilling operation in dry base materials using hammer-drills (see manufacturer’s published installation instructions).

FIGURE 3—EXAMPLES OF DEWALT DUST REMOVAL DRILLING SYSTEMS WITH HEPA DUST EXTRACTORS FOR ILLUSTRATION

Anchor setting information:

TABLE 1—POWER-STUD+ SD1 ANCHOR INSTALLATION SPECIFICATIONS IN CONCRETE¹

Anchor Property/Setting Information	Notation	Units	Nominal Anchor Diameter															
			1/4 inch	3/8 inch	1/2 inch		5/8 inch		3/4 inch		7/8 inch	1 inch	1 1/4 inch					
Anchor diameter	d_a	mm (in.)	6.4 (0.250)	9.5 (0.375)	12.7 (0.500)		15.9 (0.675)		19.1 (0.750)		22.2 (0.875)	25.4 (1.000)	31.8 (1.250)					
Minimum diameter of hole clearance in fixture	d_h	mm (in.)	7.5 (⁵ / ₁₆)	11.1 (⁷ / ₁₆)	14.3 (⁹ / ₁₆)		17.5 (¹¹ / ₁₆)		20.6 (¹³ / ₁₆)		25.4 (1)	28.6 (¹¹ / ₈)	34.9 (¹³ / ₈)					
Nominal drill bit diameter	d_{bit}	in.	¹ / ₄ ANSI	³ / ₈ ANSI	¹ / ₂ ANSI		⁵ / ₈ ANSI		³ / ₄ ANSI		⁷ / ₈ ANSI	1 ANSI	¹ / ₄ ANSI					
Nominal embedment depth	h_{nom}	mm	44	60	64	95	86	117	102	143	114	140	165					
Effective embedment depth	h_{ef}	mm	38	51	51	83	70	102	79	114	89	111	137					
Minimum hole depth	h_{hole}	mm	48	64	70	102	95	127	108	149	124	149	184					
Minimum overall anchor length ²	l_{anch}	mm	57	76	95	114	114	152	140	178	203	229	229					
Installation torque	T_{inst}	N-m	5	27	54		108		149		237	305	508					
Torque wrench/socket size	-	in.	⁷ / ₁₆	⁹ / ₁₆	³ / ₄		¹⁵ / ₁₆		1 1/8		¹⁵ / ₁₆	1 1/2	¹⁷ / ₈					
Nut height	-	in.	⁷ / ₃₂	²¹ / ₆₄	⁷ / ₁₆		³⁵ / ₆₄		⁴¹ / ₆₄		³ / ₄	⁵⁵ / ₆₄	¹¹ / ₁₆					
Anchors Installed in Concrete Construction																		
Minimum member thickness	h_{min}	mm	83	95	102	102	152	152	178	152	254	254	254	305				
Minimum edge distance	c_{min}	mm	44	152	70	57	152	95	102	70	152	140	108	127	152	178	203	203
Minimum spacing distance	s_{min}	mm	57	89	229	95	114	254	127	152	152	270	108	152	165	165	203	203
Critical edge distance (uncracked concrete only)	c_{ac}	mm	89	165		203		203		152	254	279	406	292	305	508		

For SI: 1 inch = 25.4 mm, 1 ft-lbf = 1.356 N-m.

¹The information presented in this table is to be used in conjunction with the design criteria of CSA A23.3 (-14, -04) Annex D, as applicable.

²The listed minimum overall anchor length is based on anchor sizes commercially available at the time of publication compared with the requirements to achieve the minimum nominal embedment depth, nut height and washer thickness, and consideration of a possible fixture attachment.

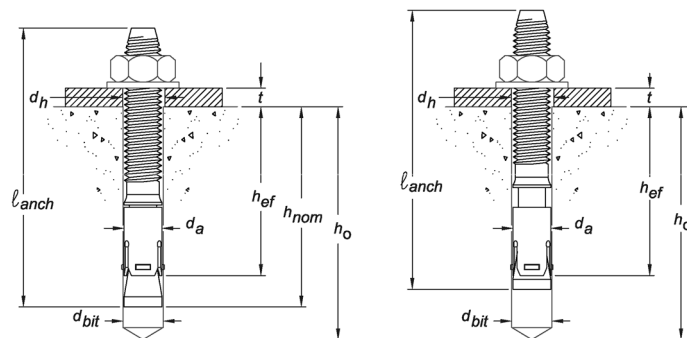

FIGURE 4—POWER-STUD+ SD1 ANCHOR DETAIL
Before (Left Picture) and After (Right Picture) Application of Installation Torque

TABLE 2—POWER-STUD+ SD1 ANCHOR LENGTH CODE IDENTIFICATION SYSTEM

Length ID marking on threaded stud head		A	B	C	D	E	F	G	H	I	J	K	L	M	N	O	P	Q	R	S	T
Overall anchor length, l_{anch} , (mm)	From	38	51	64	76	89	102	114	127	140	152	165	178	191	203	216	229	241	254	279	305
	Up to but not including	51	64	76	89	102	114	127	140	152	165	178	191	203	216	229	241	254	279	305	330

Ultimate Limit States Design:

Design resistance of anchors for compliance with the 2015 NBCC must be determined in accordance with CSA A23.3-14 Annex D, and this listing report.

Design resistance of anchors for compliance with the 2010 NBCC must be determined in accordance with CSA A23.3-04 Annex D, and this listing report.

Design parameters provided in Tables 1, 3, and 4 of this listing report are based on the 2015 NBCC and 2010 NBCC (CSA A23.3-14 and CSA A23.3-04). The limit states design of anchors must comply with CSA A23.3 (-14, -04) D.5.1, except as required in CSA A23.3 (-14, -04) D.4.3.1.

Material resistance factors must be $\phi_c = 0.65$ and $\phi_s = 0.85$ in accordance with CSA A23.3 (-14, 04) Sections 8.4.2 and 8.4.3, and resistance modification factor, R , as given in CSA A23.3-14 Section D.5.3, or CSA A23.3-04 Section D.5.4, and noted in Tables 3 and 4 of this listing report, must be used for load combinations calculated in accordance with Division B, Part 4, Section 4.1.3 of the 2015 and 2010 NBCC, or Annex C of CSA A23.3 (-14, -04). The nominal steel strength N_{sa} or V_{sa} , in Tables 3 and 4 of this listing report must be multiplied by ϕ_s and R to determine the factored resistance N_{sar} or V_{sar} . The nominal pullout strengths $N_{p,uncr}$, $N_{p,cr}$ or $N_{p,eq}$ in Table 3 of this listing report must be multiplied by ϕ_c and R to determine the factored resistance $N_{cpr,uncr}$, $N_{cpr,cr}$, or $N_{cpr,eq}$, respectively..

TABLE 3—TENSION DESIGN INFORMATION FOR POWER-STUD+ SD1 ANCHOR IN CONCRETE^{1,2}

Design Characteristic	Notation	Units	Nominal Anchor Diameter										
			1/4 inch	3/8 inch	1/2 inch	5/8 inch	3/4 inch	7/8 inch	1 inch	1 1/4 inch			
Anchor category	1, 2 or 3	-	1	1	1	1	1	1	1	1	1	1	
STEEL STRENGTH IN TENSION⁴													
Minimum specified yield strength (neck)	f_{ya}	N/mm ²	606	606	551	551	441	400	400	400	400	400	
Minimum specified ultimate tensile strength (neck)	f_{uta}	N/mm ²	758	758	689	689	552	517	517	517	517	517	
Effective tensile stress area (neck)	$A_{se,N}$	mm ²	14.2	34.3	65.7	104.9	150.9	207.5	273.1	484	484	484	
Steel strength in tension ⁴	N_{sa}	kN	10.0	24.3	40.4	64.3	84.5	109.0	143.5	250	250	250	
Resistance modification factor for steel strength, tension ^{3,4}	R	-	0.80										
CONCRETE BREAKOUT STRENGTH IN TENSION⁶													
Effective embedment depth	h_{ef}	mm	38	51	51	83	70	102	79	114	89	111	137
Effectiveness factor for uncracked concrete	k_{uncr}	-	10	10	10	10	10	10	10	10	10	10	11
Effectiveness factor for cracked concrete	k_{cr}	-	Not Applicable	7	7	7	7	9	7	9	10	10	10
Modification factor for cracked and uncracked concrete ⁵	$\psi_{c,N}$	-	1.0	1.0	1.0	1.0	1.0	1.0	1.0	1.0	1.0	1.0	1.0
Critical edge distance (uncracked concrete only)	c_{ac}	mm	See Table 1										
Resistance modification factor for tension, concrete failure modes, Condition B ³	R	-	1.0										
PULLOUT STRENGTH IN TENSION (NON SEISMIC-APPLICATIONS)⁶													
Characteristic pullout strength, uncracked concrete (17.2 MPa) ⁶	$N_{p,uncr}$	kN	See note 7	12.8	14.3	24.6	See note 7	See note 7	See note 7	See note 7	See note 7	See note 7	See note 7
Characteristic pullout strength, cracked concrete (17.2 MPa) ⁶	$N_{p,cr}$	kN	Not Applicable	9.1	See note 7	11.2	See note 7	19.8	See note 7	See note 7	See note 7	See note 7	50.5
Resistance modification factor for tension, pullout strength, Condition B ³	R	-	1.0										
PULLOUT STRENGTH IN TENSION FOR SEISMIC APPLICATIONS⁶													
Characteristic pullout strength, seismic (17.2 MPa) ^{6,9}	$N_{p,eq}$	kN	Not Applicable	9.1	See note 7	11.1	See note 7	19.8	See note 7	See note 7	See note 7	See note 7	50.5
Resistance modification factor for pullout strength, seismic, Condition B ³	R	-	1.0										

For SI: 1 inch = 25.4 mm; 1 ksi = 6.894 N/mm²; 1 lbf = 0.0044 kN.

¹The data in this table is intended to be used with the design provisions of CSA A23.3 (-14, -04) Annex D, as applicable; for anchors resisting seismic load combinations the additional requirements CSA A23.3 (-14, -04) D.4.3, as applicable, must apply.

²Installation must comply with published instructions and details.

³All values of R for use with the load combinations of Division B, Part 4, Section 4.1.3 of the 2015 NBCC or 2010 NBCC, CSA A23.3-14 Annex C or CSA A23.3-04 Annex C, as applicable. Condition B applies where supplementary reinforcement in conformance with CSA A23.3-14 D.5.3(c) or CSA A23.3-04 D.5.4(c), as applicable, is not provided, or where pullout or pryout strength governs. For cases where the presence of supplementary reinforcement can be verified, the strength reduction factors associated with Condition A may be used.

⁴The Power-Stud+ SD1 is considered a ductile steel element as defined CSA A23.3-14 D.2 or CSA A23.3-04 D.2, as applicable. Tabulated values for steel strength in tension are based on test results per ACI 355.2 and must be used for design.

⁵For all design cases use $\psi_{c,N} = 1.0$. The appropriate effectiveness factor for cracked concrete (k_{cr}) or uncracked concrete (k_{uncr}) must be used.

⁶For all design cases use $\psi_{c,P} = 1.0$. For the calculation of N_{spr} , see CSA A23.3 (-14, -04) D.6.3.

⁷Pullout strength does not control design of indicated anchors. Do not calculate pullout strength for indicated anchor size and embedment.

⁸Anchors are permitted to be used in lightweight concrete in accordance with CSA A23.3 (-14, -04) D.4.6.

⁹Tabulated values for characteristic pullout strength in tension are for seismic applications and based on test results in accordance with ACI 355.2 (Section 9.5), as referenced in CSA A23.3-14 Annex D, Section D.4.3.4.

TABLE 4—SHEAR DESIGN INFORMATION FOR POWER-STUD+ SD1 ANCHOR IN CONCRETE^{1,2}

Design Characteristic	Notation	Units	Nominal Anchor Diameter										
			1/4 inch	3/8 inch	1/2 inch	5/8 inch	3/4 inch	7/8 inch	1 inch	1 1/4 inch			
Anchor category	1, 2 or 3	-	1	1	1	1	1	1	1	1	1	1	
STEEL STRENGTH IN SHEAR⁴													
Minimum specified yield strength (threads)	f_{ya}	N/mm ²	482	552	485	485	441	400	400	400	400	400	
Minimum specified ultimate strength (threads)	f_{uta}	N/mm ²	606	689	607	607	552	517	517	517	517	517	
Effective tensile stress area (threads)	$A_{se,v}$	mm ²	20.5	50.0	91.5	145.8	212.4	293.4	384.8	615			
Steel strength in shear ⁵	V_{sa}	kN	4.1	13.3	20.6	40.2	47.3	54.8	39.2	48.6	79.0		
Resistance modification factor for steel strength, shear ^{3,4}	R	-	0.75										
CONCRETE BREAKOUT STRENGTH IN SHEAR⁶													
Load bearing length of anchor (h_{ef} or $8d_a$, whichever is less)	l_e	mm	38	51	51	83	70	102	79	114	88.9	111	137
Nominal anchor diameter	d_a	mm	6.4	9.5	12.7	15.9	19.1	22.2	25.4	31.8			
Resistance modification factor for shear, concrete failure modes, Condition B ³	R	-	1.0										
PRYOUT STRENGTH IN SHEAR⁶													
Coefficient for prout strength (1.0 for $h_{ef} < 2.5$ in., 2.0 for $h_{ef} \geq 2.5$ in.)	k_{cp}	-	1.0	1.0	1.0	2.0	2.0	2.0	2.0	2.0	2.0	2.0	2.0
Effective embedment	h_{ef}	mm	38	51	51	83	70	102	79	114	89	111	137
Resistance modification factor for prout strength ³	R	-	1.0										
STEEL STRENGTH IN SHEAR FOR SEISMIC APPLICATIONS													
Steel strength in shear, seismic ^{5,7}	$V_{sa,eq}$	kN	Not Applicable	10.9	17.6	26.7	38.2	42.9	39.2	43.8	79.0		
Resistance modification factor for steel strength, shear, seismic ³	R	-	0.75										

For SI: 1 inch = 25.4 mm; 1 ksi = 6.894 N/mm²; 1 lbf = 0.0044 kN.

¹The data in this table is intended to be used with the design provisions of CSA A23.3 (-14, -04) Annex D, as applicable; for anchors resisting seismic load combinations the additional requirements CSA A23.3 (-14, -04) D.4.3, as applicable, must apply.

²Installation must comply with published instructions and details.

³All values of R for use with the load combinations of Division B, Part 4, Section 4.1.3 of the 2015 NBCC or 2010 NBCC, CSA A23.3-14 Annex C or CSA A23.3-04 Annex C, as applicable. Condition B applies where supplementary reinforcement in conformance with CSA A23.3-14 D.5.3(c) or CSA A23.3-04 D.5.4(c), as applicable, is not provided, or where pullout or prout strength governs. For cases where the presence of supplementary reinforcement can be verified, the strength reduction factors associated with Condition A may be used.

⁴The Power-Stud+ SD1 is considered a ductile steel element as defined by CSA A23.3-14 D.2 or CSA A23.3-04 D.2, as applicable.

⁵Tabulated values for steel strength in shear must be used for design. These tabulated values are lower than calculated results using equation D.31 in CSA A23.3-14.

⁶Anchors are permitted to be used in lightweight concrete in accordance with CSA A23.3 (-14, -04) D.4.6.

⁷Tabulated values for steel strength in shear are for seismic applications and based on test results in accordance with ACI 355.2 (Section 9.6), as referenced in CSA A23.3-14 Annex D, Section D.4.3.4.

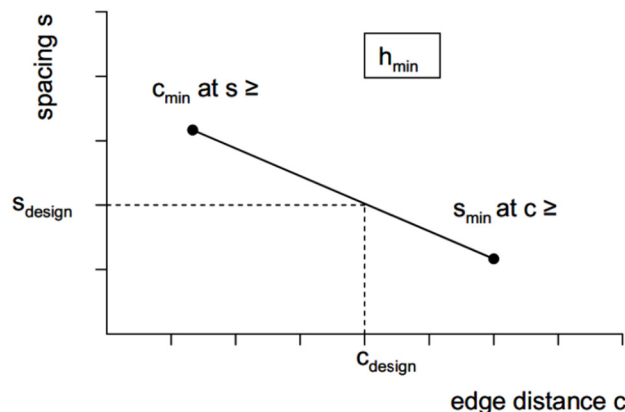

FIGURE 5—INTERPOLATION OF MINIMUM EDGE DISTANCE AND ANCHOR SPACING¹

¹This interpolation applies to the cases when two sets of minimum edge distances, c_{min} , and minimum spacing distances, s_{min} , are given in Table 1 for a given anchor diameter under the same effective embedment depth, h_{ef} , and corresponding minimum member thickness, h_{min} .

Conditions of listing:

1. The listing report addresses only conformance with the standards and code sections noted above.
2. Approval of the product's use is the sole responsibility of the local code official.
3. The listing report applies only to the materials tested and as submitted for review by ICC-ES.
4. Anchor sizes, dimensions, minimum embedment depths and other installation parameters are as set forth in this listing report.
5. The 6.4 mm ($1/4$ -inch) anchors must be installed in uncracked normal-weight or lightweight concrete; 9.5 mm to 31.8 mm ($3/8$ -inch to $1 1/4$ -inch) anchors must be installed in cracked or uncracked normal-weight or lightweight concrete having a specified compressive strength, f'_c , of 17.2 MPa to 58.6 MPa.
6. The values of f'_c , used for calculation purposes must not exceed 55 MPa.
7. Limit states design values must be established in accordance with this listing report.
8. The use of fatigue or shock loading for these anchors under such conditions is beyond the scope of this listing report.
9. Anchors [except the 6.4 mm ($1/4$ -inch)] may be used to resist short-term loading due to wind or seismic forces in locations designed according to NBCC 2015 and NBCC 2010.
10. Where not otherwise prohibited in the code as referenced in CSA A23.3 (-14, -04), Power-Stud+ SD1 expansion anchors are permitted for use with fire-resistance-rated construction provided that at least one of the following conditions is fulfilled:
 - a. Anchors are used to resist wind or seismic forces only.
 - b. Anchors that support a fire-resistance-rated envelope or a fire-resistance-rated membrane are protected by approved fire-resistance-rated materials, or have been evaluated for resistance to fire exposure in accordance with recognized standards.
 - c. Anchors are used to support nonstructural elements.
11. Use of zinc-coated carbon steel anchors is limited to dry, interior locations.
12. Use of anchors made of stainless steel as specified in this report are permitted for exterior exposure and damp environments.
13. Steel anchoring materials in contact with preservative-treated wood and fire-retardant-treated wood must be of zinc-coated carbon steel or stainless steel. The minimum coating weights for zinc-coated steel must comply with ASTM A153.