

ICC-ES Evaluation Report

ESR-2616

Reissued February 2024

This report also contains:



- LABC Supplement

Subject to renewal February 2025

- FBC Supplement

ICC-ES Evaluation Reports are not to be construed as representing aesthetics or any other attributes not specifically addressed, nor are they to be construed as an endorsement of the subject of the report or a recommendation for its use. There is no warranty by ICC Evaluation Service, LLC, express or implied, as to any finding or other matter in this report, or as to any product covered by the report.

Copyright © 2024 ICC Evaluation Service, LLC. All rights reserved.

<p>DIVISION: 06 00 00— WOOD, PLASTICS, AND COMPOSITES</p> <p>Section: 06 05 23— Wood, Plastic, and Composite Fastenings</p>	<p>REPORT HOLDER: SIMPSON STRONG-TIE COMPANY INC.</p> 	<p>EVALUATION SUBJECT: SIMPSON STRONG-TIE® CONNECTORS ATTACHING WOOD MEMBERS TO CONCRETE CONSTRUCTION</p>	
---	---	---	---

1.0 EVALUATION SCOPE

Compliance with the following codes:

- 2021, 2018, 2015, 2012 and 2009 [International Building Code® \(IBC\)](#)
- 2021, 2018, 2015, 2012 and 2009 [International Residential Code \(IRC\)](#)

For evaluation for compliance with codes adopted by the [Los Angeles Department of Building and Safety \(LADBS\)](#), see [ESR-2616 LABC and LARC Supplement](#).

Property evaluated:

Structural

2.0 USES

Simpson Strong-Tie connectors for wood members supported by concrete construction are used as wood framing connectors in accordance with Section 2304.10.4 of the 2021 IBC, Section [2304.10.3](#) of the 2018 IBC or 2015 IBC or [2304.9.3](#) of the 2012 and 2009 IBC. The products may also be used in structures regulated under the IRC when an engineered design is submitted in accordance with Section [R301.1.3](#) of the IRC.

3.0 DESCRIPTION

3.1 General:

The allowable loads for connectors described in this report are based on the reference design values of fasteners in wood, the allowable perpendicular-to-grain values of wood members, the steel strength of the connectors, and testing, as applicable. The anchorage of the connectors to concrete construction, inclusive of cast-in-place and post-installed anchor bolts, is outside of the scope of this report.

3.1.1 UFP10 Universal Foundation Plate: The UFP10 foundation plate connects wood sill plates to concrete foundation stem walls. It is fabricated from No. 14 gage [minimum base steel thickness of 0.0685 inch (1.740 mm)] galvanized steel. The UFP10 has an S-shape profile that is designed for connecting different size wood sill plates and concrete foundation stem walls. Anchor bolts are used to attach the foundation plate to the concrete foundation and Simpson Strong-Tie® Strong-Drive® SDS screws connect the UFP10 to the wood sill plate. See [Table 1](#) for required fasteners and allowable lateral loads. See [Figure 1](#) for drawings of the UFP10 connector and a typical installation detail.

3.1.2 FJA and FSA Foundation Joist/Stud Anchor: The FJA and FSA foundation anchors connect floor joists or studs to concrete foundation stem walls. They are fabricated from No 12 gage [minimum base steel thickness of 0.0975 inch (2.477 mm)] galvanized steel. Anchor bolts connect the anchor to the concrete foundation, and nails or bolts connect the anchor to the floor joist or stud. See [Table 2](#) for the anchor dimensions, required fasteners, and allowable loads. See [Figure 2](#) for drawings of the FJA/FSA connector, and typical installation details.

3.1.3 GH Girder Hangers: The GH girder hangers connect wood floor girders to concrete foundation stem walls. They are fabricated from No. 12 gage [minimum base steel thickness of 0.0975 inch (2.477 mm)] steel, and have a U-shaped stirrup, which supports the wood girder, factory-welded to an inverted U-shaped channel, which bears on top of the concrete foundation stem wall. A wood sill plate must be installed on top of the inverted U-shaped channel. See [Table 3](#) for hanger model numbers, nominal size of wood girders that may be used with specific hangers, hanger dimensions, required fasteners, and allowable downloads. See [Figure 3](#) for drawings of the GH girder hanger and a typical installation detail.

3.1.4 HGT Heavy Girder Tiedowns: The HGT heavy girder tiedowns connect 2-, 3- and 4-ply metal plate connected wood trusses to the top of structural concrete members. The HGT tiedowns are fabricated from No. 7 gage [minimum base steel thickness of 0.1715 inch (4.356 mm)] steel and factory-welded insert plates. The HGT tiedowns have slotted holes at each end for $\frac{3}{4}$ -inch-diameter anchor bolts that are used to connect the tiedown to the structural concrete member. The threaded end of the anchor bolts are fastened with a standard cut washer and nut. Between anchor bolt nut and washer is a crescent-shaped washer that is supplied with the tiedowns. The curved top of the crescent-shaped washers permit the tiedown to be rotated and field adjusted to accommodate top chord slopes from 3:12 (14 degrees) minimum to 8:12 (34 degrees) maximum. See [Table 4](#) for the tiedown model numbers, anchor dimensions, required fasteners and allowable loads. See [Figure 4](#) for a drawing of the HGT heavy girder tiedown and a typical installation detail.

3.1.5 GLB/HGLB/GLBT Glulam Bearing Plates: The GLB, HGLB, and GLBT glulam bearing plates connect structural glued laminated timber beams to structural concrete or masonry members. The GLB, HGLB, and GLBT bearing plate connectors have two No. 3 gage [minimum base steel thickness of 0.2285 inch (5.804 mm)] vertical steel plates, which are factory-welded to the top of the steel bearing plate, with one bolt hole for the GLB bearing plate connectors and two bolt holes for the HGLB and GLBT bearing plate connectors. The GLB and GLBT have two 12-inch-long (305 mm) #6 size deformed rebars factory-welded to the underside of the bearing plate, and the HGLB has three 12-inch-long (305 mm) #6 size deformed rebars factory-welded to the underside of the steel bearing plate. Steel rebar for GLB/HGLB/GLBTs must comply with [ACI 318-14](#). The bearing plates of the GLB and HGLB connectors are flat, rectangular steel plates having the dimensions shown in [Tables 5](#) and [6](#) respectively, and the bearing plate GLBT connector is a structural steel tee with its $3^{13}/16$ -inch-long (97 mm) web embedded into the concrete or masonry member. See [Table 5](#) for GLB model numbers, bearing plate dimensions, required fasteners, and allowable downloads; and see [Table 6](#) for HGLB and GLBT model numbers, bearing plate dimensions, required fasteners, and allowable downloads and lateral loads. See [Figure 5](#) for drawings related to the GLB bearing plate connector, and [Figure 6](#) for drawings related to the HGLB and GLBT bearing plate connectors.

3.1.6 URFP Universal Retrofit Foundation Plate: The URFP foundation plate is a retrofitted foundation plate which connects wood sill plates to concrete foundation stem walls. It is fabricated from No. 14 gage [minimum base steel thickness of 0.0685 inch (1.740 mm)] galvanized steel. URFP is an enhanced design version of UFP10 and has higher allowable lateral load capacity. Anchor bolts are used to attach the URFP to the concrete foundation and SDS screws connect the URFP to the wood sill plate. See [Table 7](#) for fasteners and allowable lateral loads. See [Figure 7](#) for drawings of the URFP connector and a typical installation detail.

3.1.7 FRFP Flat Retrofit Foundation Plate: The FRFP foundation plate is a flat retrofitted foundation plate which connects wood sill plates to concrete foundation stem walls. It is fabricated from No. 7 gage [minimum base steel thickness of 0.1715 inch (4.356 mm)] galvanized steel. Anchor bolts are used to attach the plate to the concrete foundation and SDS screws connect the FRFP to the wood sill plate. When wood sill plate is offset from the foundation edge, shim shall be added so that the FRFP is flush with the foundation edge and the shim. Shim material shall be pressure treated wood similar to the sill plate material. The maximum allowable offset for the wood sill plate is 1.5 inches. The minimum thickness of shim shall be $\frac{3}{16}$ inches and maximum thickness of shim shall be 1.5 inches. Minimum height of shim shall be 1.5 inches and minimum length of shim shall be 12 inches. The shim thickness shall be added to the SDS fastener length of 2.5 inches to obtain the maximum allowable capacity of the FRFP. See [Table 8](#) for required fasteners and allowable lateral loads. See [Figure 8](#) for drawings of the FRFP connector and a typical installation detail.

3.2 Materials:

3.2.1 Steel: The UFP ([Table 1](#)), FJA and FSA ([Table 2](#)), URFP ([Table 7](#)), and FRFP ([Table 8](#)) connectors are fabricated from [ASTM A653](#), SS designation, Grade 33, galvanized sheet steel with a minimum yield strength, F_y , of 33,000 psi (227 MPa) and a minimum tensile strength, F_u , of 45,000 psi (310 MPa). The GH ([Table 3](#)),

HGT (Table 4) and GLB (Table 5) connectors, and the vertical plates only of the HGLB and GLBT (Table 6) connectors are fabricated from ASTM A1011 designation, Grade 33, hot-rolled steel with a minimum yield strength of 33,000 psi (227 MPa) and a minimum tensile strength of 52,000 psi (359 MPa). The insert plates of the HGT (Table 4) connectors are made from ASTM A36 hot rolled steel with a minimum yield strength of 36,000 psi (248 MPa) and tensile strength of 58,000 psi (400 MPa). The bearing plate of the GLBT (Table 6) connectors is a WT4×9 structural tee made from ASTM A36 hot-rolled steel with minimum yield strength of 36,000 psi (248 MPa) and a minimum tensile strength of 58,000 psi (400 MPa). Rebars factory-welded to GLB (Table 5) connectors and HGLB and GLBT (Table 6) connectors are No. 6 deformed steel reinforcement bars complying with ASTM A706 with minimum yield strength of 40,000 psi (276 MPa) and a minimum tensile strength of 70,000 psi (482 MPa).

The UFP (Table 1), FJA and FSA (Table 2), URFP (Table 7) and FRFP (Table 8) connectors have a minimum G90 zinc coating designation in accordance with ASTM A653. Some models (designated with a model number ending with Z) are available with a G185 zinc coating designation in accordance with ASTM A653. Some models (designated with a model number ending with HDG) are available with a hot-dip galvanization, also known as “batch” galvanization, in accordance with ASTM A123, with a minimum specified coating weight of 2.0 ounces of zinc per square foot of surface area (610 g/m²), total for both sides. Model numbers in this report do not include the Z or HDG ending, but the information shown applies. The GH (Table 3), HGT (Table 4), GLB (Table 5), and HGLB and GLBT (Table 6) connectors have a painted finish. The lumber treater and the holder of this report (Simpson Strong-Tie Company) should be contacted for recommendations on the appropriate coating or material to specify for use of the steel connectors in contact with the specific proprietary preservative-treated or fire-retardant-treated lumber. Connectors in contact with the preservative-treated or fire-retardant-treated wood must comply with 2304.10.5 of the 2018 and 2015 IBC, 2012 and 2009 IBC Section 2304.9.5, 2018, 2015, 2012, and 2009 IRC Section R317.3 or 2006 IRC Section R319.3, as applicable.

The steel connectors described in this report have the following minimum base-metal thicknesses:

NOMINAL THICKNESS (gage)	MINIMUM BASE-METAL THICKNESS (inch)
No. 3	0.2285
No. 7	0.1715
No. 12	0.0975
No. 14	0.0685

For SI: 1 inch = 25.4 mm.

3.2.2 Wood: Wood members with which the connectors are used must be either sawn lumber or engineered lumber having a minimum specific gravity of 0.50 (minimum equivalent specific gravity of 0.50 for engineered lumber), and having a maximum moisture content of 19 percent (16 percent for engineered lumber) except as noted in Section 4.1. The thickness of the supporting wood member must be equal to or greater than the length of the fasteners specified in the tables in this report, or as required by wood member design, whichever is greater. For installation in engineered wood members, minimum allowable nail spacing and end and edge distances, as specified in the applicable evaluation report for the engineered wood product, must be met.

3.2.3 Fasteners: Nails used for hangers described in this report must be bright or hot-dipped galvanized carbon steel nails complying with ASTM F1667 as reference in Section 2303.6 of the IBC. Alternatively, nails of other materials or finishes may be used when they are recognized in an ICC-ES evaluation report as having bending yield strength (F_{yb}) and withdrawal capacity equal to or better than those of a bright carbon steel nail of the same nominal diameter as required by this evaluation report and as shown in the following table:

NAIL	SHANK DIAMETER (inch)	FASTENER LENGTH (inches)	F_{yb} (psi)
10d×1½	0.148	1½	90,000
10d	0.148	3	90,000
16d	0.162	3½	90,000

For SI: 1 inch = 25.4 mm, 1 psi = 6.895 kPa.

At a minimum, bolts must comply with ASTM A36 or A307.

Strong-Drive SDS screws are manufactured by Simpson Strong-Tie (ESR-2236).

Nails used in contact with preservative-treated or fire-retardant-treated lumber must be hot-dipped galvanized carbon steel nails. Nails of other materials or finishes may be used when they are recognized in an ICC-ES evaluation for use in the applicable treated lumber. Bolts used in contact with preservative-treated or fire-retardant-treated lumber must comply with Section 2304.10.6 of the 2021 IBC, Section 2304.10.5 of the 2018 or 2015 IBC, Section 2304.9.5 of the 2012 IBC, IRC Section R317.3, as applicable. SDS screws used in contact with preservative-treated or fire-retardant-treated lumber must, comply with [ESR-2236](#) at a minimum. For use with treated lumber, the lumber treater or the holder of this report (Simpson Strong-Tie Company), or both, should be contacted for recommendations on the appropriate coating or material to specify for the fasteners as well as the connection capacities of fasteners used with the specific proprietary preservative-treated or fire-retardant-treated lumber.

3.2.4 Concrete and Masonry Construction: Materials and quality of concrete and masonry construction must comply with the applicable provisions of [Chapter 19](#) or [Chapter 21](#) of the IBC. The compressive strength of the concrete or masonry construction must be in accordance with the approved design and applicable provisions of the building code.

4.0 DESIGN AND INSTALLATION

4.1 Design:

The tabulated allowable loads shown in the product tables of this report are based on allowable stress design and include the load duration factor, C_D , corresponding with the applicable loads in accordance with the *National Design Specification® for Wood Construction* (NDS) and its Supplement.

Tabulated allowable loads apply to products connected to wood used under dry conditions and where sustained temperatures are 100°F (37.8°C) or less. When products are connected to wood having a moisture content greater than 19 percent (16 percent for engineered wood products), or where wet service is expected, the allowable tension loads must be adjusted by the wet service factor, C_M , specified in the NDS for dowel-type fasteners. When connectors are installed in wood that will experience sustained exposure to temperatures exceeding 100°F (37.8°C), the allowable loads in this report must be adjusted by the applicable temperature factor, C_t , specified in the NDS. Connected wood members must be analyzed for load-carrying capacity at the connection in accordance with the NDS.

4.2 Installation:

Installation of the connectors must be in accordance with this evaluation report and the manufacturer's published installation instructions. Bolts installed in wood or engineered wood members must be installed in accordance with the applicable provisions of the NDS. In the event of a conflict between this report and the manufacturer's published installation instructions, this report governs.

4.3 Special Inspection:

4.3.1 Periodic special inspection must be conducted when the connectors are components within the main wind-force-resisting system of structures constructed in areas listed in 2021 IBC Section 1705.12, 2018 or 2015 IBC Section [1705.11](#), 2012 IBC Section [1705.10](#), or 2009 IBC Section [1706.1](#). Special inspection requirements do not apply to structures, or portions thereof, that qualify for exception under Sections 1704.2, 1705.3 and 1705.12,1 of the 2021 IBC, Sections 1704.2, 1705.3 and 1705.11.1 of the 2018 and 2015 IBC, Sections [1704.2](#), [1705.3](#), [1705.10.1](#) of the 2012 IBC, or Sections [1704.1](#), [1704.4](#), and [1706.2](#) of the 2009 IBC.

4.3.2 Periodic special inspections must be conducted in accordance with the applicable subsections of IBC Section [1707](#) when the connectors are components within the seismic-force-resisting system of structures constructed in Seismic Design Category C, D, E or F. Special inspection requirements do not apply to structures, or portions thereof, that qualify for exception under Sections 1704.2, 1705.3 of the 2021, 2018, 2015, and 2012 IBC, Sections 1705.13, 1705.13.1, 1705.13.2 of the 2021 IBC, Sections [1705.12](#), [1705.12.1](#), [1705.12.2](#) of the 2018 or 2015 IBC, Sections [1705.11](#), [1705.11.1](#), and [1705.11.2](#) of the 2012 IBC or Section [1705.3.1](#) of the 2009 IBC and Sections 1704.1, 1704.4, [1705.3](#), and [1707.3](#) of the 2009 IBC.

4.3.3 For installations under the IRC, special inspection is not normally required. However, for an engineered design where calculations are required to be signed by a registered design professional, periodic special inspection requirements and exemptions are as stated in Sections 4.3.1 and 4.3.2, as applicable, for installations under the IRC.

5.0 CONDITIONS OF USE:

The Simpson Strong-Tie products described in this report comply with, or are suitable alternatives to what is specified in, those codes listed in Section [1.0](#) of this report, subject to the following conditions:

- 5.1** The connectors must be manufactured, identified and installed in accordance with this report and the manufacturer's published installation instructions. A copy of the instructions must be available at the jobsite at all times during installation.

- 5.2 Calculations showing compliance with this report must be submitted to the code official. The calculations must be prepared by a registered design professional where required by the statutes of the jurisdiction in which the project is to be constructed.
- 5.3 Adjustment factors noted in Section 4.1 and the applicable codes must be considered, where applicable.
- 5.4 Connected wood members and fasteners must comply with Sections 3.2.2 and 3.2.3, respectively, of this report.
- 5.5 Use of connectors with preservative-treated or fire-retardant-treated lumber must be in accordance with Section 3.2.1 of this report. Use of fasteners with preservative-treated or fire-retardant-treated lumber must be in accordance with Section 3.2.3 of this report.
- 5.6 The design of the anchorage to concrete construction specified in this report, inclusive of cast-in-place and post-installed anchors, used to attach the connectors described in this report to concrete construction, is outside of the scope of this report.
- 5.7 Welded connectors are manufactured under a quality control program with inspections by ICC-ES.

6.0 EVIDENCE SUBMITTED

Data in accordance with the [ICC-ES Acceptance Criteria for Joist Hangers and Similar Devices \(AC13\)](#), dated October 2018.

7.0 IDENTIFICATION

- 7.1 The products described in this report are identified with a die-stamped label or an adhesive label indicating the name of the manufacturer (Simpson Strong-Tie), the model number, and the number of an index evaluation report ([ESR-2523](#)) that is used as an identifier for the products recognized in this report. Additionally, the factory-welded connectors are manufactured in the United States and Canada.
- 7.2 The report holder’s contact information is the following:

SIMPSON STRONG-TIE COMPANY INC.
5956 WEST LAS POSITAS BOULEVARD
PLEASANTON, CALIFORNIA 94588
(800) 999-5099
www.strongtie.com

TABLE 1—UFP UNIVERSAL FOUNDATION PLATE

MODEL NO.	FASTENERS		ALLOWABLE LATERAL (F ₁) LOADS ^{1,2,3,4} (lbs)
	Anchor Bolt ⁵ (Quantity – Dia.)	Screws Fastened to Plate (Quantity-Type)	C _D = 1.6
UFP10-SDS3	2 – 1/2"	5 - SDS ¹ / ₄ x 3	1,415

For SI: 1 inch = 25.4 mm, 1 lb = 4.45 N.

¹Allowable loads have been increased for wind or earthquake loading with no further increase allowed. Allowable loads must be reduced when other load durations govern.

²The footing must be normal-weight concrete having a minimum compressive strength consistent with Sections 1808.8 and 1904.2 of the 2021, 2018, 2015, and 2012 IBC, or Sections 1808.8 and 1904.3 of the 2009 IBC, or Section R402.2 of the IRC, as applicable.

³Not for use to resist uplift.

⁴The parallel to sill plate direction demand load must be less than the minimum of the Allowable Lateral Load (F₁) of the UFP connector and the allowable anchorage capacity of the anchor bolts as determined in footnote 5.

⁵Design of the 1/2-inch diameter anchor bolts into the concrete footing must be determined in accordance with Section 1908 of the 2021 IBC, Sections 1908 or 1909 of the 2018, 2015, or 2012 IBC, or Section 1911 or Section 1912 of the 2009, as applicable. Alternatively, the anchorage to concrete may be in accordance with a current ICC-ES evaluation report.

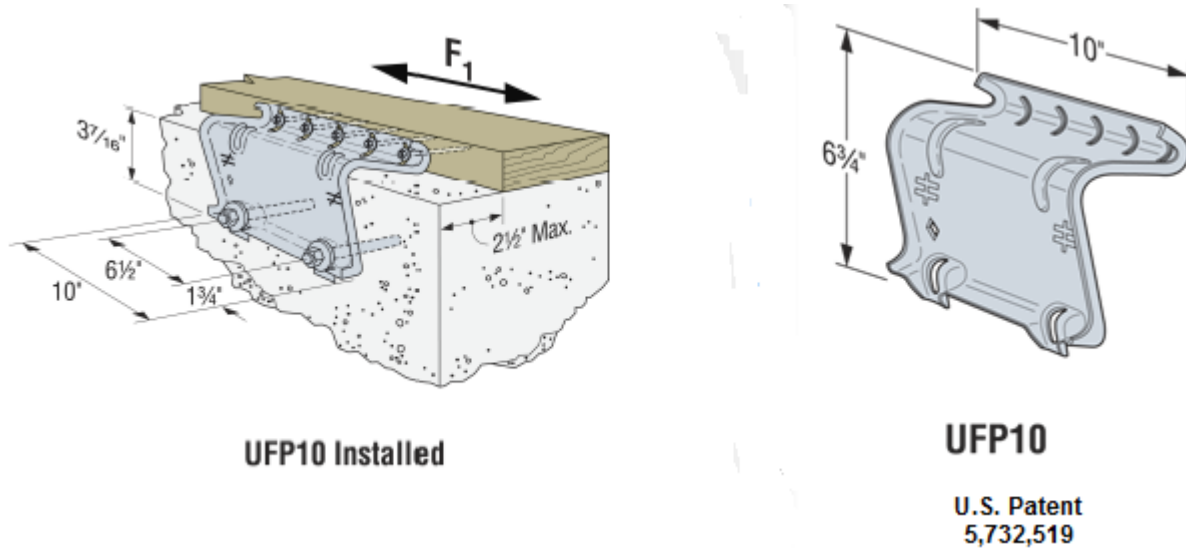

FIGURE 1—UFP UNIVERSAL FOUNDATION PLATE

TABLE 2—FJA AND FSA JOIST/STUD FOUNDATION ANCHORS

MODEL NO.	DIMENSIONS (inches)		FASTENERS		ALLOWABLE LOADS ^{1,2,3} (lbs) C _D = 1.6			
	Length	Width	Anchor Bolts ⁴ (Quantity – Dia.)	Nails or Bolts Fastened to Stud or Joist ⁵ (Quantity-Type)	Uplift ⁶		Lateral	
					Nails	Bolts	F ₁	F ₂
FJA	19 1/2	2 1/2	2 – 1/2"	8–10d x 1 1/2 Nails	1,250	710	205	55
			2 – 1/2"	2–1/2" Dia. Bolts	1,250	710	205	55
FSA	25 1/2	2 1/2	2 – 1/2"	8–10d x 1 1/2 Nails	1,250	710	—	—
			2 – 1/2"	2–1/2" Dia. Bolts	1,250	710	—	—

For SI: 1 inch = 25.4 mm, 1 lb = 4.45 N 1 psi = 6.895 kPa.

¹Allowable loads have been increased for wind or earthquake loading with no further increase allowed. Allowable loads must be reduced when other load durations govern.

²The footing must be normal-weight concrete having a minimum compressive strength consistent with Sections 1808.8 and 1904.2 of the 2021, 2018, 2015, or 2012 IBC, or Sections 1808.8 and 1904.3 of the 2009 IBC, or Section R402.2 of the IRC, as applicable.

³The allowable shear (F₁) and pullout (F₂) loads or nominal strengths of the anchor bolts must be greater than the tabulated allowable shear (F₁) and pullout (F₂) loads of the FJA and FSA connectors.

⁴Design of the 1/2-inch diameter anchor bolts into the concrete footing must be determined in accordance with Sections 1908 or 1909 of the 2021, 2018, 2015, or 2012 IBC, or Section 1911 or Section 1912 of the 2009, as applicable. Alternatively, the anchorage to concrete may be in accordance with a current ICC-ES evaluation report.

⁵Nails and bolts used with the FJA and FSA connectors and engineered wood lumber products must also comply with the minimum edge and spacing limitations specified in the evaluation report for the specific engineered wood lumber products.

⁶Allowable uplift loads are for bolts installed into wood joist members and loaded perpendicular-to-grain.

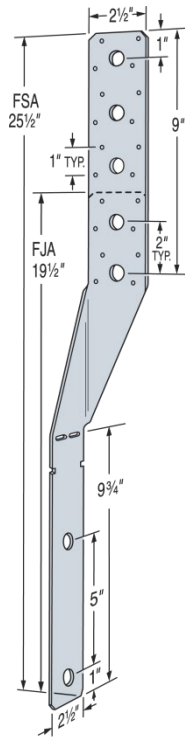

FJA / FSA

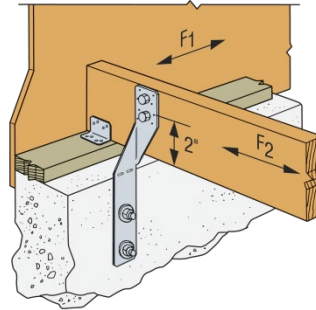

Typical FJA Foundation-to-joist Installation

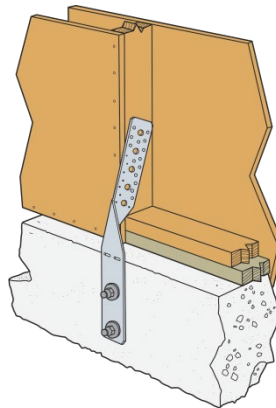

Typical FSA Foundation-to-Stud Installation

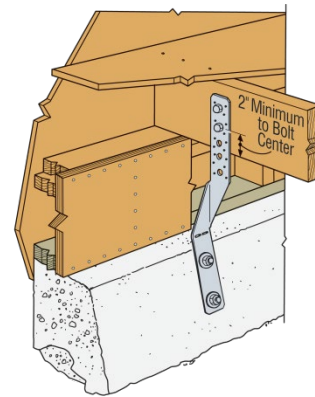

Typical FSA Foundation-to-joist Installation

FIGURE 2—FJA AND FSA JOIST/STUD FOUNDATION ANCHORS

TABLE 3—GH SERIES GIRDER HANGER^{1,2}

MODEL NO.	NOMINAL GIRDER SIZE	DIMENSIONS (inches)				NAILS FASTENED TO GIRDER (Quantity – Type)	ALLOWABLE DOWNLOAD ³ (lbs) C _D = 1.0 C _D = 1.15 C _D = 1.25
		H ⁴	W	L	S		
GH46-6	4x6	4	3 ⁹ / ₁₆	6	6 ¹ / ₁₆	4 – 16d	4,650
GH46-8	4x6	4	3 ⁹ / ₁₆	6	8 ¹ / ₁₆		4,650
GH48-6	4x8	6	3 ⁹ / ₁₆	6	6 ¹ / ₁₆		4,650
GH48-8	4x8	6	3 ⁹ / ₁₆	6	8 ¹ / ₁₆		4,650
GH410-6	4x10	8	7 ⁵ / ₈	6	6 ¹ / ₁₆		4,650
GH410-8	4x10	8	7 ⁵ / ₈	6	8 ¹ / ₁₆		4,650
GH66-6	6x6	4	5 ¹ / ₂	8	6 ¹ / ₁₆		4,650
GH66-8	6x6	4	5 ¹ / ₂	8	8 ¹ / ₁₆		4,650
GH68-6	6x8	6	5 ¹ / ₂	8	6 ¹ / ₁₆		4,650
GH68-8	6x8	6	5 ¹ / ₂	8	8 ¹ / ₁₆		4,650
GH610-6	6x10	8	5 ¹ / ₂	8	6 ¹ / ₁₆		4,650
GH610-8	6x10	8	5 ¹ / ₂	8	8 ¹ / ₁₆		4,650

For SI: 1 inch = 25.4 mm, 1 lb = 4.45 N.

¹GH girder hangers must be mounted on top of concrete wall construction and under a minimum nominal 2-inch by 6-inch wood plate. The 1 1/2-inch diameter clearance hole accommodates anchor bolts used to attach the wood plate to the concrete construction. Anchorage of the GH hanger to concrete wall construction is not necessary since a nominal 2-inch-thick wood plate (mudsill) placed on top of the GH is required to achieve the tabulated loads.

²Uplift loads do not apply for GH hangers.

³Allowable download is the same value regardless of the duration of load as permitted by the applicable building code.

⁴Dimension H, the hanger height, is equal to the girder height minus the wood plate thickness.

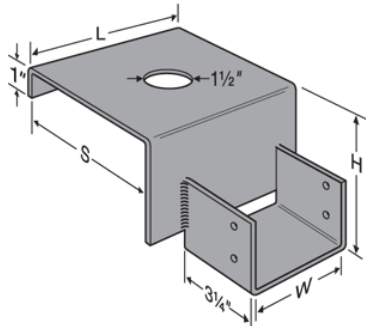

GH Girder Hanger

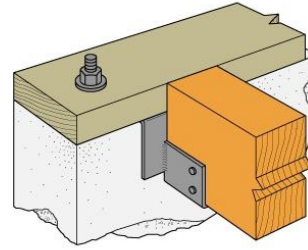

Typical GH Girder Hanger Installation

FIGURE 3—GH GIRDER HANGERS

TABLE 4—HGT SERIES HEAVY GIRDER TIEDOWN¹

MODEL NO.	DIMENSIONS (inches)		FASTENERS		ALLOWABLE UPLIFT LOADS ^{2,3} (lbs) C _D = 1.33 C _D = 1.6
	W	Anchor Spacing	Anchor Bolts ^{4,5} (Quantity – Dia.)	Nails Fastened to Girder (Quantity – Type)	
HGT-2	3 ⁵ / ₁₆	5 ³ / ₄	2 – 3/4"	16 – 10d	10,690
HGT-3 ⁶	4 ¹⁵ / ₁₆	7 ³ / ₈	2 – 3/4"	16 – 10d	10,790
HGT-4	6 ⁹ / ₁₆	9	2 – 3/4"	16 – 10d	11,455

For SI: 1 inch = 25.4 mm, 1 lb = 4.45 N.

¹The HGT is available in sizes for 2-, 3-, and 4-ply metal plate connected wood trusses.

²The allowable uplift loads have been increased for wind or earthquake loading with no further increase is allowed. Allowable uplift loads must be reduced when other load durations govern.

³Attached members must be designed to resist applied loads.

⁴Design of the 3/4"-inch diameter anchor bolts into concrete construction must be determined in accordance with Section 1908 or 1909 of the 2021, 2018, 2015, or 2012 IBC, or Section 1911 or 1912 of the 2009 depending on the code used to regulate construction. Alternatively, the anchorage to concrete may be in accordance with a current evaluation report.

⁵The allowable pullout capacity or nominal strength of the anchorage to concrete needs to be greater than the tabulated allowable uplift load of the HGT tiedowns.

⁶When the HGT-3 is used with a 2-ply truss, shimming must be provided. Shimming must be a similar size and grade of lumber as the girder, and the entire assembly must be fastened to act as one unit.

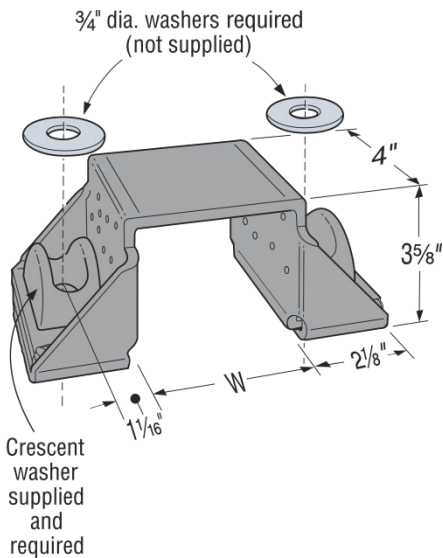

HGT-2 Heavy Girder Tiedown (HGT-3 and HGT-4 similar)

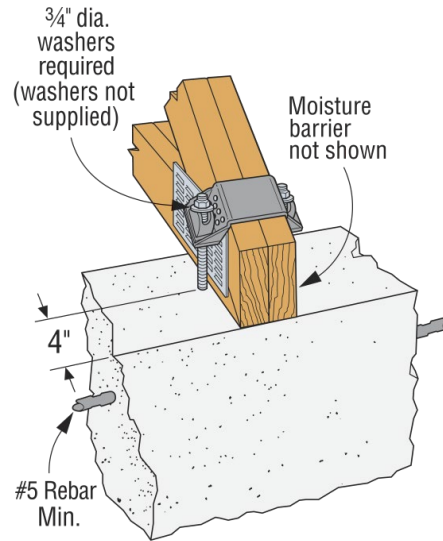

Typical HGT-2 Installation to Concrete Construction

FIGURE 4—HGT HEAVY GIRDER TIEDOWNS

TABLE 5—GLB SERIES GLULAM BEARING PLATE⁵

MODEL NO.	DIMENSIONS (inches)			BOLTS (Quantity – Dia.)	ALLOWABLE DOWNLOADS ^{1,2,3,4} (lbs)		
	Width for Beam (W)	Bearing Plate			Wood ($F_{c\perp} = 650$ psi)	Masonry ($0.25 f'_m = 375$ psi)	
		Depth (PD)	Width (PW)				Thickness (PT)
GLB5A	5 1/4	5	7	0.229	1 – 1/2	16,655	13,125
GLB5B		6	7	0.375	1 – 1/2	19,990	15,750
GLB5C		7	7	0.375	1 – 1/2	23,230	18,375
GLB5D		8	7	0.375	1 – 1/2	26,650	21,000
GLB7A	6 7/8	5	9	0.229	1 – 3/4	21,940	16,875
GLB7B		6	9	0.375	1 – 3/4	26,325	20,250
GLB7C		7	9	0.375	1 – 3/4	30,175	23,625
GLB7D		8	9	0.375	1 – 3/4	35,100	27,000

For SI: 1 inch = 25.4 mm, 1 lbf = 4.45 N, 1 psi = 6.895 kPa.

¹Allowable download based on wood is the same value regardless of the duration of load as permitted by the applicable building code since it is based on the allowable perpendicular-to-grain stress, $F_{c\perp}$, value of 650 psi for the supported wood girder and requires bearing on the full depth (PD) of the GLB connector.

²Design of the structural concrete or structural masonry support member and the anchorage of the GLB connector to the support member must be in accordance with the applicable provisions of the code, including code requirements for a continuous load path and interconnection resisting horizontal lateral loads acting parallel to the beam when seismic design governs.

³The connector plates must bear fully on the supporting structural concrete or masonry member.

⁴The supported glued laminated wood member must bear the full depth (PD) of the bearing plate.

⁵For concrete support members, minimum concrete compressive strength, f'_c , must be 2,500 psi, when GLB Series glulam bearing plate is installed, in which case wood bearing strength governs.

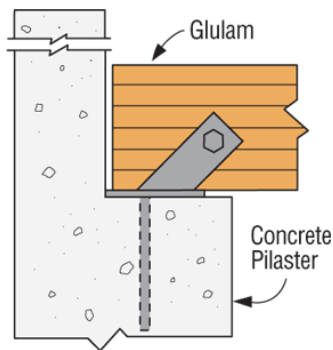

Figure 5a: Typical GLB installation on a concrete pilaster, except the supported glued laminated wood beam must bear on the full depth (PD) of the bearing plate. This drawing is intended to emphasize the code requirement of providing a 1/2-inch air space between the end of the glulam wood member and exterior concrete as required by Section 2304.12.2.4 of the 2021 IBC or Section 2304.12.2.5 of the 2018, 2015, 2012, 2009 and 2006 IBC.

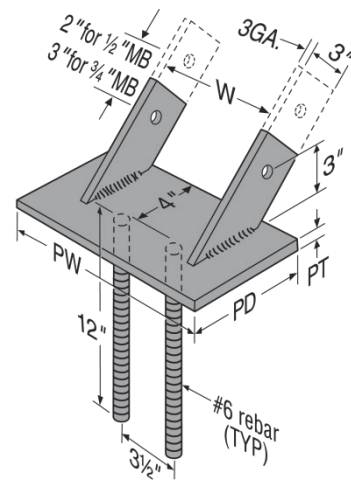

Figure 5b: GLB Bearing Plate Connector

FIGURE 5—GLB GLULAM BEARING PLATE CONNECTOR

TABLE 6—GLBT AND HGLB SERIES GLULAM BEARING PLATES⁷

MODEL NO.	DIMENSIONS (in.)				BOLTS (Qty. - Dia.)	ALLOWABLE LOADS ¹ (lbs)					Lateral Load ^{5,6} Parallel to the Glulam Beam C _D = 1.6
	Width for Beam (W)	Bearing Plate				Download ^{2,3,4} C _D = 1.0 C _D = 1.15 C _D = 1.25					
		Depth (PD)	Width (PW)	Thickness (PT)		Glulam Beam Width (in.)					
						3 ¹ / ₈	5 ¹ / ₈	6 ³ / ₄	8 ³ / ₄	10 ³ / ₄	
HGLBA	3 ¹ / ₄ to 9	5	10	3 ³ / ₈	2 - 3 ³ / ₄	10,155	16,655	21,940	28,440	—	10,305
HGLBB		6	10	3 ³ / ₈	2 - 3 ³ / ₄	12,190	19,990	26,325	34,125	—	10,305
HGLBC		7	10	3 ³ / ₈	2 - 3 ³ / ₄	14,220	23,320	30,715	39,815	—	10,305
HGLBD		8	10	3 ³ / ₈	2 - 3 ³ / ₄	16,250	26,650	35,100	45,500	—	10,305
GLBT512	3 ¹ / ₄ to 11	5 ¹ / ₄	12	5 ⁵ / ₁₆	2 - 3 ³ / ₄	10,665	17,490	23,035	29,860	36,685	10,305
GLBT612		6 ¹ / ₂	12	3 ³ / ₈	2 - 3 ³ / ₄	13,205	21,655	28,520	36,970	45,420	10,305
GLBT516	3 ¹ / ₄ to 15	5 ¹ / ₄	16	5 ⁵ / ₁₆	2 - 3 ³ / ₄	10,665	17,490	23,035	29,860	36,685	10,305
GLBT616		6 ¹ / ₂	16	3 ³ / ₈	2 - 3 ³ / ₄	13,205	21,655	28,520	36,970	45,420	10,305
GLBT520	3 ¹ / ₄ to 19	5 ¹ / ₄	20	5 ⁵ / ₁₆	2 - 3 ³ / ₄	10,665	17,490	23,035	29,860	36,685	10,305
GLBT620		6 ¹ / ₂	20	3 ³ / ₈	2 - 3 ³ / ₄	13,205	21,655	28,520	36,970	45,420	10,305

For SI: 1 inch = 25.4 mm, 1 lb = 4.45 N, 1 psi = 6.895 kPa.

¹Design of the concrete member and the anchorage of the GLB connector to the concrete must be in accordance with the applicable provisions of the code, including code requirements for a continuous load path and interconnection resisting horizontal lateral loads acting along the long axis of the beam when seismic design governs.

²Allowable downloads have the same value regardless of the duration of load as permitted by the applicable building code since their capacity are based on the allowable perpendicular-to-grain stress, F_{c⊥}, value of 650 psi of supported wood girders bearing on the full depth (PD) of the GLB connector.

³The connector plates must bear fully on the supporting structural concrete member.

⁴The supported glued laminated wood member must bear the full depth (PD) of the bearing plate.

⁵Allowable lateral loads acting along the long axis of the beam have been increased for wind or earthquake loading with no further increase is allowed. Allowable lateral loads must be reduced when other load durations govern.

⁶Tabulated allowable lateral loads are based on reference lateral design values for of 3/4-inch diameter bolts used in symmetric double shear connections, with applied loading parallel-to-grain of the connected glued-laminated wood member.

⁷Minimum concrete compressive strength, f'_c, must be 2,500 psi, when GLB Series glulam bearing plate is installed.

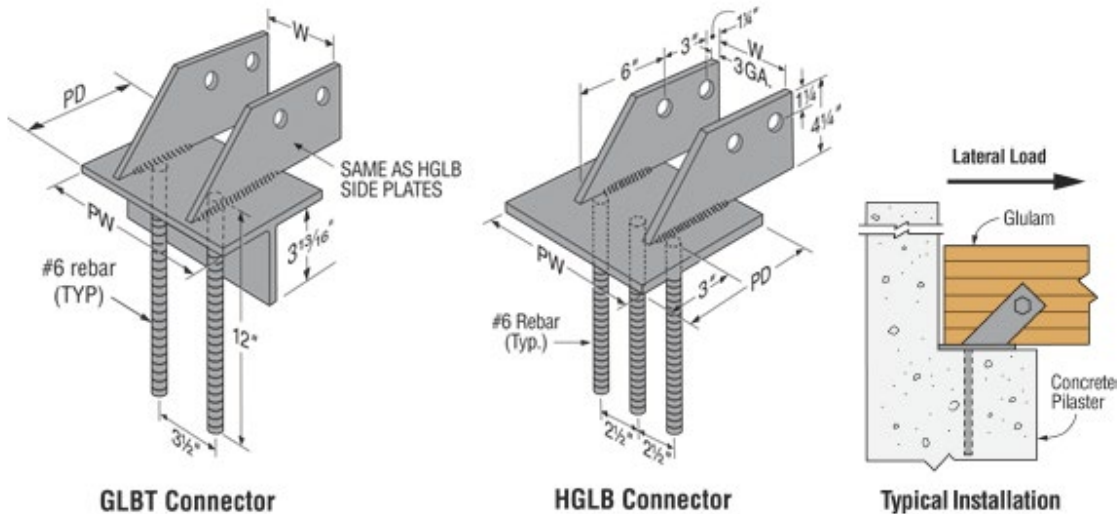

FIGURE 6—HGLB AND GLBT GLULAM BEARING PLATE CONNECTORS

TABLE 7—URFP UNIVERSAL RETROFIT FOUNDATION PLATE^{1,2,3,4,5,6}

Model No.	FASTENERS			ALLOWABLE LATERAL (F1) LOADS (lbs)
	Anchor Bolt		Sill Plate	
	Qty.	Dia.		C _d = 1.6
URFP	2	1/2	5-SDS 1/4"x3"	1530

For **SI**: 1 inch = 25.4 mm, 1 lb = 4.45 N

¹ Allowable loads have been increased for wind or earthquake loading with no further increase allowed; reduce where other load durations apply.

² Each anchor bolt requires a standard cut washer unless the anchor used is provided with a preassembled washer already in place.

³ The footing must be normal-weight concrete having a minimum compressive strength consistent with Sections 1808.8 and 1904.2 of the 2021, 2018, 2015, or 2012 IBC, or Sections 1808.8 and 1904.3 of the 2009 IBC, depending on the code used to regulate construction. Alternatively, the anchorage to concrete may be in accordance with a current evaluation report.

⁴ Not for use to resist uplift or loads perpendicular to wall plate.

⁵ The parallel to sill plate direction demand load must be less than the minimum of the Allowable Lateral Load (F1) of the URFP connector and the allowable anchorage capacity of the anchor bolts as determined in footnote 6.

⁶ Design of the 1/2-inch diameter anchor bolts into the concrete footing must be determined in accordance with Section 1901.3 of the 2021, 2018, or 2015 IBC, Sections 1905 or 1908 of the 2012 IBC, or Sections 1911 or 1912 of the 2009 IBC. Alternatively, the anchorage to concrete may be in accordance with a current ICC-ES evaluation report.

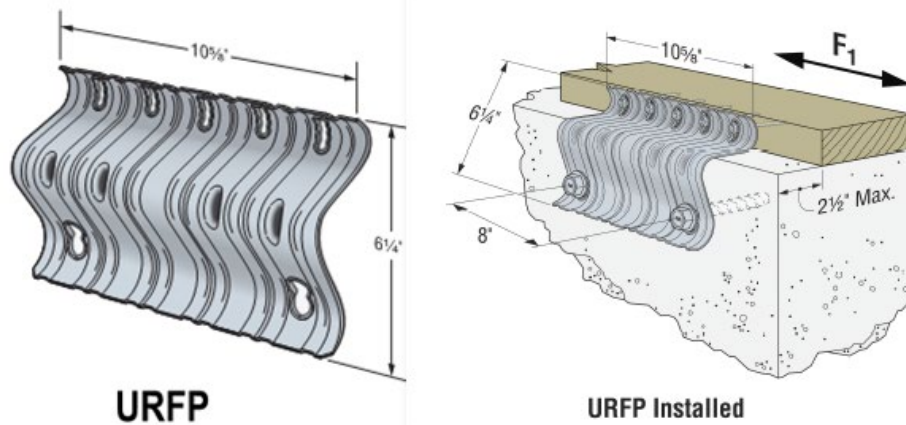

FIGURE 7—URFP UNIVERSAL RETROFIT FOUNDATION PLATE

TABLE 8—FRFP FLAT RETROFIT FOUNDATION PLATE^{1,2,3,4,5,6}

Model No.	FASTENERS			ALLOWABLE LATERAL (F1) LOADS (lbs)
	Anchor Bolt		Sill Plate	
	Qty.	Dia.		C _d = 1.6
FRFP	2	1/2	5-SDS 1/4"x2 1/2" + shim thickness	1810

For SI: 1 inch = 25.4 mm, 1 lb = 4.45 N.

¹Allowable loads have been increased for wind or earthquake loading with no further increase allowed; reduce where other load durations apply.

²Each anchor bolt requires a standard cut washer unless the anchor used is provided with a preassembled washer already in place.

³The footing must be normal-weight concrete having a minimum compressive strength consistent with Sections 1808.8 and 1904.2 of the 2021, 2018, 2015, and 2012 IBC, or Sections 1808.8 and 1904.3 of the 2009 IBC, depending on the code used to regulate construction. Alternatively, the anchorage to concrete may be in accordance with a current evaluation report.

⁴Not for use to resist uplift or loads perpendicular to the wall plate.

⁵The parallel to sill plate direction demand load must be less than the minimum of the Allowable Lateral Load (F1) of the FRFP connector and the allowable anchorage capacity of the anchor bolts as determined in footnote 6.

⁶Design of the 1/2-inch diameter anchor bolts into the concrete footing must be determined in accordance with Sections 1908 or 1909 of the 2021, 2018, 2015, and 2012 IBC, or Sections 1911 or 1912 of the 2009 IBC. Alternatively, the anchorage to concrete may be in accordance with a current ICC-ES evaluation report.

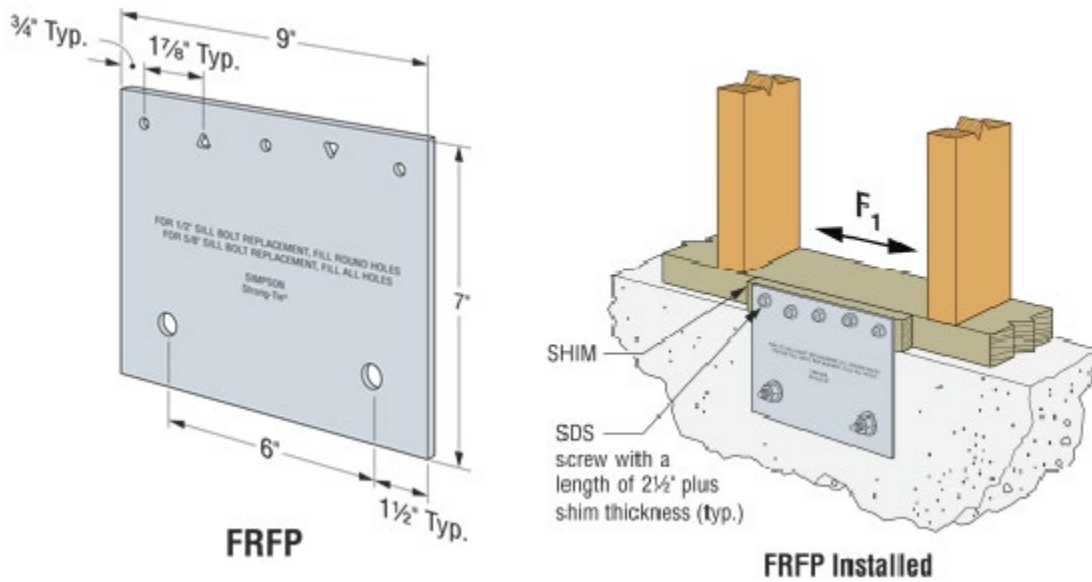

FIGURE 8—FRFP FLAT RETROFIT FOUNDATION PLATE

DIVISION: 06 00 00—WOOD, PLASTICS AND COMPOSITES
Section: 06 05 23—Wood, Plastic, and Composite Fastenings

REPORT HOLDER:

SIMPSON STRONG-TIE COMPANY INC.

EVALUATION SUBJECT:

SIMPSON STRONG-TIE® CONNECTORS ATTACHING WOOD MEMBERS TO CONCRETE CONSTRUCTION

1.0 REPORT PURPOSE AND SCOPE

Purpose:

The purpose of this evaluation report supplement is to indicate that Simpson Strong-Tie® connectors attaching wood members to concrete construction, described in ICC-ES evaluation report [ESR-2616](#), have also been evaluated for compliance with the codes noted below as adopted by the Los Angeles Department of Building and Safety (LADBS).

Applicable code editions:

- 2023 *City of Los Angeles Building Code* (LABC)
- 2023 *City of Los Angeles Residential Code* (LARC)

2.0 CONCLUSIONS

The Simpson Strong-Tie® connectors attaching wood members to concrete construction, described in Sections 2.0 through 7.0 of the evaluation report [ESR-2616](#), comply with the LABC Chapter 23, and the LARC, and are subjected to the conditions of use described in this supplement.

3.0 CONDITIONS OF USE

The Simpson Strong-Tie® connectors attaching wood members to concrete construction, described in this evaluation report supplement, must comply with all of the following conditions:

- All applicable sections in the evaluation report [ESR-2616](#).
- The design, installation, conditions of use and labeling are in accordance with the 2021 *International Building Code*® (IBC) provisions noted in the evaluation report [ESR-2616](#).
- The design, installation and inspection are in accordance with additional requirements of LABC Chapters 16 and 17, as applicable.
- Allowable loads must be reduced when load durations with lower value C_d (than what is in tables) govern.
- Under the LARC, an engineered design in accordance with LARC Section R301.1.3 must be submitted.

This supplement expires concurrently with the evaluation report, reissued February 2024.

DIVISION: 06 00 00—WOOD, PLASTICS AND COMPOSITES
Section: 06 05 23—Wood, Plastic, and Composite Fastenings

REPORT HOLDER:

SIMPSON STRONG-TIE COMPANY INC.

EVALUATION SUBJECT:

SIMPSON STRONG-TIE® CONNECTORS ATTACHING WOOD MEMBERS TO CONCRETE CONSTRUCTION

1.0 REPORT PURPOSE AND SCOPE**Purpose:**

The purpose of this evaluation report supplement is to indicate that the Simpson Strong-Tie® connectors attaching wood members to concrete construction, described in ICC-ES evaluation report ESR-2616, have also been evaluated for compliance with the codes noted below.

Applicable code editions:

- 2023 *Florida Building Code—Building*
- 2023 *Florida Building Code—Residential*

2.0 CONCLUSIONS

The Simpson Strong-Tie® connectors attaching wood members to concrete construction, described in Sections 2.0 through 7.0 of ICC-ES evaluation report ESR-2616, comply with the *Florida Building Code—Building*, and the *Florida Building Code—Residential*. The design requirements must be determined in accordance with the *Florida Building Code—Building* or the *Florida Building Code—Residential*, as applicable. The installation requirements noted in ICC-ES evaluation report ESR-2616 for the 2021 *International Building Code*® meet the requirements of the *Florida Building Code—Building* or the *Florida Building Code—Residential*, as applicable.

Use of the Simpson Strong-Tie® connectors attaching wood members to concrete construction has also been found to be in compliance with the High-Velocity Hurricane Zone provisions of the *Florida Building Code—Building*, and the *Florida Building Code—Residential* with the following condition:

- a. For connections subject to uplift, the connection must be designed for no less than 700 pounds (3114 N).

For products falling under Florida Rule 61G20-3, verification that the report holder's quality assurance program is audited by a quality assurance entity approved by the Florida Building Commission for the type of inspections being conducted is the responsibility of an approved validation entity (or the code official when the report holder does not possess an approval by the Commission).

This supplement expires concurrently with the evaluation report, reissued February 2024.